

SSEN Distribution

CUSTOMER WORKS GUIDE

FOR SERVICE ALTERATION
(LOW VOLTAGE)



Scottish & Southern
Electricity Networks

Powering our
community



WELCOME TO YOUR CUSTOMER WORKS GUIDE

This guide provides information for the steps you may need to take to get ready for your Service Alteration. Read through this guide along with your quote letter and design document. All site specific information will be discussed with your Project Manager. Click on each step to find out more.

WHY NOT PRINT THIS PAGE AND TICK EACH STEP ONCE COMPLETE



PLANNING

STEP 1 - Book us in

Book an appointment with us to move our equipment so that it is ready for your energy supplier to move your meter. See pages 4 - 5 for more information.

STEP 2 - Book your meter move

Book an appointment for your energy supplier to move your meter and meter tails. See pages 6 -7.

STEP 3 - Book an electrician

Book an appointment for your electrician to move and reconnect your internal wiring. See pages 8 - 9.

INTERNAL METER LOCATION

STEP 4 - Drilling external walls

If your new meter position will be internal, you will need to drill a hole so our service cable can be installed to its new position. See pages 10 - 11.

STEP 5A - Buy a meter board

You only need to complete this step if your meter will be internal. See pages 12 -13.

STEP 5B - Fit meter board

You only need to complete this step if your meter will be internal. See pages 14 -15.

EXTERNAL METER LOCATION

STEP 6A - Buy a meter box and a hockey stick

You only need to complete this step if your meter will be external. See pages 16 - 17.

STEP 6B - Fit the meter box and hockey stick

You only need to complete this step if your meter will be external. See pages 18 - 19.

PREPARING YOUR SITE

STEP 7 - Prepare to dig

Read our guidance around preparing to dig safely if you or your contractor will be digging. See pages 20 - 21.

STEP 8A - Onsite digging

If you have chosen for you/your contractor to complete your onsite digging, more information can be found here. See pages 22 - 23.

STEP 8B - Onsite ducting

Buy and install your ducting, for further information click here. See pages 24 - 25.

STEP 9 - Send us your site photos

Once your site is ready for us to start work, send your photos to your project manager. See pages 26 - 27.

STEP 10 - Refilling trenches and joint holes

You or your contractor will need to refill the holes you have dug onsite. See pages 28 - 29.



BOOK US IN

Your project manager will contact you to discuss your job in more detail, including connection dates, next steps and possible site visits.

There are three key stages involved in moving your meter. In the diagram below, the sections shown in yellow highlight the equipment we will move, including service cable and main fuse/cut-out. Each stage is colour-coded to show who is responsible for the work.

Need to contact us?
see page 32

STAGE 1 – SSEN DISTRIBUTION

- 1 Service cable
- 2 Main fuse/cut-out

This is the work we will complete for you. We will move your service cable and main fuse/cut-out.

STAGE 2 – YOUR ENERGY SUPPLIER

- 3 Energy supplier meter tails
- 4 Electricity meter

Your meter and meter tails will need to be moved by your energy supplier. For more information see step 2.

STAGE 3 – YOUR ELECTRICIAN

- 5 Customer meter tails
- 6 Isolator (recommended)
- 7 Consumer unit/fuse box

Your internal electrics will need to be moved and reconnected by a qualified electrician. For more information see step 3.

The numbered labels on the diagram identify exactly which party is responsible for moving each piece of equipment. Your project manager will guide you through every step so you always know what happens next.

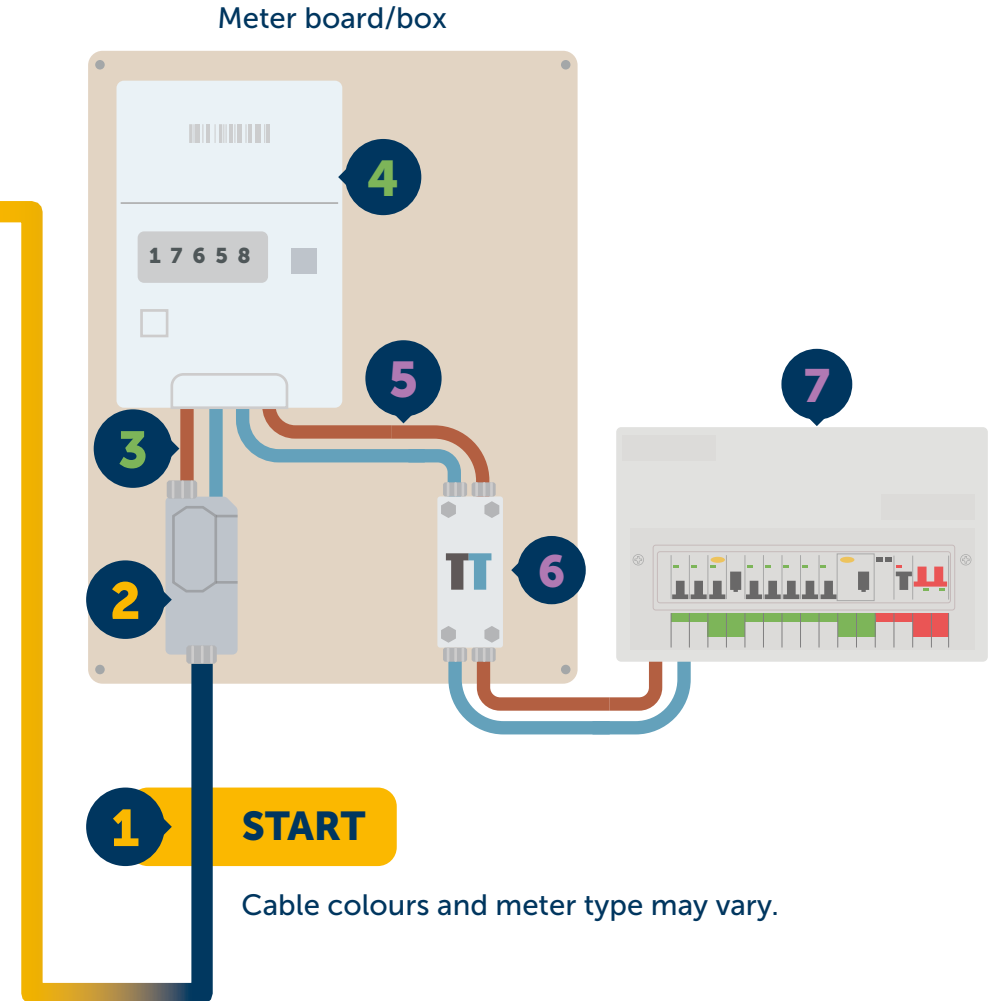



BOOK YOUR METER MOVE

It's time to book an appointment with your energy supplier to move your meter/meter tails.

Your energy supplier is who you pay your electricity bill to. To find out who your supplier is, click below.

szen.co.uk/supplier-search/

STAGE 1 – SSEN DISTRIBUTION

- 1 Service cable
- 2 Main fuse/cut-out

This is the work that we complete for you. We will install and connect your service cable and main fuse/cut-out. For more information, see step 2.

STAGE 2 – YOUR ENERGY SUPPLIER

- 3 Energy supplier meter tails
- 4 Electricity meter

Your meter will need to be installed by your chosen energy supplier.

STAGE 3 – YOUR ELECTRICIAN

- 5 Customer meter tails
- 6 Isolator (recommended)
- 7 Consumer unit/fuse box

You will need to contact a qualified electrician and arrange for them to complete any internal electrical work. For more information, see steps 5a and 5b.

Your appointment with your energy supplier should take place after we've completed our work. Please make sure you book this in advance.

Your energy supplier's appointment should be on the same day to reduce the time your property is without power, but it must be scheduled for the afternoon, once we have moved our equipment. This will help make sure you're not without electricity for any longer than necessary.

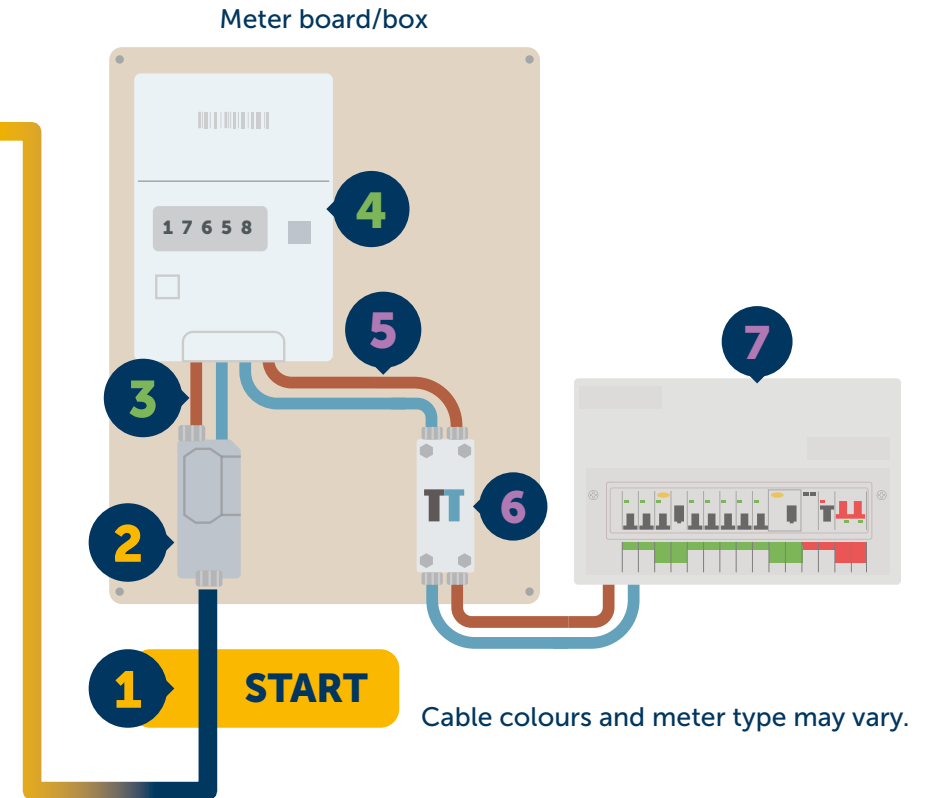



BOOK AN ELECTRICIAN

It's time to book an appointment to move your consumer unit/trip switches and any other internal wiring.

Book an appointment for your electrician to complete your internal wiring as shown in purple on the diagram below. This appointment should be booked in advance, but must take place after we have moved our equipment and your energy supplier has moved your meter. We recommend that your electrician and energy supplier attend site in the afternoon at the same time to complete their work to make sure you have power the same day.

STAGE 1 – SSEN DISTRIBUTION

- 1 Service cable
- 2 Main fuse/cut-out

This is the work we will complete for you. We will move your service cable and main fuse/cut-out. For more information see step 1.

STAGE 2 – YOUR ENERGY SUPPLIER

- 3 Energy supplier meter tails
- 4 Electricity meter

Your meter and meter tails will need to be moved by your energy supplier. For more information see step 2.

STAGE 3 – YOUR ELECTRICIAN

- 5 Customer meter tails
- 6 Isolator (recommended)
- 7 Consumer unit/fuse box

Your internal electrics will need to be moved and reconnected by a qualified electrician to.

THIS CAN INCLUDE THINGS SUCH AS:

- Connect your consumer unit/fuse board.
- Drill external walls (Internal meter only).
- Isolators.
- Residential current device (RCD).
- Fuse switch.
- Prepare meter tails.

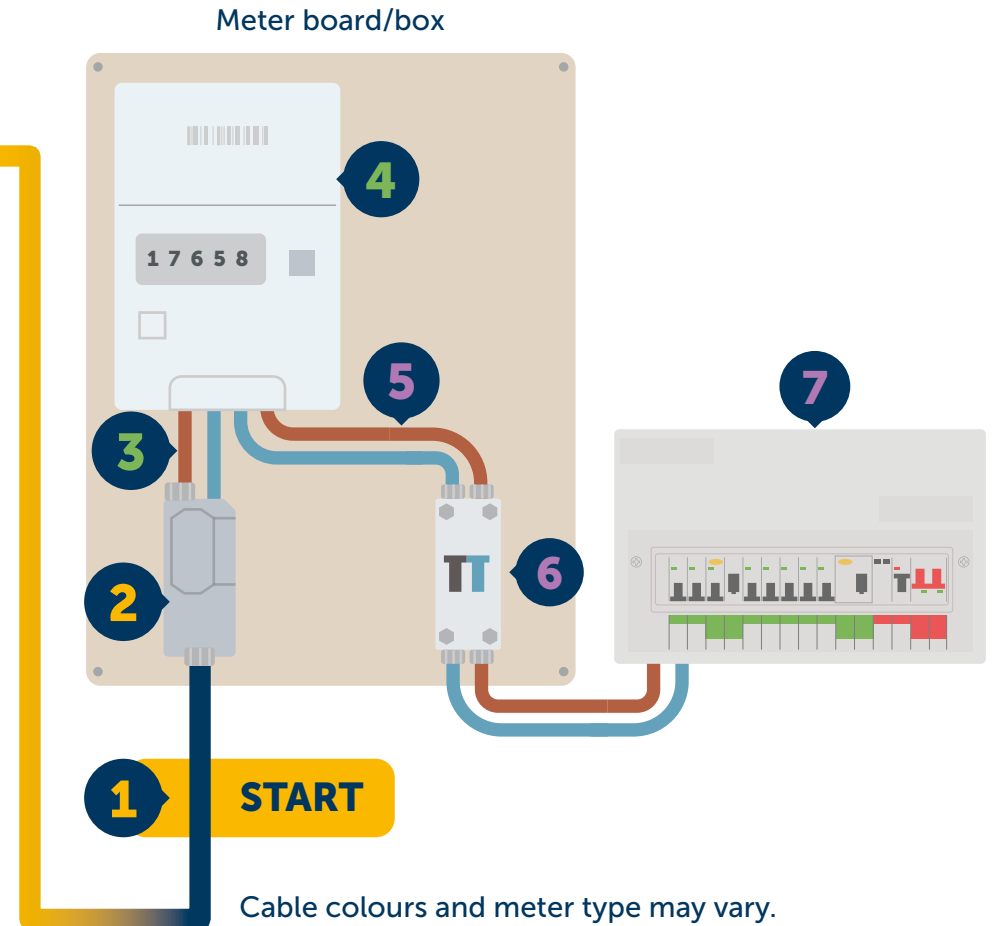



DRILLING WALL(S) INFORMATION

If you are relocating your meter to an internal position within your property, you'll need to make sure that any new ducting and drilled entry points are prepared before our team arrives.

A qualified builder or contractor of your choice can complete this work.

IF YOUR SERVICE CABLE IS UNDERGROUND

The size of the duct will depend on the type of service cable you are having installed. See table below:

TYPE OF SERVICE CABLE	INSIDE DIAMETER OF DUCT
SINGLE PHASE	32mm
SPLIT	100mm
THREE PHASE	100mm

The duct should enter your property using a long-radius bend and finish at floor level. Outside, it must exit the building at a depth of 450 mm (measured to the top of the duct) below the finished ground level as shown in Diagram A on page 11.

To make sure the drilled holes are in the correct place for our service cable to enter your property and stop water from getting in or causing damage to other services drill:

- From the inside of the building to the outside.
- Start drilling above finished floor level at a downwards 45 degree angle.
- The exit point must be 450mm below the finished ground level ready for you to fit the service duct.



DIAGRAM A

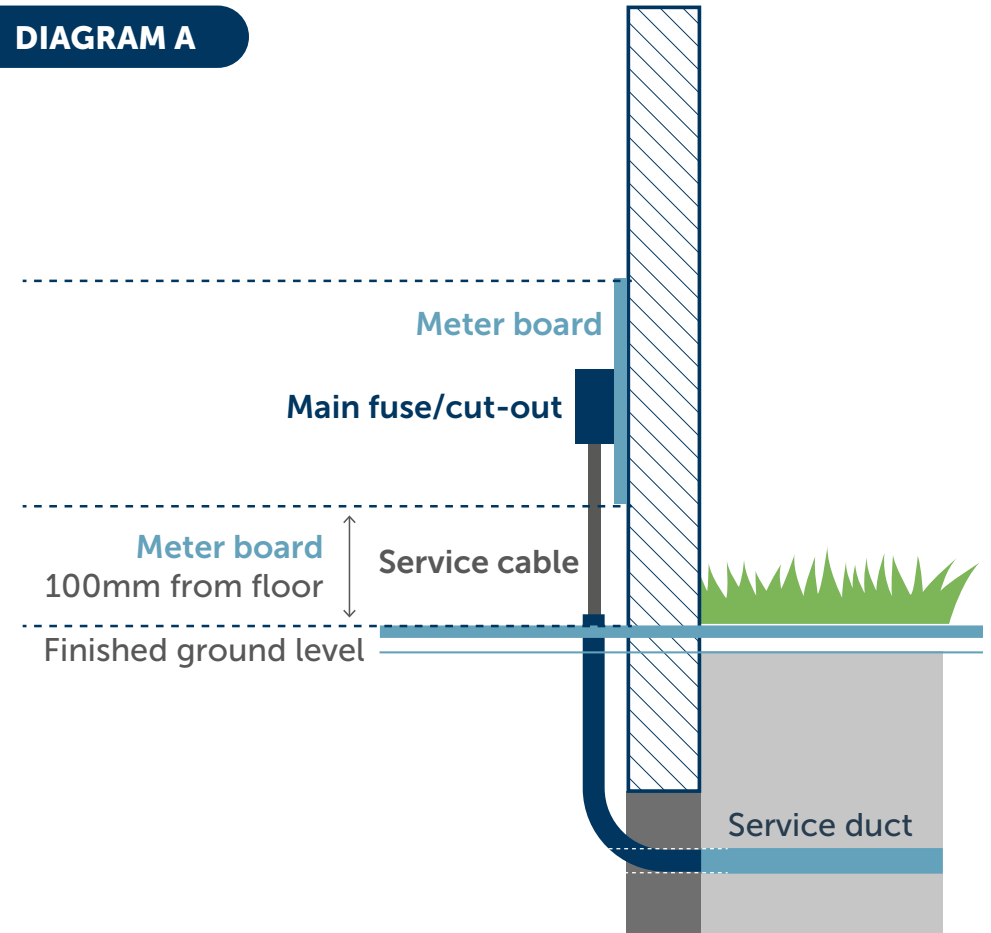

IF YOUR SERVICE CABLE IS OVERHEAD

If your electricity service cable is moving to an alternative overhead position, you'll need to make sure that any drilled entry holes are suitable for the larger service cable. A qualified builder or contractor of your choice can carry out this work.



BUY YOUR METER BOARD – INTERNAL METER ONLY

If you are moving your meter to a new internal location within your property, you'll need to ensure that a suitable meter board is installed at the new position before we can carry out our work. This provides a safe and secure surface for us to mount our equipment and for your electricity supplier to reinstall your meter.

You are responsible for supplying and fitting the appropriate meter board, along with any spacers required, ahead of your planned appointment.

The table below lists the meter board sizes that can be used.

Please check the requirements for the equipment being installed at your new meter location, as this will determine the size of the board you need.

METER BOARD DIMENSIONS	WIDTH	HEIGHT
SINGLE PHASE	300mm	300mm
SPLIT	600mm	450mm
THREE PHASE	600mm	450mm

IMPORTANT

METER BOARDS MUST BE FLAME RETARDANT
These can be purchased from any local hardware store.



METER BOARD

YOU MUST

- Buy your meter board and 4 x meter board spacers.
- Meter board spacers/bushes will be needed to fit the meter board. This will allow the meter board to be fitted securely while creating a gap between the meter board and the wall for air to flow. It also allows for cables to be routed behind the board if required.
- Spacers must be 20mm in length and 20mm in diameter.

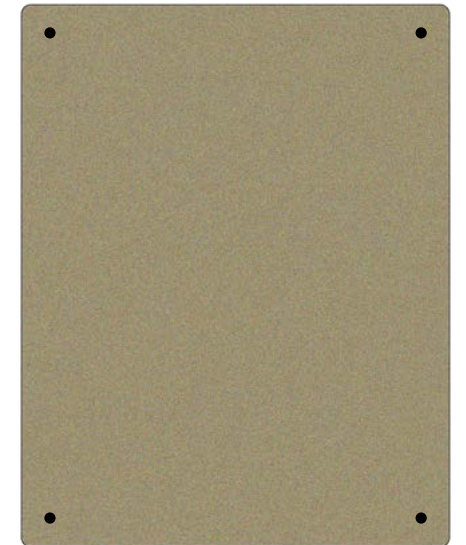
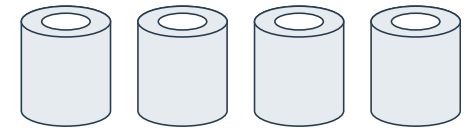



FIT YOUR METER BOARD – INTERNAL METER ONLY

Once you have purchased the appropriate meter board for the new internal meter location, it must be fitted in place before we can install our equipment.

As part of the relocation process, our team will remove the existing equipment from your current meter position. The new meter board should be installed only at the alternative location you requested and agreed to as part of your project.

Please ensure that the position of the newly fitted meter board meets the guidance outlined below so that our equipment can be installed safely and correctly.

INTERNAL CUT-OUT/METER LOCATION

IT MUST BE

- Located on the inside face of an external wall.
- Located to provide adequate separation when situated near gas or water installations.
- The cable duct must be fitted flush to the wall.
- The SSEN meter board must be a minimum of 200mm above ground level, as shown in the diagrams on page 17.
- If going in a timber frame building, it must be on an external wall, on a flame-retardant meter board and not on a plasterboard wall.

IT MUST NOT BE

- In an attic, kitchen, utility room, bedroom, bathroom or basement.
- On the ceiling or under the stairs with less than 2m headroom.
- On a partition stud dry-lined wall, inside the property.

STEP 5B



SINGLE PHASE SUPPLY

Shaded area to be kept clear of obstructions.

All measurements are shown in mm.

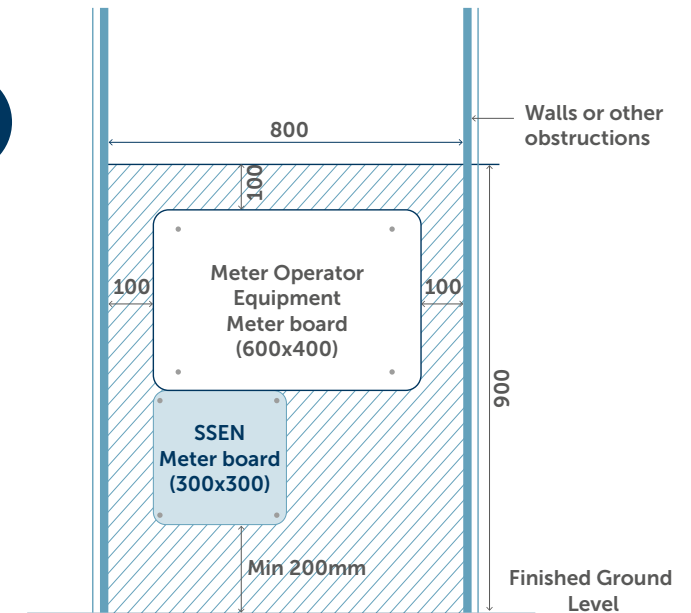

SPLIT/THREE PHASE SUPPLY

Shaded area to be kept clear of obstructions.

All measurements are shown in mm.

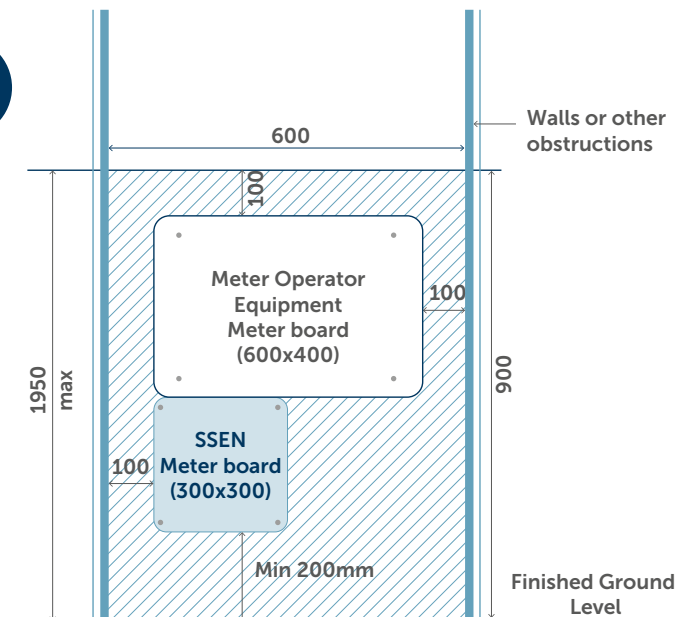



BUY YOUR METER BOX – EXTERNAL METER ONLY

If you are relocating your electricity meter to an external position, you will need to purchase a suitable external electricity meter box and a hockey stick for the new installation.

These must be in place so that we can install our equipment safely and your electricity supplier can fit the meter in its new outdoor location.

Meter boxes can be:

SURFACE MOUNTED

RECESS MOUNTED

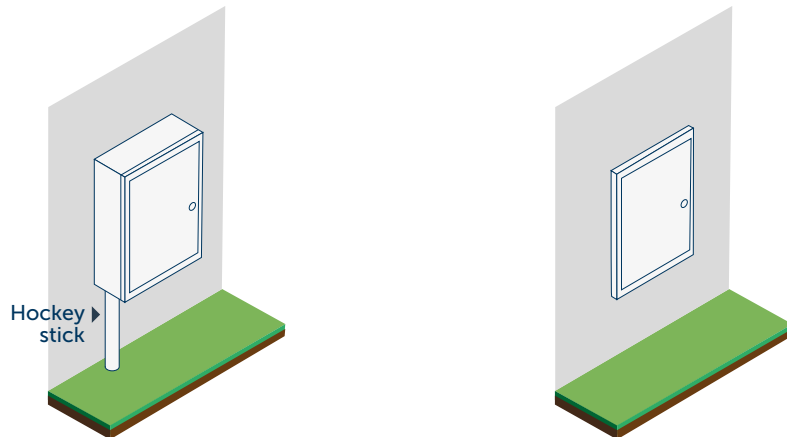

The table below provides guidance on the correct type and size of meter box and hockey stick to purchase, along with suggested suppliers. Ensure that the equipment you choose meets the minimum requirements for the new external meter position. All external meter boxes must include a compliant, flame-retardant backboard that meets current electrical standards.

	HEIGHT	WIDTH	DEPTH	HOCKEY STICK
SINGLE PHASE	560mm	400mm	210mm	40mm
SPLIT/THREE PHASE	750mm	520mm	190mm	50mm

RECESSED TYPE	SUPPLIER		
	TRICEL	MITRAS	
Large recessed	✓	✓	✗
Medium recessed	✓	✓	✗
Cavity cable entry via a hockey stick or polyduct	✓	✓	✗
Cable entry on the face of the wall via hockey stick (medium box only)	✗	✓	✓
SSEN cable on face of wall covered by a cable guard	✓	✓	✓

SURFACE MOUNTED TYPE			
Large surface	✓	✓	✓
Medium surface	✓	✓	✓
Cable entry on the face of the wall via hockey stick (medium box only)	✗	✓	✓
SSEN cable on face of wall covered by a cable guard	✓	✓	✓

= Suitable for Timber Framed Buildings.

When purchasing a meter box, you will require the following minimum internal space:

	HEIGHT	WIDTH
SINGLE PHASE	500mm	300mm
SPLIT/THREE PHASE	600mm	450mm

If you are considering additional isolators or equipment, you will require a larger meter box.

Link for meter box suppliers
meterboxes.co.uk/pages/electric-meter-boxes



FIT YOUR METER BOX AND HOCKEY STICK – EXTERNAL METER ONLY

Once you have purchased the appropriate external meter box and hockey stick for the new meter location, these must be installed before we can fit our equipment.

As part of the meter relocation, our team will remove the existing equipment from your current meter position. The new external meter box should be installed only at the location you requested and agreed to as part of your project.

Please ensure that the position of the new meter box meets the guidance outlined below so that installation can be completed safely and correctly.

EXTERNAL CUT-OUT/METER LOCATION

YOU MUST:

- Supply the meter cabinet and install the hockey stick or cable cover.
- Details of sizes and where to purchase these are on page 18.
- Label your electricity meter box if you have more than one supply going into the building.
- You will need to make a hole in the bottom left-hand side of the meter box. This is where our electricity cable will enter the meter box.

IT MUST NOT BE

- Put your meter in a locked cabinet, bin storage or behind a locked gate.
- Put your meter in the path of a fire exit. There must be 1m clearance.
- Install a recessed meter cabinet into a timber framed property.

UPPER LEVEL METER LOCATIONS

We always connect our cut-out/main fuse at ground level. If your connection is for the first floor or above, your project manager will discuss your options and advise you of the next steps. We will not run our cable in walls, lofts, lift shafts, or other cavities not specifically designed to contain cables.

The diagrams below illustrate how cabinets must be installed to enable safe access.

EXTERNAL SURFACE MOUNTED METER BOX

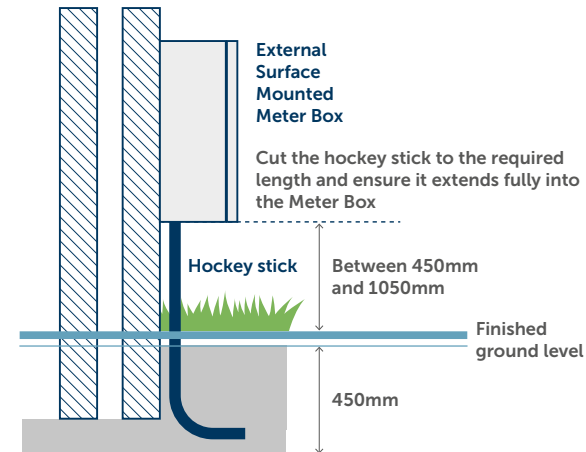

EXTERNAL RECESSED MOUNTED METER BOX

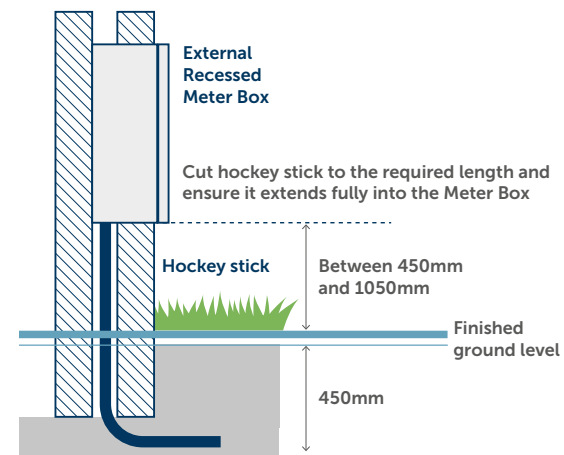



PREPARING TO DIG

Working together safely is our highest priority. Before any digging or site activity begins, your Project Manager will advise you of the planned work area, ensure all safety standards are in place, and confirm compliance with the New Roads and Street Works Act (NRSWA).

They will also support you with permissions, notifications, land rights and any safety arrangements needed for work near underground services, overhead lines or public highways. Although your Project Manager provides this guidance, you **MUST** still complete your own checks to keep yourself and others safe.

1. WORKING UNDERGROUND

PLAN - Before You Dig Follow HSG47 – Avoiding Danger from Underground Services [hse.gov.uk/pubns/priced/hsg47.pdf](https://www.hse.gov.uk/pubns/priced/hsg47.pdf). Obtain up-to-date utility plans via Linesearch BeforeUdig (LSBUD): lsbud.co.uk. Ensure all workers review utility plans before starting. If plans do not match site conditions, contact the relevant utility provider before digging.

SCAN - Before and During Excavation Use a calibrated CAT to scan the full work area before breaking ground. Identify potential service indicators such as meters, covers, ducts, entry points or street furniture. Mark all detected services clearly so all workers understand risk areas. Rescan continuously during excavation, watching for: Warning tape, Ducts or covers, unexpected materials or obstructions.

2. WORKING AT HEIGHT

PLAN - Equipment Safety Near Excavations and Overhead Lines - This applies to all long or extendable equipment, including Scaffolding, Ladders, Poles, and Extendable or telescopic tools. Key rules: Keep all such equipment at least 3 metres from any excavation. Do not work beneath active scaffolding or unstable structures.

SCAN - For Overhead Electricity Cables Follow GS6 – Avoiding Danger from Overhead Power Lines [hse.gov.uk/pubns/gs6.htm](https://www.hse.gov.uk/pubns/gs6.htm). Treat all overhead lines as live unless formally confirmed otherwise. Maintain required exclusion zones. Use goalposts, barriers and signage where overhead hazards exist.

IMPORTANT

YOU MUST - Complete your own checks of safe routes to dig before you start digging.

3. WORKING ON THE PUBLIC HIGHWAY AND NRSWA REQUIREMENTS

Only SSEN, SSEN-approved contractors, or NRSWA-licensed contractors may carry out excavation in the public highway. The New Roads and Street Works Act 1991 require us to notify local councils and other utility companies before installing equipment. If your contractor is completing the excavation, they are responsible for raising the notifications.

SSEN will only submit our notifications after you have accepted your quote and your appointment date is confirmed.

Minimum Notice Periods:

- 3 days** Minor works (planned duration 3 days or less)
- 10 days** Standard works (planned duration 4–10 days)
- 3 months** Major works (requires a temporary traffic order, duration 11+ days)
- 3 months** Road closures.

All approved permits must be available for SSEN teams to check on arrival. Correct barriers and signage must also be in place. If these requirements are not met, we will be unable to carry out the work, and an abortive charge may apply.

4. DIGGING ON LAND THAT DOES NOT BELONG TO YOU

You or your contractor must obtain all required land rights before excavation begins. These may include Planning permissions, Wayleaves, Environmental approvals, and Landowner permissions. For more information, visit [ssen.co.uk/our-services/land-rights](https://www.ssen.co.uk/our-services/land-rights).



ONSITE DIGGING

If you or your contractor are completing the onsite digging and groundwork, this step will give key information on what dimensions you need to dig to and what materials you need to buy.

Your project manager will be able to tell you which of the below applies to you.

JOINT HOLES AND TRENCH SIZES

Joint holes and cable trenches must be dug to the size and depths shown in the diagrams. Depths will be dependent on the ground type.

When digging down to the cable, it's important to carefully dig around the cable and a further 300mm below the bottom of the cable to make sure we have enough room to safely and successfully make the connection.

YOU MUST

- Complete your own checks of safe routes to dig BEFORE you start to dig.
- Place barriers around all holes that have been dug to help prevent anyone from falling in.
- Have a water pump available to remove any water from the holes you have dug.
- Make sure all soil dug out is at least 1 meter away from the joint bay/ trench, so it doesn't fall back in.
- If digging near an electricity or BT pole, leave a 1m space between the pole and the hole you have dug. If your cable is being moved next to or up the pole, please dig the remaining 1m out the day before we are due to arrive.

CABLE TRENCH DEPTHS

Width - 250mm

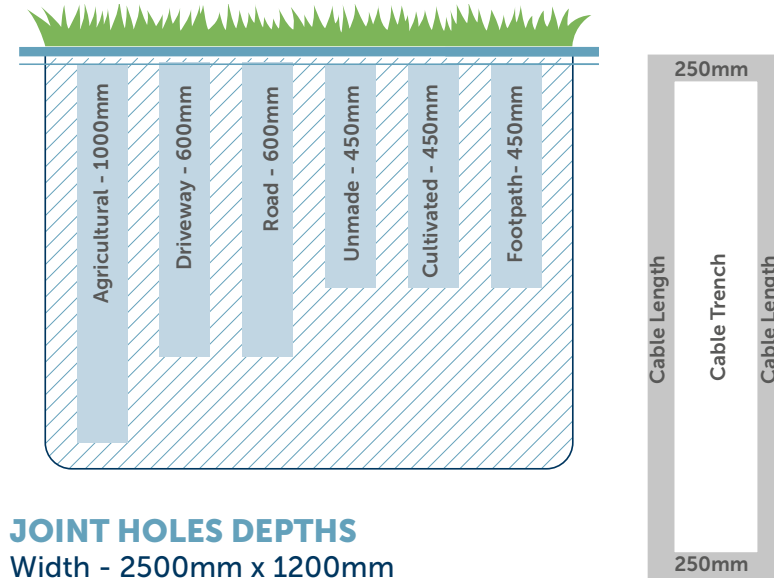

JOINT HOLES DEPTHS

Width - 2500mm x 1200mm

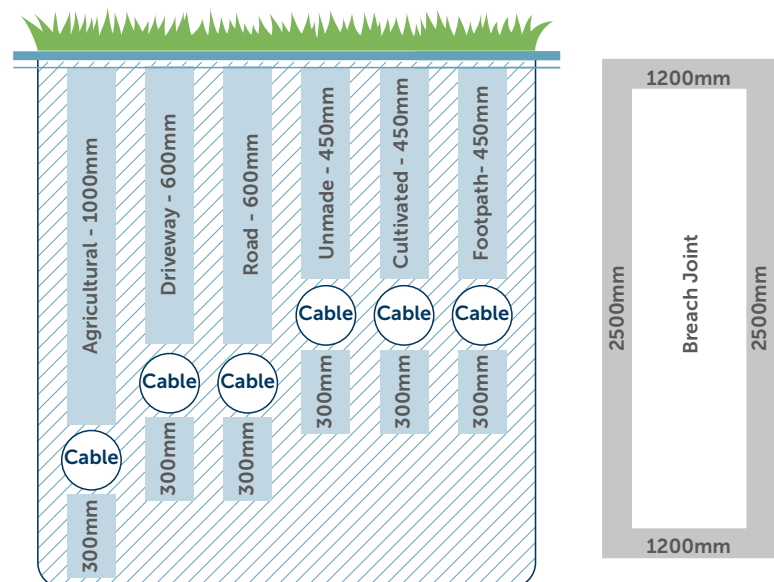



ONSITE DUCTING

If you or your contractor will be completing your own on-site digging and groundwork.

This page will tell you important information such as how to duct the trenches, what material you need to buy, when and how to refill the trenches.

BUYING YOUR DUCTING

Ducting requirements will be discussed with your project manager. Do not buy or install your ducting until you have discussed your site specific needs. Minimum internal diameters of ducting are given in the table below:

CABLE TYPE	MINIMUM INTERNAL DUCT DIAMETER
SINGLE PHASE SERVICE CABLE	32mm
SPLIT/THREE PHASE SERVICE CABLE	100mm
MAIN LOW VOLTAGE CABLE	150mm

YOU MUST

- Buy and install Black electrical ducting manufactured to the ENATS 12-24 standard, minimum class 2.
- Buy and install 6/8mm BT cord/blue nylon cord, laid ducting so that we can pull the cable through.
- Provide the builders' sand to surround the cable or duct by 75mm on all sides. You need to purchase 4 tonnes of sand per 100 meters.
- Mark ducting with unbranded yellow vinyl tape or SSEN branded vinyl tape.

Do not use the drawstring that comes with the ducting, this is not strong enough to pull the cables through. You will be responsible for clearing the ducting if it gets blocked.

The ducting and the BT/Nylon pull cores are available to buy from any builders' merchants.

INSTALLING YOUR DUCTING

You are required to install the ducting from the joint position at the mains cable to the meter box/meter board.

Ducts should be laid straight where possible with a minimum number of bends. Where bends are required, please discuss this with your project manager.

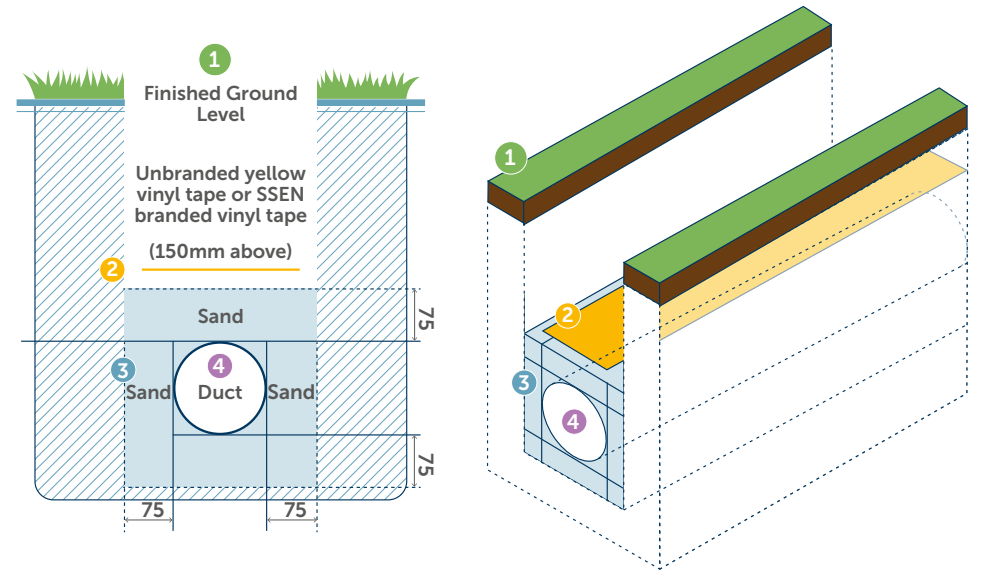

- 1** Finished Ground Level
- 2** Electrical warning tape a minimum of 150mm above duct (unbranded yellow or SSEN-branded)
- 3** Sand - At 75mm of fill to all sides of the laid duct
- 4** Cable joint

ONCE DUCTING IS INSTALLED

We will need to check that the ducting and marker tape have been installed correctly. If you wish to refill your trench before we visit, you can do so. However, please see guidance on step 11 and leave the end of the ducting exposed for us to check it has been installed correctly, including drawstring. If this hasn't been completed correctly, you will need to correct this, which may include you re-digging the hole and could be subject to a cancellation fee. Following cable installation, the ducts should be sealed by you or your contractor.



SEND A PHOTO OF YOUR SITE

Send your Project Manager a photo of the agreed meter location and the ducted entry into the building or meter box/hockey stick.

Please also include photos of your site showing the completed digging and groundwork ready for our arrival.

Requirements may vary depending on your site. Your project manager will discuss what applies to your individual project.

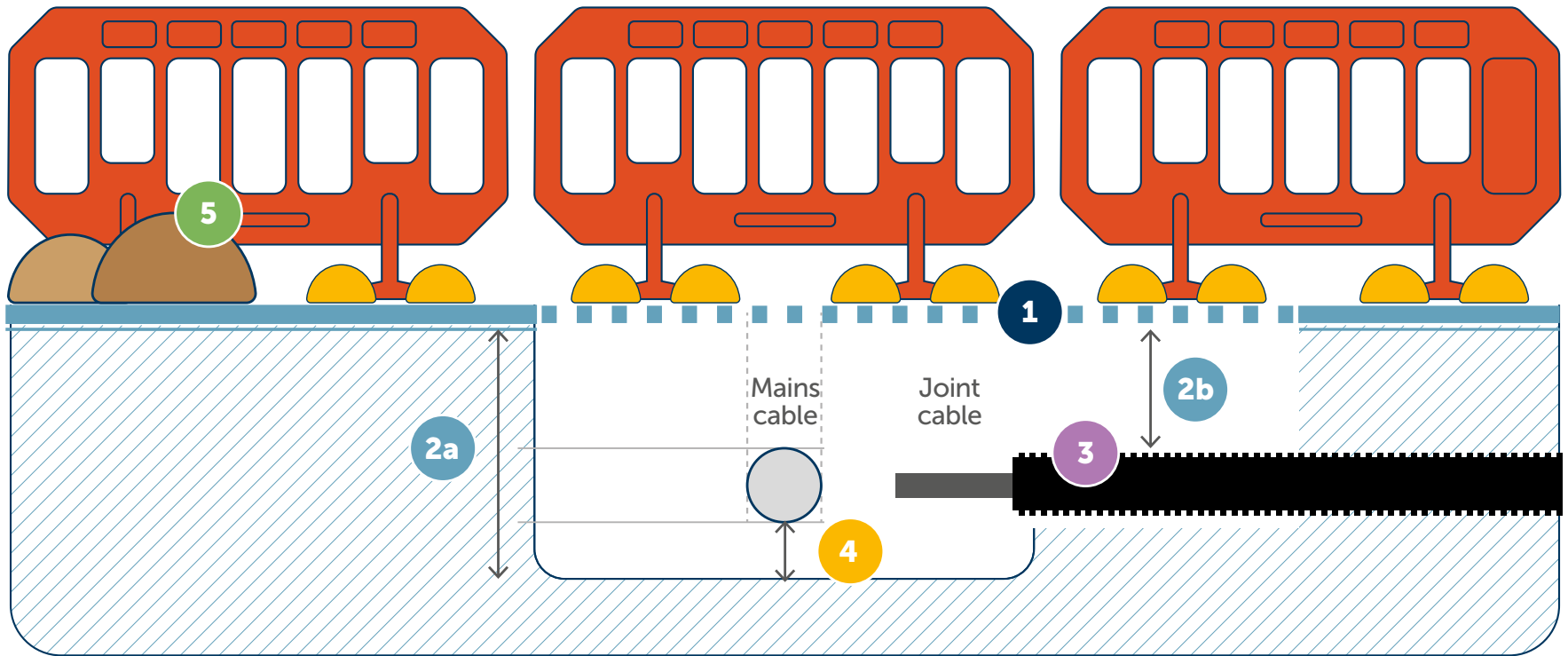

- 1** Joint hole surrounded with barriers and sandbagged.
- 2a** Depths of the Joint Hole will vary as per the diagram dependent on the ground type.
- 2b** Depths of the Cable Trench will vary as per the diagram depending on the ground type.
- 3** Black ducting supplied for us to pull the service cable through.
- 4** 300mm dug out under the mains cable.
- 5** Soil at least 1 metre away from the joint hole/trench.

IMPORTANT

If your site is not ready, we won't be able to complete our work, and a cancellation fee of at least £150 (+VAT) may apply. To avoid this fee, let your project manager know as soon as possible, at least 2 working days' notice before we are due to start work.



REFILLING TRENCHES AND JOINT HOLES

You or your contractor will be responsible for refilling the holes you dug onsite.

Here is some guidance on preparing and refilling your trench/joint hole.

PREPARING TO REFILL

Following cable installation, the ducts must be sealed by you or your contractor before you start to refill your trench/joint hole.

YOU MUST

- Provide the building sand to surround the cable or duct by 75mm on all sides. You need to purchase 4 tonnes of sand per 100 meters.

REFILLING TRENCHES WITH DUCTING

When ducting is used and you wish to refill your trench before we visit, you can do so as shown in the diagram on page 31. However, please leave the end of the ducting exposed, for us to check it has been installed correctly, including the drawstring.

If this hasn't been completed correctly you will need to correct this which may include you re-digging the hole and could be subject to a cancellation fee.

REFILLING TRENCHES WITH NO DUCTING

When ducting is not used, after we (SSEN) have laid the cable cover with sand to the dimensions specified, install the marker tape and refill to ground level.

REFILLING THE JOINT HOLE

You should wait at least 3 hours before refilling the joint hole. We will cover the laid mains cable with the sand you have brought before leaving the site.

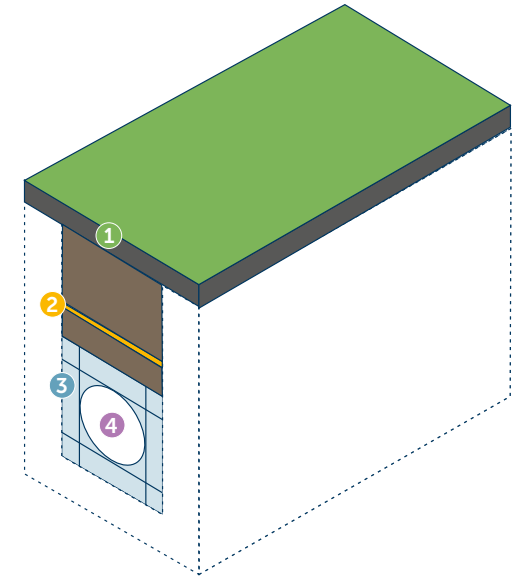
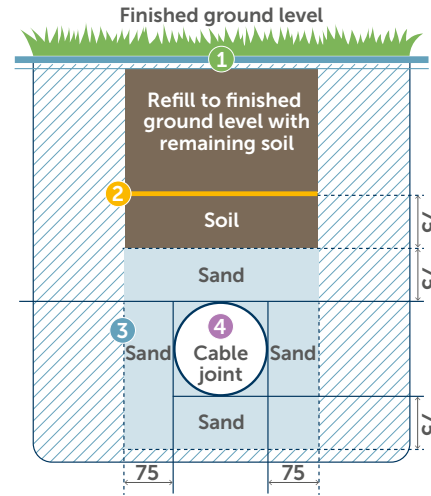

- 1** Finished Ground Level
- 2** Unbranded yellow vinyl tape or SSEN branded vinyl tap - At least 150mm above the laid duct
- 3** Sand - At 75mm of fill to all sides of the laid duct
- 4** Cable joint

REFILLING PUBLIC FOOTWAYS AND HIGHWAYS

All reinstatement in public footways and highways must comply with the New Roads and Street Works Act 1991, 'Specification for the Reinstatement of Openings in Highways' and National Joint Utilities Group:

England:

Specification for Reinstatement of the Opening in Highways: assets.publishing.service.gov.uk/media/6839b437210698b3364e86f7/reinstatement-works-after-doing-streetworks.pdf

Scotland:

Specification for the Reinstatement of Openings in Roads: transport.gov.scot/media/44955/sror-specification-for-the-reinstatement-of-openings-in-roads-2019.pdf



NOTES

A large, empty light blue rectangular area intended for taking notes on page 30.



A large, empty light blue rectangular area intended for taking notes on page 31.



WHO CAN I ASK FOR HELP?

For any questions or to request further information about your new connection, please speak with your Project Manager or:



Call us on
0800 048 3516



Visit our website
ssen.co.uk/movingyourmeter



Email us
connections@ssen.co.uk

HAVE YOU HEARD ABOUT OUR PRIORITY SERVICES?

Priority Services is a free service for customers who may need extra help during a power cut or have specific communication needs.

This includes priority updates during a power cut, proactive 24-hour alerts when we know the power is off and providing information in different languages.



Call us on
0800 294 3259



Textphone
0800 316 5457



More information
ssen.co.uk/psr

