



**Southern Electric Power Distribution plc**

**Use of System Charging Statement for its**

**Embedded Distribution Networks**

**NOTICE OF CHARGES**

**Effective from 1<sup>st</sup> April 2027**

**Version 1.1**

**This statement is in a form to be  
approved by the Gas and Electricity  
Markets Authority.**

# Version Control

Version	Date	Description of version and any changes made
V 1.0	31/01/2026	SEPD EDN DUoS Charges Final April 2027 (LC14 format) _B & _E charges not yet included as Host DNO (NGED) has until 27-02-26 to publish
V 1.1	March 2026	Charges added for _B & _E (NGED areas)

**A change-marked version of this statement can be provided upon request.**

# Contents

- 1. Introduction..... 7
  - Validity period..... 7
  - Contact details ..... 8
- 2. Charge Application and Definitions..... 9
  - Supercustomer/Aggregated Charges..... 10
  - Site-Specific Billing and Payment ..... 10
  - Site-Specific Billed Charges ..... 10
  - Components of Charges..... 11
  - Residual Charging Bands..... 11
  - Time Periods ..... 11
  - Application of Capacity Charges ..... 11
  - Chargeable Capacity ..... 11
  - Exceeded Capacity ..... 12
  - Demand Exceeded Capacity..... 12
  - Generation Exceeded Capacity ..... 12
  - Standby Capacity for Additional Security on Site ..... 12
  - Minimum Capacity Levels ..... 12
  - Application of charges for reactive power..... 12
  - Demand Chargeable Reactive Power..... 13
  - Generation Chargeable Reactive Power ..... 13
  - Allocation of Charges ..... 13
  - Provision of billing data ..... 15
  - Licensed Distributor Network Operator charges ..... 15
  - Licence exempt distribution networks ..... 15
  - Full settlement metering ..... 15
  - Difference metering..... 16
  - Shared metering ..... 16
  - Gross settlement..... 16
- 3. Schedule of Charges for use of our Embedded Networks..... 17
- 4. Schedule of Line Loss Factors ..... 18
  - Role of Line Loss Factors in the Supply of Electricity ..... 18
  - Calculation of Line Loss Factors ..... 18
  - Publication of Line Loss Factor tables..... 18
- 5. Notes for EHV Properties ..... 20
  - Charges for EHV Properties ..... 20
  - Charges for Amended EHV Properties ..... 20
  - Demand Side Management ..... 20
- 6. Electricity Distribution Rebates ..... 21
- 7. Accounting and Administration Services..... 22
- 8. Charges for electrical plant provided ancillary to the grant of Use of System ..... 23
- 9. Schedule of fixed adders to recover Supplier of Last Resort and Eligible Bad Debt pass-through costs ..... 24
  - Supplier of Last Resort ..... 24
  - Eligible Bad Debt ..... 24
  - Tables of Fixed Adders ..... 24
- 10. Non-Final Demand Sites ..... 25
- 11. Back-up Connections ..... 26
- Appendix 1 – Glossary..... 27

Appendix 2 - Guidance notes .....	34
Background .....	34
Meter point administration .....	34
Your charges .....	35
Reducing your charges.....	35
Reactive power and reactive power charges.....	35
Site-specific charges.....	36
Additional Notes .....	38
Appendix 3 – Non-Final Demand Site Certificate.....	39
Annex 1 - Schedule of Charges for use of the Distribution System by LV and HV Properties in “Eastern Power Networks Area (GSP Group _A)” .....	40
Annex 1 - Schedule of Charges for use of the Distribution System by LV and HV Properties in “NGED East Midlands Area (GSP Group _B)” .....	43
Annex 1 - Schedule of Charges for use of the Distribution System by LV and HV Properties in “London Power Networks Area (GSP Group _C)” .....	46
Annex 1 - Schedule of Charges for use of the Distribution System by LV and HV Properties in “SP Manweb Area (GSP Group _D)” .....	50
Annex 1 - Schedule of Charges for use of the Distribution System by LV and HV Properties in “NGED West Midlands Area (GSP Group _E)” .....	53
Annex 1 - Schedule of Charges for use of the Distribution System by LV and HV Properties in “Northern Powergrid (Northeast) Area (GSP Group _F)” .....	56
Annex 1 - Schedule of Charges for use of the Distribution System by LV and HV Properties in “SP Electricity North West Area (GSP Group _G)” .....	60
Annex 1 - Schedule of Charges for use of the Distribution System by LV and HV Properties in “South Eastern Power Networks Area (GSP Group _J)” .....	64
Annex 1 - Schedule of Charges for use of the Distribution System by LV and HV Properties in “NGED South Wales Area (GSP Group _K)” .....	67
Annex 1 - Schedule of Charges for use of the Distribution System by LV and HV Properties in “NGED South West Area (GSP Group _L)” .....	70
Annex 1 - Schedule of Charges for use of the Distribution System by LV and HV Properties in “Northern Powergrid (Yorkshire) Area (GSP Group _M)” .....	73
Annex 2 - Schedule of Charges for use of the Distribution System by EHV Properties (including LDNOs with EHV Properties/end-users) in “Eastern Power Networks Area (GSP Group _A)” .....	76
Annex 2 - Schedule of Charges for use of the Distribution System by EHV Properties (including LDNOs with EHV Properties/end-users) in “NGED East Midlands Area (GSP Group _B)” .....	77
Annex 2 - Schedule of Charges for use of the Distribution System by EHV Properties (including LDNOs with EHV Properties/end-users) in “London Power Networks Area (GSP Group _C)” .....	78
Annex 2 - Schedule of Charges for use of the Distribution System by EHV Properties (including LDNOs with EHV Properties/end-users) in “SP Manweb Area (GSP Group _D)” .....	79
Annex 2 - Schedule of Charges for use of the Distribution System by EHV Properties (including LDNOs with EHV Properties/end-users) in “NGED West Midlands Area (GSP Group _E)” .....	80
Annex 2 - Schedule of Charges for use of the Distribution System by EHV Properties (including LDNOs with EHV Properties/end-users) in “Northern Powergrid (Northeast) Area (GSP Group _F)” .....	81
Annex 2 - Schedule of Charges for use of the Distribution System by EHV Properties (including LDNOs with EHV Properties/end-users) in “SP Electricity North West Area (GSP Group _G)” .....	82
Annex 2 - Schedule of Charges for use of the Distribution System by EHV Properties (including LDNOs with EHV Properties/end-users) “South Eastern Power Networks Area (GSP Group _J)” .....	83

Annex 2 - Schedule of Charges for use of the Distribution System by EHV Properties (including LDNOs with EHV Properties/end-users) in “NGED South Wales Area (GSP Group _K)” .....	84
Annex 2 - Schedule of Charges for use of the Distribution System by EHV Properties (including LDNOs with EHV Properties/end-users) in “NGED South West Area (GSP Group _L)” .....	85
Annex 2 - Schedule of Charges for use of the Distribution System by EHV Properties (including LDNOs with EHV Properties/end-users) in “Northern Powergrid (Yorkshire) Area (GSP Group _M)” .....	86
Annex 3 - Schedule of Charges for use of the Distribution System to Preserved/Additional LLFC Classes in E&W ....	87
Annex 4 - Charges applied to LDNOs with HV/LV end users in “Eastern Power Networks Area (GSP Group _A)” ....	88
Annex 4 - Charges applied to LDNOs with HV/LV end users in “NGED East Midlands Area (GSP Group _B)” ....	95
Annex 4 - Charges applied to LDNOs with HV/LV end users in “London Power Networks Area (GSP Group _C)” ....	102
Annex 4 - Charges applied to LDNOs with HV/LV end users in “SP Manweb Area (GSP Group _D)” .....	109
Annex 4 - Charges applied to LDNOs with HV/LV end users in “NGED West Midlands Area (GSP Group _E)” .....	116
Annex 4 - Charges applied to LDNOs with HV/LV end users in “Northern Powergrid (Northeast) Area (GSP Group _F)” .....	123
Annex 4 - Charges applied to LDNOs with HV/LV end users in “SP Electricity North West Area (GSP Group _G)” ....	130
Annex 4 - Charges applied to LDNOs with HV/LV end users in “South Eastern Power Networks Area (GSP Group _J)” .....	137
Annex 4 - Charges applied to LDNOs with HV/LV end users in “NGED South Wales Area (GSP Group _K)” ....	144
Annex 4 - Charges applied to LDNOs with HV/LV end users in “NGED South West Area (GSP Group _L)” .....	151
Annex 4 - Charges applied to LDNOs with HV/LV end users in “Northern Powergrid (Yorkshire) Area (GSP Group _M)” .....	158
Annex 5 – Schedule of Line Loss Factors in “Eastern Power Networks Area (GSP Group _A)” .....	165
LLF time periods: .....	165
Annex 5 – Schedule of Line Loss Factors in “NGED East Midlands Area (GSP Group _B)” .....	166
LLF time periods: .....	166
Annex 5 – Schedule of Line Loss Factors in “London Power Networks Area (GSP Group _C)” .....	167
LLF time periods: .....	167
Annex 5 – Schedule of Line Loss Factors in “SP Manweb Area (GSP Group _D)” .....	168
LLF time periods: .....	168
Annex 5 – Schedule of Line Loss Factors in “NGED West Midlands Area (GSP Group _E)” .....	169
LLF time periods: .....	169
Annex 5 – Schedule of Line Loss Factors in “Northern Powergrid (Northeast) Area (GSP Group _F)” .....	170
LLF time periods: .....	170
Annex 5 – Schedule of Line Loss Factors in “Northern Powergrid (Northeast) Area (GSP Group _F)” .....	171
LLF time periods: .....	171
Annex 5 – Schedule of Line Loss Factors in “SP Electricity North West Area (GSP Group _G)” .....	172
LLF time periods: .....	172
Annex 5 – Schedule of Line Loss Factors in “South Eastern Power Networks Area (GSP Group _J)” .....	173
LLF time periods: .....	173

Annex 5 – Schedule of Line Loss Factors in “NGED South Wales Area (GSP Group _K)” .....	174
LLF time periods: .....	174
Annex 5 – Schedule of Line Loss Factors in “NGED South West Area (GSP Group _L)” .....	175
LLF time periods: .....	175
Annex 5 – Schedule of Line Loss Factors in “Northern Powergrid (Yorkshire) Area (GSP Group _M)” .....	176
Annex 6 – Charges for New or Amended EHV Properties in “Eastern Power Networks Area (GSP Group _A)” ....	177
Annex 6 – Charges for New or Amended EHV Properties in “NGED East Midlands Area (GSP Group _B)” .....	178
Annex 6 – Charges for New or Amended EHV Properties in “London Power Networks Area (GSP Group _C)” ....	179
Annex 6 – Charges for New or Amended EHV Properties in “SP Manweb Area (GSP Group _D)” .....	180
Annex 6 – Charges for New or Amended EHV Properties in “NGED West Midlands Area (GSP Group _E)” ....	181
Annex 6 – Charges for New or Amended EHV Properties in “Northern Powergrid (Northeast) Area (GSP Group _F)” .....	182
Annex 6 – Charges for New or Amended EHV Properties in “SP Electricity North West Area (GSP Group _G)” ....	183
Annex 6 – Charges for New or Amended EHV Properties in “South Eastern Power Networks Area (GSP Group _J)” .....	184
Annex 6 – Charges for New or Amended EHV Properties in “NGED South Wales Area (GSP Group _K)” .....	185
Annex 6 – Charges for New or Amended EHV Properties in “NGED South West Area (GSP Group _L)” .....	186
Annex 6 – Charges for New or Amended EHV Properties in “Northern Powergrid (Yorkshire) Area (GSP Group _M)” .....	187
Annex 7 – Supplier of last Resort and Eligible Bad Debt Pass-Through Costs in “Eastern Power Networks Area (GSP Group _A)” .....	188
Annex 7 – Supplier of last Resort and Eligible Bad Debt Pass-Through Costs in “NGED East Midlands Area (GSP Group _B)” .....	194
Annex 7 – Supplier of last Resort and Eligible Bad Debt Pass-Through Costs in “London Power Networks Area (GSP Group _C)” .....	200
Annex 7 – Supplier of last Resort and Eligible Bad Debt Pass-Through Costs in “SP Manweb Area (GSP Group _D)” .....	206
Annex 7 – Supplier of last Resort and Eligible Bad Debt Pass-Through Costs in “NGED West Midlands Area (GSP Group _E)” .....	212
Annex 7 – Supplier of last Resort and Eligible Bad Debt Pass-Through Costs in “Northern Powergrid (Northeast) Area (GSP Group _F)” .....	218
Annex 7 – Supplier of last Resort and Eligible Bad Debt Pass-Through Costs in “SP Electricity North West Area (GSP Group _G)” .....	225
Annex 7 – Supplier of last Resort and Eligible Bad Debt Pass-Through Costs in “South Eastern Power Networks Area (GSP Group _J)” .....	231
Annex 7 – Supplier of last Resort and Eligible Bad Debt Pass-Through Costs in “NGED South Wales Area (GSP Group _K)” .....	237
Annex 7 – Supplier of last Resort and Eligible Bad Debt Pass-Through Costs in “NGED South West Area (GSP Group _L)” .....	243
Annex 7 – Supplier of last Resort and Eligible Bad Debt Pass-Through Costs in “Northern Powergrid (Yorkshire) Area (GSP Group _M)” .....	249

# 1. Introduction

- 1.1 This statement tells you about our charges and the reasons behind them. It has been prepared consistent with Standard Licence Condition 14 of our Electricity Distribution Licence. The main purpose of this statement is to provide our schedule of charges<sup>1</sup> for the use of our Embedded Networks and to provide the schedule of Line Loss Factors<sup>2</sup> that should be applied in Settlement to account for distribution losses. We have also included guidance notes in Appendix 2 to help improve your understanding of the charges we apply.
- 1.2 This statement has been prepared in order to discharge Southern Electric Power Distribution plc's ("SEPD") obligation under Standard Licence Condition 14 of our Electricity Distribution Licence. It contains information on our charges and charging principles for use of our Embedded Networks. It also contains information on our Line Loss Factors. To comply with the terms of Clause 19.1 of the DCUSA, this Statement will be provided to Users (as defined in the DCUSA) not later than 20 days prior to implementation of the charges set out in this Statement.
- 1.3 Within this statement we use terms such as 'Users' and 'Customers' as well as other terms which are identified with initial capitalisation. These terms are defined in the Glossary.
- 1.4 This statement reflects the changes which have been introduced as a result of Market Wide Half Hourly Settlement (MHHS<sup>3</sup>). Although the existing arrangements will continue to apply for Non-Migrated MPANs, the MHHS arrangements will be effective for any MPAN that has Migrated, any differences in treatment are highlighted throughout the document.
- 1.5 We operate Embedded Networks in all other DNO areas in England & Wales (GSP Group ID: \_A, \_B, \_C, \_D, \_E, \_F, \_G, \_J, \_K, \_L & \_M). The charges for these Embedded Networks are provided in this statement.
- 1.6 The charges applicable to Low Voltage (LV) and High Voltage (HV) Properties and Extra-High Voltage (EHV) Properties in this statement have been set in accordance with the methodology described in SEPD's Use of System Charging Methodology for its Embedded Distribution Networks. The application of charges to a premise can be referenced using the Line Loss Factor Class (LLFC) contained in the charge tables.
- 1.7 Separate charges are calculated depending on the characteristics of the connection and whether the use of the Embedded Networks is for demand or generation purposes. Where a generation connection is seen to support the Distribution System the charges will be negative and the Supplier will receive credits for exported energy.
- 1.8 The application of charges to premises can usually be referenced using the Line Loss Factor Class (LLFC)/DUoS Tariff ID contained in the charge tables. Further information on how to identify and calculate the charge that will apply for your premises is provided in the guidance notes in Appendix 2.
- 1.9 All charges in this statement are shown **exclusive** of VAT. Invoices will include VAT at the applicable rate.
- 1.10 The annexes that form part of this statement are also available in spreadsheet format. This spreadsheet contains supplementary information used for charging purposes but which is not required to be provided in accordance with Standard Licence Condition 14. This spreadsheet can be downloaded from our website [www.ssen.co.uk](http://www.ssen.co.uk).

## Validity period

- 1.11 This charging statement is valid for services provided from the effective date stated on the front of the statement and remains valid until updated by a revised version or superseded by a statement with a later effective date.

---

<sup>1</sup> Charges can be positive or negative.

<sup>2</sup> Known as adjustment factors in the Distribution Licence and commonly referred to as Loss Adjustment Factors. The schedule of Line Loss Factors will be provided in a revised statement shortly after the Line Loss Factors for the relevant year have been successfully audited by Elexon.

<sup>3</sup> Information relating to the Market wide HH Settlement Programme available from [Home - MHHS Programme](#)

- 1.12 When using this charging statement care should be taken to ensure that the relevant statement or statements covering the period that is of interest are used.
- 1.13 Notice of any revision to the statement will be provided to Users of our Embedded Networks (with the exception of updates to Annex 6; New or Amended EHV Sites which will be published as an addendum). The latest statements can be downloaded from [www.ssen.co.uk](http://www.ssen.co.uk).

### Contact details

- 1.14 If you have any questions about this statement please contact us at the address shown below:

Distribution Pricing Team  
Southern Electric Power Distribution plc  
Inveralmond House  
200 Dunkeld Road  
Perth  
PH1 3AQ  
Email: [DistributionPricingTeam@sse.com](mailto:DistributionPricingTeam@sse.com)

- 1.15 All enquiries regarding Connection Agreements, changes to Maximum Capacities, and certification of Non-Final Demand sites should be addressed to:

Email: [authorised.capacity@sse.com](mailto:authorised.capacity@sse.com)

Post:  
Authorised Capacity  
Scottish and Southern Electricity Networks  
Daneshill Depot  
Faraday Road  
Basingstoke  
RG24 8QQ

- 1.16 For all other queries please contact our general enquiries telephone number: 0800 048 3516.

## 2. Charge Application and Definitions

2.1 The following section details how the charges in this statement are applied and billed to Users of our Embedded Networks.

### The Supercustomer/Aggregated and site-specific billing approaches

2.2 We utilise two billing approaches depending on the type of metering data received:

- (a) The 'Supercustomer/Aggregated' approach for Customers for whom we receive aggregated consumption data through Settlement; and
- (b) The 'Site-specific' approach for Customers for whom we receive site-specific consumption data through Settlement.

2.3 We receive aggregated consumption data through Settlement for:

#### Non-Migrated MPANS:

- (a) Domestic and non-domestic Customers for whom Non-Half Hourly (NHH) metering data is used in Settlement (i.e. Customers with MPANs which are registered to Measurement Class A);
- (b) Customers which are unmetered and are not settled as pseudo Half Hourly (HH) metered (i.e. Customers with MPANs which are registered to Measurement Class B);
- (c) Domestic Customers for whom HH metering data is used in Settlement (i.e. Customers with MPANs which are registered to Measurement Class F); and
- (d) Non-domestic Customers for whom HH metering data is used in Settlement and which have whole current (WC) metering (i.e. Customers with MPANs which are registered to Measurement Class G).

#### Migrated MPANS:

- (e) All Customers who have a Connection Type that indicates a Whole Current connection, i.e. with Connection Type 'W'.

2.4 We receive site specific consumption data through Settlement for:

#### Non-Migrated MPANS:

- (a) Customers for whom HH metering data is used in Settlement and which have current transformer (CT) metering (i.e. Customers with MPANs which are registered to measurement class C or E); and
- (b) Customers which are unmetered and settled as pseudo HH metered (i.e. Customers with MPANs which are registered to measurement class D).

#### Migrated MPANS:

- (c) All Customers who have a Connection Type of 'L' Low Voltage, 'H' High Voltage, 'E' Extra-High Voltage or 'U' Unmetered.

### Supercustomer/Aggregated Billing and Payment

2.5 The Supercustomer/Aggregated approach makes use of aggregated data obtained from Suppliers using the 'Aggregated Distribution Use of System (DUoS) Report' data flow for Non-Migrated MPANs, and the 'LDSO report for DUoS – aggregated data' message or the 'Embedded Network report for DUoS – aggregated data' message for Migrated MPANs.

2.6 Invoices are calculated on a periodic basis and sent to each User for whom we transport electricity through our Embedded Networks. Invoices are reconciled, over a period of approximately 14 months to reflect later and more accurate consumption figures, this will reduce to 4 months following MHHS implementation.

2.7 The charges are applied on the basis of the LLFC/DUoS Tariff ID assigned to the MPAN, and the units consumed within the time periods specified in Annex 1. All LLFCs/DUoS Tariff IDs are assigned at our sole discretion, based on the tariff application rules set out in the appropriate charging methodology or elsewhere in this statement. Please refer to the section 'Allocation of Charges' if you believe the allocated LLFC/DUoS Tariff ID or tariff is incorrect.

## **Supercustomer/Aggregated Charges**

- 2.8 Supercustomer/Aggregated charges are generally billed through the following components:
- a fixed charge, pence/MPAN/day; there will only be one fixed charge applied to each MPAN; and
  - unit charges, pence/kilowatt-hour (kWh); three unit charges will apply depending on the time of day and the type of tariff for which the MPAN is registered.
- 2.9 Users who wish to supply electricity to Customers for whom we receive aggregated data through Settlement (see paragraph 2.3) will be allocated the relevant charge structure set out in Annex 1.
- 2.10 Identification of the appropriate charge can be made by cross reference to the LLFC/DUoS Tariff ID.
- 2.11 For Non-Migrated MPANs the Valid Settlement Profile Class (PC) /Standard Settlement Class (SSC) / Meter Timeswitch Code (MTC) combinations for LLFCs where the Metering System is Measurement Class A or B are detailed in Market Domain Data (MDD). For Migrated MPANs the appropriate reference data is contained in Industry Standing Data (ISD).
- 2.12 Where an MPAN has an invalid settlement combination, the 'Domestic Aggregated with Residual' fixed and unit charges will be applied as default until the invalid combination is corrected. Where there are multiple SSC/TPR combinations for Non-Migrated MPANs, the default 'Domestic Aggregated with Residual' fixed and unit charges will be applied for each invalid SSC/TPR combination.
- 2.13 The 'Domestic Aggregated (related MPAN)' and 'Non-Domestic Aggregated (related MPAN)' charges are supplementary to their respective primary MPAN charge.

## **Site-Specific Billing and Payment**

- 2.14 The site-specific billing and payment approach makes use of HH metering data at premises level received through Settlement.
- 2.15 Invoices are calculated on a periodic basis and sent to each User for whom we transport electricity through our Embedded Networks. Where an account is based on estimated data, the account shall be subject to any adjustment that may be necessary following the receipt of actual data from the User.
- 2.16 The charges are applied on the basis of the LLFCs/DUoS Tariff IDs assigned to the MPAN or MSID for Central Volume Allocation (CVA) sites), and the units consumed within the time periods specified in this statement.
- 2.17 All LLFCs/DUoS Tariff IDs are assigned at our sole discretion, based on the tariff application rules set out in the appropriate charging methodology or elsewhere in this statement. Please refer to the section 'Allocation of Charges' if you believe the allocated LLFC/DUoS Tariff ID or tariff is incorrect.

## **Site-Specific Billed Charges**

- 2.18 Site-specific billed charges for LV and HV Properties may include the following components:
- a fixed charge in pence/MPAN/day for SVA sites, or pence/MSID/day for CVA sites;
  - a capacity charge in pence/kilovolt-ampere (kVA)/day, for Maximum Import Capacity (MIC) and/or Maximum Export Capacity (MEC);
  - an exceeded capacity charge in pence/kVA/day, if a site exceeds its MIC and/or MEC;
  - three unit charges in pence/kWh, depending on the time of day and the type of tariff for which the MPAN is registered; and
  - a reactive power charge in pence/kilovolt-ampere reactive hour (kVArh), for each unit in excess of the reactive charge threshold.
- 2.19 Site-specific billed charges for properties that are under transitional protection arrangements for BSC Modification P432 or MHHS will include only fixed and unit charges, in the same manner as Supercustomer/Aggregate charges, as described in 2.8.
- 2.20 Users who wish to supply electricity to Customers for whom we receive site-specific data through Settlement (see paragraph 2.4) will be allocated the relevant charge structure dependent upon the voltage and location of the Metering Point.
- 2.21 Fixed charges are generally levied on a pence per MPAN/MSID per day basis.

- 2.22 LV and HV Properties will be charged in accordance with the relevant charge structure set out in Annex 1.
- 2.23 EHV Properties will be charged in accordance with the relevant charge structure set out in Annex 2.
- 2.24 Where LV and HV Properties or EHV Properties have more than one point of connection (as identified in the Connection Agreement) then separate charges will be applied to each point of connection.

### **Components of Charges**

#### ***Application of Residual Charges***

- 2.25 The following sections explain the application of residual charges.

#### ***Final Demand Sites***

- 2.26 Residual charges are recovered through fixed charges for all Final Demand Sites. All Non-Final Demand Sites must submit a valid certificate, as described in Section 10, and upon receipt of a valid certificate will be allocated to the relevant No Residual Tariff.
- 2.27 All Back-up Connections must provide clear supporting documentary evidence to the reasonable satisfaction of the LDNO, as described in Section 11, and upon receipt of sufficient evidence will be allocated to the relevant No Residual tariff.

### **Residual Charging Bands**

- 2.28 Residual charges are applied to Final Demand Sites on a banded basis, with all sites in a given charge band receiving the same residual charge. Domestic customers have a single charging band.
- 2.29 There are four non-domestic charging bands for each of the following groups:
- Properties connected at LV, billing with no MIC;
  - Properties connected at LV, billing with MIC;
  - Properties connected at HV; and
  - EHV Properties.
- 2.30 All non-domestic Final Demand customers are allocated into one of the four charging bands, for each relevant charge structure.
- 2.31 The residual charging band boundaries are calculated nationally based upon data from all LDNOs. The method and timing for calculating the residual charging band boundaries and the method and timing for allocating customers into the residual charging bands are set out in Schedule 32 of DCUSA.
- 2.32 The boundaries for the residual bands can be found in the 'Schedule of Charges and Other Tables' spreadsheet on our website, as well as the mapping between the DUoS Tariff name and TNUOS site charging band.

### **Time Periods**

- 2.33 The time periods for the application of unit charges to LV and HV Properties are detailed in Annex 1.
- 2.34 The time periods for the application of unit charges to Unmetered Supply Exit Points are detailed in Annex 1.
- 2.35 The time periods for the application of unit charges to EHV Properties are detailed in Annex 2.

### **Application of Capacity Charges**

- 2.36 The following sections explain the application of capacity charges and exceeded capacity charges.

#### **Chargeable Capacity**

- 2.37 The chargeable capacity is, for each billing period, the MIC and/or MEC as detailed below.
- 2.38 The MIC and/or MEC will be agreed with us at the time of connection or pursuant to a later change in requirements. Following such an agreement (be it at the time of connection or later) no reduction in MIC/MEC will be allowed for a 12 month period.
- 2.39 Reductions to the MIC/MEC may only be permitted once in a 12 month period. Where the MIC/MEC is reduced the new lower level will be agreed with reference to the level of the Customer's maximum import and/or export demand respectively. The new MIC/MEC will be applied from the start of the

next billing period after the date that the request was received. It should be noted that where a new lower level is agreed the original capacity may not be available in the future without the need for network reinforcement and associated charges.

- 2.40 In the absence of an agreement, the chargeable capacity, save for error or omission, will be based on the last MIC/MEC previously agreed by us for the relevant premises' connection. A Customer can seek to agree or vary the MIC/MEC by contacting us using the contact details in section 1.

### **Exceeded Capacity**

- 2.41 Where a Customer takes additional unauthorised capacity over and above the MIC/MEC, the excess will be classed as exceeded capacity. The exceeded portion of the capacity will be charged at the exceeded capacity charge p/kVA/day rate, based on the difference between the MIC/MEC and the actual capacity used. This will be charged for the duration of the full month in which the breach occurs.

### **Demand Exceeded Capacity**

$$\text{Demand Exceeded Capacity} = \text{Max}(2 \times \sqrt{\text{AI}^2 + \max(\text{RI}, \text{RE})^2} - \text{MIC}, 0)$$

Where:

AI = Active Import (kWh)

RI = Reactive Import (kVAh)

RE = Reactive Export (kVAh)

MIC = Maximum Import Capacity (kVA)

- 2.42 Only reactive import and reactive export values occurring at times of active import are used in the calculation. Where data for two or more MPANs is aggregated for billing purposes the HH consumption values are summated prior to the calculation above.
- 2.43 This calculation is completed for every half hour and the maximum value from the billing period is applied.

### **Generation Exceeded Capacity**

$$\text{Generation Exceeded Capacity} = \text{Max}(2 \times \sqrt{\text{AE}^2 + \max(\text{RI}, \text{RE})^2} - \text{MEC}, 0)$$

Where:

AE = Active Export (kWh)

RI = Reactive Import (kVAh)

RE = Reactive Export (kVAh)

MEC = Maximum Export Capacity (kVA)

- 2.44 Only reactive import and reactive export values occurring at times of active export are used in the calculation. Where data for two or more MPANs is aggregated for billing purposes the HH consumption values occurring at times of kWh export are summated prior to the calculation above.
- 2.45 This calculation is completed for every half hour and the maximum value from the billing period is applied.

### **Standby Capacity for Additional Security on Site**

- 2.46 Where standby capacity charges are applied, the charge will be set at the same rate as that applied to the normal MIC. Should a Customer's request for additional security of supply require the provision of capacity from two different sources, we reserve the right to charge for the capacity held at each source.

### **Minimum Capacity Levels**

- 2.47 There is no minimum capacity threshold.

### **Application of charges for reactive power**

- 2.48 When an individual HH metered MPAN's reactive power (measured in kVAh) at LV and HV Properties exceeds 33% of its total active power (measured in kWh), reactive power charges will apply. This threshold is equivalent to an average power factor of 0.95 during the period. Any reactive units in excess of the 33% threshold are charged at the rate appropriate to the particular charge.
- 2.49 Power Factor is calculated as follows:

Cos  $\theta$  = Power Factor

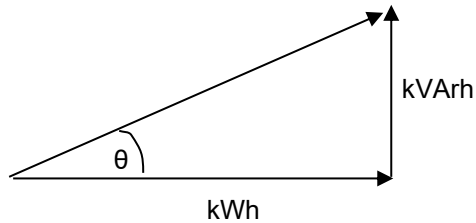

2.50 The chargeable reactive power is calculated as follows:

#### Demand Chargeable Reactive Power

$$\text{Demand Chargeable kVArh} = \max \left( \max(\text{RI}, \text{RE}) - \left( \sqrt{\left( \frac{1}{0.95^2} - 1 \right)} \times \text{AI} \right), 0 \right)$$

Where:

AI = Active Import (kWh)

RI = Reactive Import (kVArh)

RE = Reactive Export (kVArh)

2.51 Only reactive import and reactive export values occurring at times of active import are used in the calculation. Where data for two or more MPANs is aggregated for billing purposes the HH consumption values are summated prior to the calculation above.

2.52 The square root calculation will be to two decimal places.

2.53 This calculation is completed for every half hour and the values summated over the billing period.

#### Generation Chargeable Reactive Power

$$\text{Generation Chargeable kVArh} = \max \left( \max(\text{RI}, \text{RE}) - \left( \sqrt{\left( \frac{1}{0.95^2} - 1 \right)} \times \text{AE} \right), 0 \right)$$

Where:

AE = Active Export (kWh)

RI = Reactive Import (kVArh)

RE = Reactive Export (kVArh)

2.54 Only reactive import and reactive export values occurring at times of active export are used in the calculation. Where data for two or more MPANs is aggregated for billing purposes the HH consumption values are summated prior to the calculation above.

2.55 The square root calculation will be to two decimal places.

2.56 This calculation is completed for every half hour and the values summated over the billing period.

#### Allocation of Charges

2.57 It is our responsibility to apply the correct charges to each MPAN/MSID. The allocation of charges is based on the voltage of connection, import/export details including multiple MPANs, metering information and, for some tariffs, the metering location.

2.58 We are responsible for deciding the voltage of connection. Generally, this is determined by where the metering is located and where responsibility for the electrical equipment transfers from us to the connected Customer.

2.59 We are also responsible for allocating non-domestic customers into their residual charging bands. Allocation into residual charging bands is determined by consumption for customers billed under the Supercustomer/Aggregated approach and for properties that are under transitional protection arrangements for BSC Modification P432 or MHHS, and by the MIC for all other customers billed under the site-specific approach.

2.60 The Supplier determines and provides us with the metering information and data. This enables us to allocate charges where there is more than one charge per voltage level. The metering information and

data is likely to change over time if, for example, a Supplier changes from a two rate meter to a single rate meter. When we are notified this has happened we will change the allocation of charges accordingly.

- 2.61 If it has been identified that a charge has been incorrectly allocated due to the metering information and/or data then a correction request should be made to the Supplier.
- 2.62 Where it has been identified that:
- (a) a charge is likely to be incorrectly allocated due to the voltage of connection, import/export details or metering location, or allocation to residual charging band; or
  - (b) a connection may be eligible for Low Voltage Substation tariff(s);
- a request to investigate the applicable charges should be made to us. Requests from persons other than the Customer or the current Supplier must be accompanied by a Letter of Authority from the Customer and the current Supplier must also acknowledge that they are aware a request has been made. Any request must be supported by an explanation of why it is believed that the current charge should be changed, along with supporting information including, where appropriate, photographs of metering positions or system diagrams. Any request to change the current charge that also includes a request for backdating must include justification as to why it is considered appropriate to backdate the change.
- 2.63 Where a residual charging band allocation cannot be resolved, the process provided within DCUSA Schedule 32 should be followed.
- 2.64 An administration charge (covering our reasonable costs) may be made if a technical assessment or site visit is required, but we will not apply any charge where we agree to the change request.
- 2.65 Where we agree that the current LLFC/DUoS Tariff ID charge should be changed, we will then allocate the appropriate set of charges for the connection. Any adjustment will be applied from the date of the request back to either:
- (a) the date of incorrect allocation in respect of paragraphs 2.61 or 2.62(a); or
  - (b) up to the maximum period specified by the Limitation Act (1980) in England and Wales, which covers a six year period;
- whichever is the shorter.
- 2.66 Any credit or additional charge will be issued to the relevant Supplier(s) effective during the period of the change.
- 2.67 Should we reject the request (as per paragraph 2.62) a justification will be provided to the requesting Party. We shall not unreasonably withhold or delay any decision on a request to change the charges applied and would expect to confirm our position on the request within three months of the date of request.

#### **Generation Charges for Pre-2005 EHV Properties**

- 2.68 EHV Properties that were connected to our Embedded Networks under a pre-2005 connection charging policy are eligible for exemption from DUoS charges for generation unless one of the following criteria has been met:
- 25 years have passed since their first energisation/connection date i.e. EHV Properties with Connection Agreements dated prior to 1st April 2005, and for which 25 years has passed since their first energisation/connection date will receive DUoS charges for generation from the next charging year following the expiry of their 25 years exemption starting 1st April, or
  - the person responsible for the EHV Property has provided notice to us that they wish to opt in to DUoS charges for generation.
- If a notice to opt in has been provided there will be no further opportunity to opt out.
- 2.69 Furthermore, if an exempt Customer makes an alteration to its export requirement then the Customer may be liable to be charged for the additional capacity required for energy imported or exported. For example, where a generator increases its export capacity the incremental increase in export capacity will attract DUoS charges as with other non-exempt generators.

## **Provision of billing data**

- 2.70 Where HH metering data is required for DUoS charging and this is not provided in accordance with the BSC or DCUSA, such metering data shall be provided by the User of the system to us in respect of each calendar month within five working days of the end of that calendar month.
- 2.71 The metering data shall identify the amount of energy conveyed across the Metering System in each half hour of each day and shall separately identify active and reactive import and export. Metering data provided to us shall be consistent with that received through the metering equipment installed.
- 2.72 Metering data shall be provided in an electronic format specified by us from time to time and in the absence of such specification, metering data shall be provided in a comma separated text file in the format of data flow D0275<sup>4</sup> for Non-Migrated MPANs, and the IF-21 message for Migrated MPANs (as agreed with us). The data shall be e-mailed to [duos.income.billing@sse.com](mailto:duos.income.billing@sse.com).
- 2.73 We require details of reactive power imported or exported to be provided for all Measurement Class C and E sites for Non-Migrated MPANs, and for all Migrated MPANs with a connection type of 'L', 'H', or 'E'. It is also required for CVA sites and network boundaries with difference metering. We reserve the right to levy a charge on Users who fail to provide such reactive data. In order to estimate missing reactive data, a power factor of 0.95 lag will be applied to the active consumption in any half hour.

## **Licensed Distributor Network Operator charges**

- 2.74 Licensed Distribution Network Operator (LDNO) charges are applied to LDNOs who operate Embedded Networks.
- 2.75 The charge structure for LV and HV Properties reflects the Host DNO's LV and HV Properties' charges. The relevant charge structures are set out in Annex 4.
- 2.76 Where a NHH metered MPAN has an invalid Settlement combination, the 'LDNO HV: Domestic Aggregated with Residual' fixed and unit charges will be applied as default until the invalid combination is corrected. Where there are multiple SSC/TPR combinations for Non-Migrated MPANs, the default 'LDNO HV: Domestic Aggregated with Residual' fixed and unit charges will be applied for each invalid TPR combination.
- 2.77 The charge structure for EHV Properties connected to Embedded Networks operated by us will be calculated individually and includes the Host DNO's boundary charges. The relevant charge structures are set out in Annex 2.
- 2.78 For Nested Networks the relevant charging principles set out in DCUSA Schedule 21 will apply.

## **Licence exempt distribution networks**

- 2.79 The Electricity and Gas (Internal Market) Regulations 2011<sup>5</sup> introduced obligations on owners of licence exempt distribution networks (sometimes called private networks) including a duty to facilitate access to electricity and gas Suppliers for Customers within those networks.
- 2.80 When Customers (both domestic and commercial) are located within a licence exempt distribution network and require the ability to choose their own Supplier this is called 'third party access'. These embedded Customers will require an MPAN so that they can have their electricity supplied by a Supplier of their choice.
- 2.81 Licence exempt distribution networks owners can provide third party access using either full settlement metering or the difference metering approach.<sup>6</sup>

## **Full settlement metering**

- 2.82 This is where a licence exempt distribution network is set up so that each embedded installation has an MPAN and Metering System and therefore all Customers purchase electricity from their chosen

---

<sup>4</sup> Data Transfer Catalogue available from <https://www.electralink.co.uk/dtc-catalogue>

<sup>5</sup> The Electricity and Gas (Internal Market) Regulations 2011 available from <http://www.legislation.gov.uk/ukxi/2011/2704/contents/made>

<sup>6</sup> Elexon's guide is available from <https://www.elexon.co.uk/guidance-note/third-party-access-licence-exempt-distribution-networks/>

Supplier. In this case there are no Settlement Metering Systems at the boundary between our Embedded Network and the licence exempt distribution network.

2.83 In this approach our DUoS charges may be applied to each MPAN.

### **Difference metering**

2.84 This is where one or more, but not all, Customers on a licence exempt distribution network choose their own Supplier for electricity supply to their premises. Under this approach the Customers requiring third party access on the licence exempt distribution network will have their own MPAN and must have a HH Metering System.

### **Shared metering**

2.85 This is where one or more Customers on a license exempt distribution network choose their own Supplier for electricity supply to their premises, and the active import and/or active export meter readings at the boundary are apportioned between the Suppliers. Under this approach, the Customers requiring third party access on the license exempt distribution network will have their own MPAN and must have a HH Metering System.

2.86 In this approach our DUoS charges may be applied to each MPAN.

### **Gross settlement**

2.87 Where one of our MPANs (prefixed by the number 20) is embedded within a licence exempt distribution network connected to our Embedded Network, and difference metering is in place for Settlement purposes and we receive gross measurement data for the boundary MPAN, we will continue to charge the boundary MPAN Supplier for use of our Embedded Network. No charges will be levied by us directly to the Customer or Supplier of the embedded MPAN(s) connected within the licence exempt distribution network.

2.88 We require that gross metered data for the boundary of the connection is provided to us. Until a new industry data flow is introduced for the sending of such gross data, gross metered data shall:

- be provided in a text file in the format of the D0036 or D0275 data flow;
- the text file shall be emailed to [duos.income.billing@sse.com](mailto:duos.income.billing@sse.com);
- the title of the email should also contain the phrase “gross data for difference metered private network” and contain the metering reference specified by us in place of the Settlement MPAN; and
- the text filename shall be formed of the metering reference specified by us followed by a hyphen and followed by a timestamp in the format YYYYMMDDHHMMSS and followed by “.txt”.

2.89 For the avoidance of doubt, the reduced difference metered measurement data for the boundary connection that is to enter Settlement should continue to be sent using the Settlement MPAN.

### **3. Schedule of Charges for use of our Embedded Networks**

- 3.1 Tables listing the charges for use of our Embedded Networks are published in the annexes to this document.
- 3.2 These charges are also listed in a spreadsheet which is published with this statement and can be downloaded from our website [www.ssen.co.uk](http://www.ssen.co.uk).
- 3.3 Annex 1 contains the charges applied to LV and HV Properties.
- 3.4 Annex 2 contains the charges applied to EHV Properties, which includes charges applied to LDNOs for end user EHV Properties embedded in networks which are connected to our Embedded Networks.
- 3.5 Annex 3 contains details of any preserved and additional charges that are valid at this time. Preserved charges are mapped to an appropriate charge and are closed to new Customers.
- 3.6 Annex 4 contains the charges applied to LDNOs in respect of LV and HV Properties embedded in networks which are connected to our Embedded Networks.

## 4. Schedule of Line Loss Factors

### Role of Line Loss Factors in the Supply of Electricity

- 4.1 Electricity entering or exiting our Embedded Networks is adjusted to take account of energy that is lost<sup>7</sup> as it is distributed through the networks. This adjustment does not affect distribution charges but is used in energy settlement to take metered consumption to a notional Grid Supply Point so that Suppliers' purchases take account of the energy lost on the Distribution System.
- 4.2 We are responsible for calculating the Line Loss Factors (LLFs) and providing these to Elexon. Elexon is the company that manages the BSC.
- 4.3 LLFs are used to adjust the Metering System volumes to take account of losses on the Distribution System.

### Calculation of Line Loss Factors

- 4.4 LLFs are calculated in accordance with BSCP128 which sets out the procedures and principles with which our LLF methodology must comply. It also defines the procedure and timetable by which LLFs are reviewed and submitted.
- 4.5 LLFs are calculated for a set number of time periods during the year, using either a generic or a site specific method. The generic method is used for sites connected at LV or HV and the site specific method is used for sites connected at EHV or where a request for site specific LLFs has been agreed. Generic LLFs will be applied as a default to all new EHV sites until sufficient data is available for a site specific calculation.

Where the usage profile for a given site contains insufficiently large consumption or generation volumes to enable calculation of realistic Site Specific LLFs then a default calculation, or default replacement process shall be undertaken.

A default replacement process shall be deemed to have been undertaken if a generic methodology is used where the following applies:

- (a) A Site has multiple connections to the Total System and the primary connection is at EHV but there is a subordinate connection that is not connected at EHV, then a generic methodology MAY be used for the subordinate connection (even if a Site specific LLF is used for the Site's primary connection); and
- (b) The connection has a capacity of less than or equal to 1MVA

The definition of EHV used for LLF purposes differs from the definition used for defining EHV Properties that is used for charging purposes. The definition used for LLF purposes can be found in our LLF methodology which can be found on the Elexon website<sup>8</sup>.

### Publication of Line Loss Factor tables

- 4.6 The LLFs used in Settlement are published on the Elexon Portal website<sup>9</sup>. The website contains the LLFs in standard industry data formats and in a summary form. A user guide with details on registering and using the portal is also available.
- 4.7 BSCP 128 sets out the timetable by which LLFs are submitted and audited. The submission and audit occurs between September and December in the year prior to the LLFs becoming effective. Only after the completion of the audit at the end of December and BSC approval are the final LLFs published.
- 4.8 At the time that this charging statement is first published, Annex 5 will be intentionally left blank, as this statement is published a complete year before the LLFs have been calculated and audited. Once the final BSCP 128 Audit Report has been received, we will issue an updated version of Annex 5 containing the audited LLF values.

---

<sup>7</sup> Energy can be lost for technical and non-technical reasons and losses normally occur by heat dissipation through power flowing in conductors and transformers. Losses can also reduce if a Customer's action reduces power flowing in the distribution network. This might happen when a Customer generates electricity and the produced energy is consumed locally.

<sup>8</sup> The following page has links to BSCP128 and to our LLF methodology: <http://www.elexon.co.uk/reference/technical-operations/losses/>

<sup>9</sup> The Elexon Portal can be accessed from [www.elexonportal.co.uk](http://www.elexonportal.co.uk)

4.9 When using the tables in Annex 5, reference should be made to the LLFC allocated to a Non-Migrated MPAN or to the DUoS Tariff ID allocated to a Migrated MPAN to find the appropriate values.

## 5. Notes for EHV Properties

### Charges for EHV Properties

- 5.1 The charges for EHV Properties are based on information available at the time that this statement was published. A new or modified connection will result in changes to current network utilisations which will then form the basis of future prices: the charge determined in this statement will not necessarily be the charge in subsequent years because of the interaction between new and existing network connections and any other changes made to the Embedded Networks or Host DNO systems which may affect the charges.

### Charges for New EHV Properties

- 5.2 Charges for any new EHV Properties calculated after publication of the current statement will be published on our website in an addendum to that statement as and when necessary. The addendum will include charge information of the type found in Annex 2, and LLFs as found in Annex 5.
- 5.3 The form of the addendum is detailed in Annex 6 of this statement.
- 5.4 The new EHV Properties' charges will be added to Annex 2 in the next full statement released.

### Charges for Amended EHV Properties

- 5.5 Where an existing EHV Property connection is modified and energised in the charging year, we may revise our charges for the modified EHV Property. If revised charges are appropriate, an addendum will be sent to all relevant parties and published as a revised 'Schedule of Charges and Other Tables' spreadsheet on our website [www.ssen.co.uk](http://www.ssen.co.uk). The modified EHV Property charges will be added to Annex 2 in the next full statement released.

### Demand Side Management

- 5.6 New or existing EHV Properties may wish to offer part of their MIC to be interruptible by us (for active network management purposes other than normal planned or unplanned outages) in order to benefit from any reduced DUoS charges.
- 5.7 Several options exist in which we may agree for some or the entire MIC to be interruptible. The applicable demand capacity costs would be based on the MIC minus the capacity subject to interruption.
- 5.8 If you are interested in making part or all of your MIC interruptible as an integral irrevocable feature of a new connection or modification to an existing connection you should in the first instance contact our connections function;  
[connections@ssen.co.uk](mailto:connections@ssen.co.uk)

You must make an express statement in your application that you have an interest in some or all of the import capacity being interruptible for active network management purposes.

- 5.9 If you are proactively interested in voluntarily but revocably offering to make some or all of your existing connection's MIC interruptible you should in the first instance contact us at the address in paragraph 5.8.

## **6. Electricity Distribution Rebates**

- 6.1 We have neither given nor announced any DUoS rebates to Users in the 12 months preceding the date of publication of this version of the statement.

## 7. Accounting and Administration Services

- 7.1 Other than the charges noted below, no Accounting and Administration charges are detailed within this statement. Please refer to our Statement of Miscellaneous Charges for details of our transactional charges and other notices.
- 7.2 We reserve the right to impose payment default remedies. The remedies are as set out in the DCUSA where applicable or else as detailed in the following paragraph.
- 7.3 If any invoices that are not subject to a valid dispute remain unpaid on the due date, late payment interest (calculated at Base Rate plus 8%) and administration charges may be imposed.
- 7.4 Our administration charges are detailed in the following table. These charges are set at a level which is in line with the Late Payment of Commercial Debts Act;

Size of Unpaid Debt	Late Payment Fee
Up to £999.99	£40.00
£1,000 to £9,999.99	£70.00
£10,000 or more	£100.00

## **8. Charges for electrical plant provided ancillary to the grant of Use of System**

- 8.1 No charges for electrical plant provided ancillary to the grant of Use of System are detailed within this statement. Please refer to our Statement of Miscellaneous Charges for details of transactional charges and other notices.

## **9. Schedule of fixed adders to recover Supplier of Last Resort and Eligible Bad Debt pass-through costs**

### **Supplier of Last Resort**

- 9.1 In accordance with Standard Condition 38B 'Last Resort Supply Payment Claims' ('SLC38B') and Special Condition 6 'Pass-through expenditure' ('SpC6') of our Electricity Distribution Licence, our charges will recover the amount of payments in Regulatory Year t made in response to Last Resort Supply Payment claims.

### **Eligible Bad Debt**

- 9.2 In accordance with SpC6, our charges will recover the amount of use of system bad debt the Authority has consented to be recovered. This represents use of system bad debt our charges are recovering on behalf of Independent Distribution Network Operators (IDNOs), in accordance with Standard Licence Condition 38C 'Treatment of Valid Bad Debt Claims' ('SLC38C'), and specifically paragraph 4 of that condition.

### **Tables of Fixed Adders**

- 9.3 Tables listing the charges to recover Supplier of Last Resort and Eligible Bad Debt pass-through costs are published in Annex 7 to this document. The charges are shown for information only and are already included in the final Annex 1 charges.

## 10. Non-Final Demand Sites

### Charges for Non-Final Demand Sites

- 10.1 A Non-Final Demand Site is charged an import tariff that excludes the residual cost element of charges. If the User wishes for a property to qualify for allocation to these tariffs, then the User must submit certification declaring that the property meets the required criteria as per DCUSA.

### Process for submitting certification

- 10.2 This certification should take the form as set out in Appendix 3 and be submitted to Authorised Capacity using the contact details in 1.14.

We may, at our discretion, request a signed paper certificate from the User, in place of electronic. If requested, paper certification should be posted to the contact details in 1.14.

- 10.3 Users should undertake reasonable endeavours to ensure the facts attested to in the certification are true. We may request documentation evidencing these endeavours, including where appropriate, photographs of metering positions or system diagrams, following receipt of the certification.
- 10.4 If we determine that the documentation provided does not sufficiently evidence the undertaking of reasonable endeavours, does not support the facts attested to in the certification, or if no documentation is received, we may at our discretion reject the certification as invalid. If the certification is rejected as invalid, then the property will not qualify as a Non-Final Demand Site.

### Application of charges for Non-Final Demand Site

- 10.5 A property will only be deemed to qualify as a Non-Final Demand Site, and be allocated charges as such, from the date on which we receive valid certification.
- 10.6 If a property that has previously been certified as a Non-Final Demand Site no longer satisfies the criteria as per DCUSA, then the User must inform us immediately.
- 10.7 For a property that has been previously certified as a Non-Final Demand Site, we will continue to apply the relevant no residual import tariff without the requirement for further certification, except in any one of the following circumstances:
- (a) Where we have reason to believe that the property no longer qualifies as a Non-Final Demand Site; or,
  - (b) Significant time has passed since the certification was submitted; or,
  - (c) Where there is a change to the connection characteristics i.e. capacity change.

If such circumstances occur, we may request re-certification of the site, or reject the certification as invalid at our discretion.

- 10.8 When a property no longer meets the required criteria to qualify as a Non-Final Demand Site, we will change the allocation of charges accordingly from that point.
- 10.9 Please refer to the section 'Allocation of Charges' if you believe the property has been incorrectly not allocated charges as a Non-Final Demand Site.

## 11. Back-up Connections

### Charges for Back-up Connections

- 11.1. A Back-up Connection is charged an import tariff that excludes the residual cost element of charges. If the User wishes for a MPAN/MSID to qualify for allocation to these tariffs, then the User must provide evidence necessary to satisfy the definition of Back-up Connection as per DCUSA.

### Process for providing evidence

- 11.2. Users should undertake reasonable endeavours to ensure the facts attested to in the request are true. We may request documentation evidencing these endeavours, including where appropriate, photographs of metering positions or system diagrams.
- 11.3. If we determine that the documentation provided does not sufficiently evidence the undertaking of reasonable endeavours, does not support the facts attested to in the request, or if no documentation is received, we may at our discretion reject the evidence as invalid. If the evidence is rejected as invalid, then the property will not qualify as a Back-up Connection.

### Application of charges for Back-up Connections

- 11.4. A MPAN/MSID will only be deemed to qualify as a Back-up Connection, and be allocated charges as such, from the first of the month following the date on which we receive valid evidence.
- 11.5. If a MPAN/MSID that has previously been appointed as a Back-up Connection no longer satisfies the criteria as per DCUSA, then the User must inform us immediately.
- 11.6. For a MPAN/MSID that has been previously certified as a Back-up Connection, we will continue to apply the relevant no residual import tariff without the requirement for further certification, except in any one of the following circumstances:
- (a) Where we have reason to believe that the MPAN/MSID no longer qualifies as a Back-up Connection; or
  - (b) Significant time has passed since the evidence was submitted; or
  - (c) Where there is a change to the connection characteristics i.e. capacity change.

If such circumstances occur, we may request evidence to be provided again for the site, or reject the evidence as invalid at our discretion.

- 11.7. When a MPAN/MSID no longer meets the required criteria to qualify as a Back-up Connection, we will change the allocation of charges accordingly from that point.
- 11.8. Please refer to the section 'Allocation of Charges' if you believe the MPAN/MSID has been incorrectly not allocated charges as a Back-up Connection.

## Appendix 1 – Glossary

1.1. The following definitions, which can extend to grammatical variations and cognate expressions, are included to aid understanding:

Term	Definition
Back-up Connection	As defined in DCUSA Schedule 32.
Balancing and Settlement Code (BSC)	The BSC contains the governance arrangements for electricity balancing and settlement in Great Britain. An overview document is available from <a href="https://www.elexon.co.uk/bsc-and-codes/balancing-settlement-code/">https://www.elexon.co.uk/bsc-and-codes/balancing-settlement-code/</a>
Balancing and Settlement Code Procedure (BSCP)	A document of that title, as established or adopted and from time to time modified by the Panel in accordance with The Code, setting out procedures to be complied with (by Parties, Party Agents, BSC Agents, BSCCo, the Panel and others) in, and other matters relating to, the implementation of The Code;
Connection Agreement	An agreement between an LDNO and a Customer which provides that the Customer has the right for its connected installation to be and remain directly or indirectly connected to that LDNO's Distribution System.
Connection Type	Defines the physical connection as one of four valid types for metered supplies: 'W' Whole Current; 'L' Low Voltage (LV) Current Transformer; 'H' High Voltage (HV) Current Transformer; or 'E' Extra High Voltage (EHV) Current Transformer (E). It will also include a value of 'U' for unmetered connections.
Central Volume Allocation (CVA)	As defined in the BSC.
Customer	A person to whom a User proposes to supply, or for the time being supplies, electricity through an exit point, or from whom, a User or any relevant exempt Supplier, is entitled to recover charges, compensation or an account of profits in respect of electricity supplied through an exit point;  or  A person from whom a User purchases, or proposes to purchase, electricity, at an entry point (who may from time to time be supplied with electricity as a Customer of that User (or another electricity Supplier) through an exit point).
Distribution Connection and Use of System Agreement (DCUSA)	The DCUSA is a multi-party contract between the licensed electricity distributors, suppliers, generators and Offshore Transmission Owners of Great Britain. It is a requirement that all licensed electricity distributors and suppliers become parties to the DCUSA.

Term	Definition																																																																																																																		
Distributor IDs	<p>These are unique IDs that can be used, with reference to the MPAN, to identify your LDNO. The charges for other network operators can be found on their website.</p>																																																																																																																		
	<table border="1"> <thead> <tr> <th data-bbox="496 344 571 376">ID</th> <th data-bbox="571 344 927 376">Distribution Service Area</th> <th data-bbox="927 344 1409 376">Company</th> </tr> </thead> <tbody> <tr><td>10</td><td>East of England</td><td>UK Power Networks</td></tr> <tr><td>11</td><td>East Midlands</td><td>Western Power Distribution</td></tr> <tr><td>12</td><td>London</td><td>UK Power Networks</td></tr> <tr><td>13</td><td>Merseyside and North Wales</td><td>Scottish Power</td></tr> <tr><td>14</td><td>Midlands</td><td>Western Power Distribution</td></tr> <tr><td>15</td><td>Northern</td><td>Northern Powergrid</td></tr> <tr><td>16</td><td>North Western</td><td>Electricity North West</td></tr> <tr><td>17</td><td>Scottish Hydro Electric (and embedded networks in other areas)</td><td>Scottish Hydro Electric Power Distribution plc</td></tr> <tr><td>18</td><td>South Scotland</td><td>Scottish Power</td></tr> <tr><td>19</td><td>South East England</td><td>UK Power Networks</td></tr> <tr><td>20</td><td>Southern Electric (and embedded networks in other areas)</td><td>Southern Electric Power Distribution plc</td></tr> <tr><td>21</td><td>South Wales</td><td>Western Power Distribution</td></tr> <tr><td>22</td><td>South Western</td><td>Western Power Distribution</td></tr> <tr><td>23</td><td>Yorkshire</td><td>Northern Powergrid</td></tr> <tr><td>24</td><td>All</td><td>Independent Power Networks</td></tr> <tr><td>25</td><td>All</td><td>ESP Electricity</td></tr> <tr><td>26</td><td>All</td><td>Last Mile Electricity Ltd</td></tr> <tr><td>27</td><td>All</td><td>The Electricity Network Company Ltd</td></tr> <tr><td>29</td><td>All</td><td>Harlaxton Energy Networks</td></tr> <tr><td>30</td><td>All</td><td>Peel Electricity Networks Ltd</td></tr> <tr><td>31</td><td>All</td><td>UK Power Distribution Ltd</td></tr> <tr><td>32</td><td>All</td><td>Energy Assets Networks Limited</td></tr> <tr><td>33</td><td>All</td><td>Eclipse Power Networks Ltd</td></tr> <tr><td>34</td><td>All</td><td>Murphy Power Distribution Ltd</td></tr> <tr><td>35</td><td>All</td><td>Fulcrum Electricity Assets Ltd</td></tr> <tr><td>36</td><td>All</td><td>Vattenfall Networks Ltd</td></tr> <tr><td>37</td><td>All</td><td>Forbury Assets Limited</td></tr> <tr><td>38</td><td>All</td><td>Indigo Power Limited</td></tr> <tr><td>39</td><td>All</td><td>Stark Infra-Electricity Ltd</td></tr> <tr><td>40</td><td>All</td><td>Utility Assets Limited</td></tr> <tr><td>42</td><td>All</td><td>Advanced Electricity Networks</td></tr> <tr><td>43</td><td>All</td><td>IDCSL</td></tr> <tr><td>45</td><td>All</td><td>Aurora Utilities Limited</td></tr> <tr><td>46</td><td>All</td><td>Aidien Limited</td></tr> <tr><td>47</td><td>All</td><td>Vital Energi Power Networks</td></tr> <tr><td>48</td><td>All</td><td>E.ON UK Network Assets Limited</td></tr> <tr><td>51</td><td>All</td><td>AGR Networks Ltd</td></tr> </tbody> </table>	ID	Distribution Service Area	Company	10	East of England	UK Power Networks	11	East Midlands	Western Power Distribution	12	London	UK Power Networks	13	Merseyside and North Wales	Scottish Power	14	Midlands	Western Power Distribution	15	Northern	Northern Powergrid	16	North Western	Electricity North West	17	Scottish Hydro Electric (and embedded networks in other areas)	Scottish Hydro Electric Power Distribution plc	18	South Scotland	Scottish Power	19	South East England	UK Power Networks	20	Southern Electric (and embedded networks in other areas)	Southern Electric Power Distribution plc	21	South Wales	Western Power Distribution	22	South Western	Western Power Distribution	23	Yorkshire	Northern Powergrid	24	All	Independent Power Networks	25	All	ESP Electricity	26	All	Last Mile Electricity Ltd	27	All	The Electricity Network Company Ltd	29	All	Harlaxton Energy Networks	30	All	Peel Electricity Networks Ltd	31	All	UK Power Distribution Ltd	32	All	Energy Assets Networks Limited	33	All	Eclipse Power Networks Ltd	34	All	Murphy Power Distribution Ltd	35	All	Fulcrum Electricity Assets Ltd	36	All	Vattenfall Networks Ltd	37	All	Forbury Assets Limited	38	All	Indigo Power Limited	39	All	Stark Infra-Electricity Ltd	40	All	Utility Assets Limited	42	All	Advanced Electricity Networks	43	All	IDCSL	45	All	Aurora Utilities Limited	46	All	Aidien Limited	47	All	Vital Energi Power Networks	48	All	E.ON UK Network Assets Limited	51	All	AGR Networks Ltd
	ID	Distribution Service Area	Company																																																																																																																
	10	East of England	UK Power Networks																																																																																																																
	11	East Midlands	Western Power Distribution																																																																																																																
	12	London	UK Power Networks																																																																																																																
	13	Merseyside and North Wales	Scottish Power																																																																																																																
	14	Midlands	Western Power Distribution																																																																																																																
	15	Northern	Northern Powergrid																																																																																																																
	16	North Western	Electricity North West																																																																																																																
	17	Scottish Hydro Electric (and embedded networks in other areas)	Scottish Hydro Electric Power Distribution plc																																																																																																																
	18	South Scotland	Scottish Power																																																																																																																
	19	South East England	UK Power Networks																																																																																																																
	20	Southern Electric (and embedded networks in other areas)	Southern Electric Power Distribution plc																																																																																																																
	21	South Wales	Western Power Distribution																																																																																																																
	22	South Western	Western Power Distribution																																																																																																																
	23	Yorkshire	Northern Powergrid																																																																																																																
	24	All	Independent Power Networks																																																																																																																
	25	All	ESP Electricity																																																																																																																
	26	All	Last Mile Electricity Ltd																																																																																																																
	27	All	The Electricity Network Company Ltd																																																																																																																
	29	All	Harlaxton Energy Networks																																																																																																																
	30	All	Peel Electricity Networks Ltd																																																																																																																
	31	All	UK Power Distribution Ltd																																																																																																																
	32	All	Energy Assets Networks Limited																																																																																																																
	33	All	Eclipse Power Networks Ltd																																																																																																																
	34	All	Murphy Power Distribution Ltd																																																																																																																
	35	All	Fulcrum Electricity Assets Ltd																																																																																																																
	36	All	Vattenfall Networks Ltd																																																																																																																
	37	All	Forbury Assets Limited																																																																																																																
	38	All	Indigo Power Limited																																																																																																																
	39	All	Stark Infra-Electricity Ltd																																																																																																																
40	All	Utility Assets Limited																																																																																																																	
42	All	Advanced Electricity Networks																																																																																																																	
43	All	IDCSL																																																																																																																	
45	All	Aurora Utilities Limited																																																																																																																	
46	All	Aidien Limited																																																																																																																	
47	All	Vital Energi Power Networks																																																																																																																	
48	All	E.ON UK Network Assets Limited																																																																																																																	
51	All	AGR Networks Ltd																																																																																																																	

<b>Term</b>	<b>Definition</b>
Distribution Network Operator (DNO)	An electricity distributor that operates one of the 14 distribution services areas and in whose Electricity Distribution Licence the requirements of Section B of the standard conditions of that licence have effect.
Distribution Services Area	The area specified by the Gas and Electricity Markets Authority within which each DNO must provide specified distribution services.
Distribution System	<p>The system consisting (wholly or mainly) of electric lines owned or operated by an authorised distributor that is used for the distribution of electricity from:</p> <ul style="list-style-type: none"> <li>• Grid Supply Points or generation sets or other entry points</li> </ul> <p>to the points of delivery to:</p> <ul style="list-style-type: none"> <li>• Customers or Users or any transmission licensee in its capacity as operator of that licensee's transmission system or the Great Britain (GB) transmission system and includes any remote transmission assets (owned by a transmission licensee within England and Wales)</li> </ul> <p>that are operated by that authorised distributor and any electrical plant, electricity meters, and metering equipment owned or operated by it in connection with the distribution of electricity, but does not include any part of the GB transmission system.</p>
DUoS Tariff ID	An identifier assigned to an SVA metering system which is used to assign the use of system charges for Migrated MPANs
EHV Properties	Demand users and/or distributed generators metered at 22,000 volts or above, or metered at an EHV/HV substation.
Electricity Distribution Licence	The Electricity Distribution Licence granted or treated as granted pursuant to section 6(1) of the Electricity Act 1989.
Electricity Distributor	Any person who is authorised by an Electricity Distribution Licence to distribute electricity.
Embedded Network	An electricity Distribution System operated by an LDNO and embedded within another Distribution System.
Embedded Network report for DUoS – aggregated data	A report of data by IDNO's DUoS Tariff ID and by IDNO providing counts of MPANs and units consumed
Engineering Recommendation P2/7	A document of the Energy Networks Association, which defines minimum planning standards for security of supply and is referred to in Standard Licence Condition 24 of our Electricity Distribution Licence.
Entry Point	A boundary point at which electricity is exported onto a Distribution System from a connected installation or from another Distribution System, not forming part of the total system (boundary point and total system having the meaning given to those terms in the BSC).
Exit Point	A point of connection at which a supply of electricity may flow from the Distribution System to the Customer's installation or User's installation or the Distribution System of another person.
Extra-High Voltage (EHV)	Nominal voltages of 22kV and above.

<b>Term</b>	<b>Definition</b>
Final Demand Site	As defined in DCUSA Schedule 32
Gas and Electricity Markets Authority (GEMA)	As established by the Utilities Act 2000.
Grid Supply Point (GSP)	A metered connection between the National Grid Electricity Transmission system and the licensee's Distribution System at which electricity flows to or from the Distribution System.
GSP group	A distinct electrical system that is supplied from one or more GSPs for which total supply into the GSP group can be determined for each half hour.
High Voltage (HV)	Nominal voltages of at least 1kV and less than 22kV.
HV and LV Properties	Demand users and/or distributed generators metered below 22,000 volts.
Industry Standing Data (ISD)	Industry Standing Data (ISD) is the reference data used in Settlement processes under MHHS.
Intermittent Generation	Defined in DCUSA Schedule 16 as a generation plant where the energy source of the prime mover cannot be made available on demand, in accordance to the definitions in Engineering Recommendation P2/7.
Invalid Settlement Combination	A Settlement combination that is not recognised as a valid combination in market domain data - see <a href="https://www.elexonportal.co.uk/MDDVIEWER">https://www.elexonportal.co.uk/MDDVIEWER</a> .
kVA	Kilovolt ampere.
kVArh	Kilovolt ampere reactive hour.
kW	Kilowatt.
kWh	Kilowatt hour (equivalent to one "unit" of electricity).
LDSO report for DUoS – aggregated data	A report of data by DUoS Tariff ID and Supplier providing counts of MPANs and units consumed
Licensed Distribution Network Operator (LDNO)	The holder of a Licence to distribute electricity.
Line Loss Factor (LLF)	The factor that is used in Settlement to adjust the metering system volumes to take account of losses on the Distribution System for Non-Migrated MPANs.
Line Loss Factor Class (LLFC)	An identifier assigned to an SVA metering system which is used to assign the LLF and use of system charges.
Load Factor	$= \frac{\text{annual consumption (kWh)}}{\text{maximum demand (kW)} \times \text{hours in year}}$
Low Voltage (LV)	Nominal voltages below 1kV.
LV Substation Tariff	This tariff applies as described in DCUSA Schedule 16 Section 141, Note 3, where the metering CT is within, or abutting to the HV/LV substation transformation chamber.

Term	Definition
Market Domain Data (MDD)	MDD is a central repository of reference data available to all Users involved in Settlement. It is essential to the operation of SVA trading arrangements. More information can be found here <a href="#">Market Domain Data - Elexon BSC</a> .
Market Segment	<p>Market Segment is derived from the Meter Type and Connection Type using a defined set of business rules.</p> <p>There are three Market Segments:</p> <ul style="list-style-type: none"> <li>Smart and Non-Smart (Including Smart Meters with Settlement Period level data available, Smart Meters with only Register Readings available and Non-Smart Meters with Register Readings);</li> <li>Advanced (which are Advanced Metering Systems with Settlement Period level data available);</li> <li>Unmetered</li> </ul>
Market-Wide HH Settlement (MHHS)	Market-wide Half-Hourly Settlement (MHHS) is a key enabler of the flexibility to support the transition to Net Zero. The MHHS Programme will contribute to a more cost-effective electricity system, encouraging more flexible use of energy and helping consumers lower their bills.
Maximum Export Capacity (MEC)	The MEC of apparent power expressed in kVA that has been agreed can flow through the entry point to the Distribution System from the Customer's installation as specified in the connection agreement.
Maximum Import Capacity (MIC)	The MIC of apparent power expressed in kVA that has been agreed can flow through the exit point from the Distribution System to the Customer's installation as specified in the connection agreement.
Measurement Class	<p>A classification of Metering Systems used in the BSC which indicates how consumption is measured, i.e.:</p> <ul style="list-style-type: none"> <li>• Measurement Class A – non-half-hourly metering equipment;</li> <li>• Measurement Class B – non-half-hourly unmetered supplies;</li> <li>• Measurement Class C – half-hourly metering equipment at or above 100kW premises;</li> <li>• Measurement Class D – half-hourly unmetered supplies;</li> <li>• Measurement Class E – half-hourly metering equipment below 100kW premises, and from 5 November 2015, with current transformer;</li> <li>• Measurement Class F – half hourly metering equipment at below 100kW premises with current transformer or whole current, and at domestic premises; and</li> <li>• Measurement Class G – half hourly metering equipment at below 100kW premises with whole current and not at domestic premises.</li> </ul>
Meter Timeswitch Code (MTC)	MTCs are three digit codes allowing Suppliers to identify the metering installed in Customers' premises. They indicate whether the meter is single or multi-rate, pre-payment or credit, or whether it is 'related' to another meter. Further information can be found in MDD.
Metering Point	The point at which electricity that is exported to or imported from the licensee's Distribution System is measured, is deemed to be measured, or is intended to be measured and which is registered pursuant to the provisions of the REC. For the purposes of this statement, GSPs are not 'Metering Points'.

<b>Term</b>	<b>Definition</b>
Metering Point Administration Number (MPAN)	A number relating to a Metering Point under the REC.
Metering System	Particular commissioned metering equipment installed for the purposes of measuring the quantities of exports and/or imports at the exit point or entry point.
Metering System Identifier (MSID)	MSID is a term used throughout the BSC and its subsidiary documents and has the same meaning as MPAN as used under the REC.
Migrated MPANs	Migration refers to the process by which MPANs are migrated from the legacy arrangements to the new MHHS arrangements.
Nested Networks	This refers to a situation where there is more than one level of Embedded Network and therefore nested Distribution Systems between LDNOs (e.g. host DNO→primary nested DNO→ secondary nested DNO→Customer).
Non-Final Demand Site	As defined in DCUSA Schedule 32
Non-Intermittent Generation	Defined in DCUSA Schedule 16 as a generation plant where the energy source of the prime mover can be made available on demand, in accordance with the definitions in Engineering Recommendation P2/7.
Non-Migrated MPANs	This refers to the status when an MPAN is on the legacy arrangements and before migrating under MHHS.
Ofgem	Office of Gas and Electricity Markets – Ofgem is governed by GEMA and is responsible for the regulation of the distribution companies.
Profile Class (PC)	A categorisation applied to NHH MPANs and used in settlement to group Customers with similar consumption patterns to enable the calculation of consumption profiles.
Retail Energy Code (REC)	A code that consolidates the switching arrangements historically set out in the Master Registration Agreement (MRA) and the Supply Point Administration Agreement (SPAA) (for gas) into one dual-fuel code. Provides a governance mechanism to manage the processes established between electricity suppliers and distribution companies to enable electricity suppliers to transfer customers. It includes terms for the provision of Metering Point Administration Services (MPAS) Registrations.
Settlement	The determination and settlement of amounts payable in respect of charges (including reconciling charges) in accordance with the BSC.
Settlement Class (SC)	The combination of Profile Class, Line Loss Factor Class, Time Pattern Regime and Standard Settlement Configuration, by Supplier within a GSP group and used for Settlement.
Standard Settlement Configuration (SSC)	A standard metering configuration relating to a specific combination of Time Pattern Regimes.
Supercustomer	The method of billing Users for use of system on an aggregated basis, grouping together consumption and standing charges for all similar NHH metered Customers or aggregated HH metered Customers. Also referred to as Aggregate Billing.

<b>Term</b>	<b>Definition</b>
Supercustomer DUoS Report	A report of profiled data by Settlement Class providing counts of MPANs and units consumed.
Supplier	An organisation with a supply licence responsible for electricity supplied to and/or exported from a Metering Point.
Supplier Volume Allocation (SVA)	As defined in the BSC.
Time Pattern Regime (TPR)	The pattern of switching behaviour through time that one or more meter registers follow.
Unmetered Supplies	Exit points deemed to be suitable as unmetered supplies as permitted in the Electricity (Unmetered Supply) Regulations 2001 and where operated in accordance with BSC procedure 52010.
Use of System Charges	Charges which are applicable to those parties which use the Distribution System.
User	Someone that has a use of system agreement with the LDNO e.g. a Supplier, generator or other LDNO.

---

<sup>10</sup> Balancing and Settlement Code Procedures are available from [BSC Procedures - Elexon Digital BSC](#)

## Appendix 2 - Guidance notes<sup>11</sup>

### Background

- 1.1. The electricity bill from your Supplier contains an element of charge to cover electricity distribution costs. This distribution charge covers the cost of operating and maintaining a safe and reliable Distribution System that forms the 'wires' that transport electricity between the national transmission system and end users such as homes and businesses. Our Distribution System includes overhead lines, underground cables, as well as substations and transformers.
- 1.2. In most cases, your Supplier is invoiced for the distribution charge and this is normally part of your total bill. In some cases, for example business users, the Supplier may pass through the distribution charge as an identifiable line item on the electricity bill.
- 1.3. Where electricity is generated at a premises your Supplier may receive a credit for energy that is exported on to the Distribution System. These credits are intended to reflect that the exported generation may reduce the need for traditional demand led reinforcement of the Distribution System.
- 1.4. Understanding your distribution charges could help you reduce your costs and increase your credits. This is achieved by understanding the components of the charge to help you identify whether there may be opportunities to change the way you use the Distribution System.

### Meter point administration

- 1.5. We are responsible for managing the electricity supply points that are connected to our Distribution System. Typically every supply point is identified by a Meter Point Administration Number (MPAN). A few supply points may have more than one MPAN depending on the metering configuration (e.g. a school which may have an MPAN for the main supply and an MPAN for catering).
- 1.6. The full MPAN is a 21 digit number, preceded by an 'S' and includes supplementary data. The MPAN applicable to a supply point is found on the electricity bill from your Supplier. This number enables you to establish who your electricity distributor is, details of the characteristics of the supply and importantly the distribution charges that are applicable to your premises.
- 1.7. The 21-digit number is normally presented in two sections as shown in the following diagram. The top section is supplementary data which gives information about the characteristics of supply, while the bottom 'core' is the unique identifier.

Full MPAN diagram

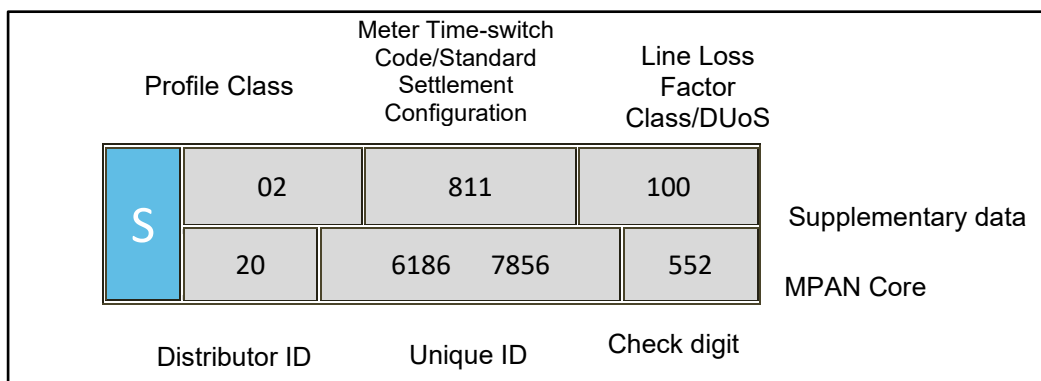

- 1.8. Generally, you will only need to know the Distributor ID and LLFC/DUoS Tariff ID to identify the distribution charges for your premises. However, there are some premises where charges are

<sup>11</sup> These guidance notes are provided for additional information and do not form part of the application of charges.

- specific to that site. In these instances the charges are identified by the core MPAN. The Distributor ID for SEPD is 20. Other Distributor IDs can be referenced in the Glossary.
- 1.9. Additionally, it can be useful to understand the profile class provided in the supplementary data. The profile class will be a number between 00 and 08. The following list provides details of the allocation of profile classes to types of Customers:
- '01' – Domestic Customers with unrestricted supply
  - '02' – Domestic Customers with restricted load, for example off-peak heating
  - '03' – Non-domestic Customers with unrestricted supply
  - '04' – Non-domestic Customers with restricted load, for example off-peak heating
  - '05' – Non-domestic maximum demand Customers with a Load Factor of less than 20%
  - '06' – Non-domestic maximum demand Customers with a Load Factor between 20% and 30%
  - '07' – Non-domestic maximum demand Customers with a Load Factor between 30% and 40%
  - '08' – Non-domestic maximum demand Customers with a Load Factor over 40% or non-half-hourly metered generation Customers
  - '00' – Half-hourly metered demand and generation Customers (including all Migrated MPANs)
- 1.10. Unmetered Supplies will be allocated to profile class 01, 08 or 00 depending on the type of load or the measurement method of the load.
- 1.11. The allocation of the profile class will affect your charges for Non-Migrated MPANs. If you feel that you have been allocated the wrong profile class, please contact your Supplier as they are responsible for this.

### **Your charges**

- 1.12. All distribution charges that relate to our Distributor ID 20 and to premises connected to our Embedded Networks are provided in this statement.
- 1.13. You can identify your charges by referencing your LLFC/DUoS Tariff ID, from Annex 1. If the MPAN is for an EHV Property then the charges will be found in Annex 2. In a few instances, the charges may be contained in Annex 3 or Annex 6. When identifying charges in Annex 2, please note that some LLFCs/DUoS Tariff IDs have more than one charge. In this instance you will need to select the correct charge by cross referencing with the MPAN core provided in the table.
- 1.14. Once you have identified which charge structure applies to your MPAN then you will be able to calculate an estimate of your distribution charge using the calculator provided in the spreadsheet 'Schedule of Charges and Other Tables' found in the sheet called 'Charge Calculator'. This spreadsheet can be downloaded from [www.ssen.co.uk](http://www.ssen.co.uk).

### **Reducing your charges**

- 1.15. The most effective way to reduce your energy charges is to reduce your consumption by switching off or using more energy efficient appliances. However, there are also other potential opportunities to reduce your distribution charges; for example, it may be beneficial to shift demand or generation to a better time period. Demand use is likely to be cheaper outside the peak periods and generation credits more beneficial during peak periods, although the ability to directly benefit will be linked to the structure of your supply charges.
- 1.16. The calculator mentioned above provides the opportunity to establish a forecast of the change in distribution charges that could be achieved if you are able to change any of the consumption related inputs.

### **Reactive power and reactive power charges**

- 1.17. Reactive power is a separately charged component of connections that are half-hourly metered. Reactive power charges are generally avoidable if 'best practice' design of the properties' electrical installation has been provided in order to maintain a power factor between 0.95 and unity at the Metering Point.

- 1.18. Reactive Power (kVArh) is the difference between working power (active power measured in kW) and total power consumed (apparent power measured in kVA). Essentially it is a measure of how efficiently electrical power is transported through an electrical installation or a Distribution System.
- 1.19. Power flowing with a power factor of unity results in the most efficient loading of the Distribution System. Power flowing with a power factor of less than 0.95 results in much higher losses in the Distribution System, a need to potentially provide higher capacity electrical equipment and consequently a higher bill for you the consumer. A comparatively small improvement in power factor can bring about a significant reduction in losses since losses are proportional to the square of the current.
- 1.20. Different types of electrical equipment require some 'reactive power' in addition to 'active power' in order to work effectively. Electric motors, transformers and fluorescent lighting, for example, may produce poor power factors due to the nature of their inductive load. However, if good design practice is applied then the poor power factor of appliances can be corrected as near as possible to source. Alternatively poor power factor can be corrected centrally near to the meter.
- 1.21. There are many advantages that can be achieved by correcting poor power factor. These include: reduced energy bills through lower reactive charges, lower capacity charges and reduced power consumption and reduced voltage drop in long cable runs.

### Site-specific charges

- 1.22. A site classified as an EHV Property is subject to a locational-based charging methodology for higher voltage network users. The site-specific charges will apply to Customers connected at Extra-High Voltage or connected at High Voltage and metered at an Extra-High Voltage or High Voltage substation.
- 1.23. The site-specific charges reflect the degree to which the local and higher voltage networks have the capacity to serve more demand without the need to upgrade the electricity infrastructure. The conditions for eligibility of generators for credits are specified in the applicable charging methodology. Generators that benefit from an exemption from UoS charges for generation, or that are intermittent in accordance to the definitions in Engineering Recommendation P2/7 and that cannot maintain production for a continuous period of several weeks, are unlikely to be eligible for EHV credits. In any event, eligibility for EHV credits depends on a site-specific assessment of whether the generation can be considered to have a contribution to security of supply under Engineering Recommendation P2/7.

- 1.24. The site-specific charges comprise of the following individual components:

- a) **Fixed charge (pence/MPAN/day)** - This charge recovers operational costs associated with those connection assets that are provided for the 'sole' use of the Customer and a residual amount to ensure recovery of our regulated allowed revenue.
- b) **Capacity charge (pence/kVA/day)** - This charge comprises of the relevant locational cost component assessed by the Host DNO relevant for the Customer's connection, the National Grid Electricity Transmission cost and other business costs.

Capacity charges are levied on the MIC, MEC, and any exceeded capacity. You may wish to review your MIC or MEC periodically to ensure it remains appropriate for your needs as you may be paying for more capacity than you require. If you wish to make changes contact us via the details in paragraph 1.14.

- c) **Super-red unit charge (pence/kWh)** - This charge recovers the relevant locational cost component assessed by the Host DNO relevant for the Customer's connection. The charge is zero or positive for import and zero or negative for export which means you can either reduce your charges by minimising consumption or increasing export at those times. The charge is applied to consumption during the Super-red time period as detailed in Annex 2.

- 1.25. Future charge rates may be affected by consumption during the Super-red time period, therefore reducing consumption in the Super-red time period may be beneficial.
- 1.26. **Reactive Power** – The site-specific charges does not include a separate charge component for any reactive power flows (kVAr) for either demand or generation. However, the charges do reflect the effect on the network of the Customer's power factor, for example, unit charges can increase if your site power factor is poor (lower than 0.95). Improving your site's power factor will also reduce

the maximum demand (kVA) for the same power consumed in kW thus providing scope to reduce your agreed capacity requirements.

## Additional Notes

Domestic Aggregated (related MPAN) and Non-Domestic Aggregated (related MPAN) are supplementary, off-peak, tariffs to their standard, Domestic Aggregated and Non-Domestic Aggregated tariffs, respectively. Related MPAN, off-peak, terms are only available to Metering Points that are already on such terms and where:

- a) the Customer retains the original off-peak equipment and the circuits from which the off-peak supply is taken are separated from all other circuits;
- b) the function of the off-peak equipment is not duplicated by other equipment connected to the other circuits; and
- c) “off-peak equipment” means appliances such as thermal storage heaters, storage water heaters or other equipment as agreed by us

Generally, Domestic DUoS tariffs are available only to premises:

- a) used exclusively as a single private residence; or
- b) comprising more than one private residence where the estimated maximum demand of the supply does not exceed 25 kW

## Appendix 3 – Non-Final Demand Site Certificate

A certificate set out in the form of the example shown below should be submitted to confirm that a site qualifies as a Non-Final Demand Site.

### Non-Final Demand Site Certificate of Compliance

This is to certify that the Metering System listed below qualifies as compliant with the criteria of a Non-Final Demand Site, for the purposes of Use of System charges, and that:

The property is a Single Site at which either or both Electricity Storage and/or Electricity Generation occurs (whether the facility(ies) at the site are operating or being commissioned, repaired, or decommissioned), and that:

- a) has an export Metering Point or Metering System and an import Metering Point or Metering System with associated metering equipment which only measures export from Electricity Storage and/or Electricity Generation and import for or directly relating to Electricity Storage and/or Electricity Generation (and not export from another source and/or import for another activity; and
  - if registered in an MPAS Registration System, is subject to certification from a Supplier Party that the site meets the criteria in paragraph (a) above, which certificate has been provided to the DNO/IDNO Party; or
  - if registered in CMRS, is subject to certification from the Customer (or its CVA Registrant) that the site meets the criteria in paragraph (a) above, which certificate has been provided to the DNO/IDNO Party.

For the purposes of this declaration, the term Non-Final Demand Site has the meaning given to it in the DCUSA.

Metering System Site Address:

Qualifying Import MPAN/MSID(s)

Qualifying Export MPAN/MSID(s)

I declare that I understand the qualification requirements and certify that the above Metering System meets the criteria of a Non-Final Demand Site.

Authorised signatory:

Name and designation:

On behalf of company:

Date:

## Annex 1 - Schedule of Charges for use of the Distribution System by LV and HV Properties in “Eastern Power Networks Area (GSP Group \_A)”

### Southern Electric Power Distribution plc - Effective from 1st April 2027 - Final LV and HV charges in UKPN EPN Area (GSP Group \_A)

Time Bands for LV and HV Properties			
Time periods	Red Time Band	Amber Time Band	Green Time Band
Monday to Friday (Including Bank Holidays) All Year	16:00 - 19:00	07:00 - 16:00 19:00 - 23:00	00:00 - 07:00 23:00 - 24:00
Saturday and Sunday All Year			00:00 - 24:00
Notes	All times are in UK Clock time		

Time Bands for Unmetered Properties			
	Black Time Band	Yellow Time Band	Green Time Band
Monday to Friday (Including Bank Holidays) November to February Inclusive	16:00 - 19:00	07:00 - 16:00 19:00 - 23:00	00:00 - 07:00 23:00 - 24:00
Monday to Friday (Including Bank Holidays) March to October Inclusive		07:00 - 23:00	00:00 - 07:00 23:00 - 24:00
Saturday and Sunday All Year			00:00 - 24:00
Notes	All times are in UK Clock time		

Tariff name	Open LLFCs / DUoS Tariff IDs	PCs	Red/black unit charge p/kWh	Amber/yellow unit charge p/kWh	Green unit charge p/kWh	Fixed charge p/MPAN/day	Capacity charge p/kVA/day	Exceeded capacity charge p/kVA/day	Reactive power charge p/kVArh	Closed LLFCs / DUoS Tariff IDs
Domestic Aggregated or CT with Residual	167, 201-202, 258, 269, 301-302, 495, AA0	0, 1, 2	15.087	2.472	0.333	11.78				
Domestic Aggregated (Related MPAN)		2	15.087	2.472	0.333					
Non-Domestic Aggregated or CT No Residual	A10, A15, A20, A30, A35, A40, A45, A65, A70, A75, A85, A90, R75, AA1	0, 3, 4, 5-8	11.648	1.909	0.257	10.40				

Tariff name	Open LLFCs / DUoS Tariff IDs	PCs	Red/black unit charge p/kWh	Amber/yellow unit charge p/kWh	Green unit charge p/kWh	Fixed charge p/MPAN/day	Capacity charge p/kVA/day	Exceeded capacity charge p/kVA/day	Reactive power charge p/kVAh	Closed LLFCs / DUoS Tariff IDs
Non-Domestic Aggregated or CT Band 1	A11, A16, A21, A31, A36, A41, A46, A66, A71, A76, A86, A91, R76, AA2	0, 3, 4, 5-8	11.648	1.909	0.257	12.37				
Non-Domestic Aggregated or CT Band 2	A12, A17, A22, A32, A37, A42, A47, A67, A72, A77, A87, A92, R77, AA3	0, 3, 4, 5-8	11.648	1.909	0.257	15.67				
Non-Domestic Aggregated or CT Band 3	A13, A18, A23, A33, A38, A43, A48, A68, A73, A78, A88, A93, R78, AA4	0, 3, 4, 5-8	11.648	1.909	0.257	20.93				
Non-Domestic Aggregated or CT Band 4	A14, A19, A24, A34, A39, A44, A49, A69, A74, A79, A89, A94, R79, AA5	0, 3, 4, 5-8	11.648	1.909	0.257	39.74				
Non-Domestic Aggregated (related MPAN)		4	11.648	1.909	0.257					
LV Site Specific No Residual	A05, A50, A60	0	8.529	1.330	0.168	24.89	8.79	8.79	0.427	
LV Site Specific Band 1	A06, A51, A61	0	8.529	1.330	0.168	86.99	8.79	8.79	0.427	
LV Site Specific Band 2	A07, A52, A62	0	8.529	1.330	0.168	123.11	8.79	8.79	0.427	
LV Site Specific Band 3	A08, A53, A63	0	8.529	1.330	0.168	173.53	8.79	8.79	0.427	
LV Site Specific Band 4	A09, A54, A64	0	8.529	1.330	0.168	370.11	8.79	8.79	0.427	
LV Sub Site Specific No Residual	A95	0	5.428	0.778	0.087	20.94	6.38	6.38	0.250	
LV Sub Site Specific Band 1	A96	0	5.428	0.778	0.087	83.05	6.38	6.38	0.250	
LV Sub Site Specific Band 2	A97	0	5.428	0.778	0.087	119.16	6.38	6.38	0.250	

Tariff name	Open LLFCs / DUoS Tariff IDs	PCs	Red/black unit charge p/kWh	Amber/yellow unit charge p/kWh	Green unit charge p/kWh	Fixed charge p/MPAN/day	Capacity charge p/kVA/day	Exceeded capacity charge p/kVA/day	Reactive power charge p/kVAh	Closed LLFCs / DUoS Tariff IDs
LV Sub Site Specific Band 3	A98	0	5.428	0.778	0.087	169.58	6.38	6.38	0.250	
LV Sub Site Specific Band 4	A99	0	5.428	0.778	0.087	366.16	6.38	6.38	0.250	
HV Site Specific No Residual	A25, A55, A80	0	4.655	0.631	0.067	222.02	5.60	5.60	0.202	
HV Site Specific Band 1	A26, A56, A81	0	4.655	0.631	0.067	765.86	5.60	5.60	0.202	
HV Site Specific Band 2	A27, A57, A82	0	4.655	0.631	0.067	1382.89	5.60	5.60	0.202	
HV Site Specific Band 3	A28, A58, A83	0	4.655	0.631	0.067	2272.02	5.60	5.60	0.202	
HV Site Specific Band 4	A29, A59, A84	0	4.655	0.631	0.067	6205.46	5.60	5.60	0.202	
Unmetered Supplies	207, 275-278, 530-534, A00	0, 1 or 8	44.435	4.578	2.654					
LV Generation Aggregated	961, A01	0 or 8	-8.760	-1.435	-0.194	0.00				
LV Sub Generation Aggregated		0	-6.988	-1.106	-0.143	0.00				
LV Generation Site Specific	9, 307, A02	0	-8.760	-1.435	-0.194	0.00			0.500	
LV Generation Site Specific no RP charge	13-14, A03	0	-8.760	-1.435	-0.194	0.00				
LV Sub Generation Site Specific	10-11	0	-6.988	-1.106	-0.143	0.00			0.354	
LV Sub Generation Site Specific no RP charge	75-76	0	-6.988	-1.106	-0.143	0.00				
HV Generation Site Specific	12, 308	0	-5.127	-0.735	-0.082	15.58			0.299	
HV Generation Site Specific no RP charge	77-78	0	-5.127	-0.735	-0.082	15.58				

## Annex 1 - Schedule of Charges for use of the Distribution System by LV and HV Properties in “NGED East Midlands Area (GSP Group \_B)”

### Southern Electric Power Distribution plc - Effective from 1st April 2027 - Final LV and HV charges in NGED EM Area (GSP Group \_B)

Time Bands for LV and HV Properties			
Time periods	Red Time Band	Amber Time Band	Green Time Band
Monday to Friday (Including Bank Holidays) All Year	16:00 to 19:00	07:30 to 16:00 19:00 to 21:00	00:00 to 07:30 21:00 to 24:00
Saturday and Sunday All Year			00:00 to 24:00
Notes	All the above times are in UK Clock time		

Time Bands for Unmetered Properties			
	Black Time Band	Yellow Time Band	Green Time Band
Monday to Friday (Including Bank Holidays) Nov to Feb Inclusive	16:00 to 19:00	07:30 to 16:00 19:00 to 21:00	00:00 to 07:30 21:00 to 24:00
Monday to Friday (Including Bank Holidays) Mar to Oct Inclusive		07:30 to 21:00	00:00 to 07:30 21:00 to 24:00
Saturday and Sunday All year			00:00 to 24:00
Notes	All the above times are in UK Clock time		

Tariff name	Open LLFCs / DUoS Tariff IDs	PCs	Red/black unit charge p/kWh	Amber/yellow unit charge p/kWh	Green unit charge p/kWh	Fixed charge p/MPAN/day	Capacity charge p/kVA/day	Exceeded capacity charge p/kVA/day	Reactive power charge p/kVAh	Closed LLFCs / DUoS Tariff IDs
Domestic Aggregated or CT with Residual	169, 279-280, 311-312, 461-462, 497, BA0	0, 1, 2	12.755	1.521	0.125	12.28				
Domestic Aggregated (Related MPAN)		2	12.755	1.521	0.125					
Non-Domestic Aggregated or CT No Residual	B05, B10, B15, B35, B40, B45, B55, B60, B70, B75, B80, B85, BA1	0, 3, 4, 5-8	12.349	1.473	0.121	12.13				
Non-Domestic Aggregated or CT Band 1	B06, B11, B16, B36, B41, B46, B56, B61, B71, B76, B81, B86, BA2	0, 3, 4, 5-8	12.349	1.473	0.121	15.42				

Tariff name	Open LLFCs / DUoS Tariff IDs	PCs	Red/black unit charge p/kWh	Amber/yellow unit charge p/kWh	Green unit charge p/kWh	Fixed charge p/MPAN/day	Capacity charge p/kVA/day	Exceeded capacity charge p/kVA/day	Reactive power charge p/kVAh	Closed LLFCs / DUoS Tariff IDs
Non-Domestic Aggregated or CT Band 2	B07, B12, B17, B37, B42, B47, B57, B62, B72, B77, B82, B87, BA3	0, 3, 4, 5-8	12.349	1.473	0.121	24.53				
Non-Domestic Aggregated or CT Band 3	B08, B13, B18, B38, B43, B48, B58, B63, B73, B78, B83, B88, BA4	0, 3, 4, 5-8	12.349	1.473	0.121	39.34				
Non-Domestic Aggregated or CT Band 4	B09, B14, B19, B39, B44, B49, B59, B64, B74, B79, B84, B89, BA5	0, 3, 4, 5-8	12.349	1.473	0.121	83.58				
Non-Domestic Aggregated (related MPAN)		4	12.349	1.473	0.121					
LV Site Specific No Residual	B20, B30	0	8.368	0.935	0.072	14.27	7.88	7.88	0.247	
LV Site Specific Band 1	B21, B31	0	8.368	0.935	0.072	139.65	7.88	7.88	0.247	
LV Site Specific Band 2	B22, B32	0	8.368	0.935	0.072	226.69	7.88	7.88	0.247	
LV Site Specific Band 3	B23, B33	0	8.368	0.935	0.072	356.10	7.88	7.88	0.247	
LV Site Specific Band 4	B24, B34	0	8.368	0.935	0.072	701.34	7.88	7.88	0.247	
LV Sub Site Specific No Residual	B65	0	5.507	0.524	0.033	11.14	7.62	7.62	0.156	
LV Sub Site Specific Band 1	B66	0	5.507	0.524	0.033	136.52	7.62	7.62	0.156	
LV Sub Site Specific Band 2	B67	0	5.507	0.524	0.033	223.56	7.62	7.62	0.156	
LV Sub Site Specific Band 3	B68	0	5.507	0.524	0.033	352.97	7.62	7.62	0.156	

Tariff name	Open LLFCs / DUoS Tariff IDs	PCs	Red/black unit charge p/kWh	Amber/yellow unit charge p/kWh	Green unit charge p/kWh	Fixed charge p/MPAN/day	Capacity charge p/kVA/day	Exceeded capacity charge p/kVA/day	Reactive power charge p/kVArh	Closed LLFCs / DUoS Tariff IDs
LV Sub Site Specific Band 4	B69	0	5.507	0.524	0.033	698.21	7.62	7.62	0.156	
HV Site Specific No Residual	B25, B50	0	3.125	0.233	0.009	102.86	8.83	8.83	0.077	
HV Site Specific Band 1	B26, B51	0	3.125	0.233	0.009	952.43	8.83	8.83	0.077	
HV Site Specific Band 2	B27, B52	0	3.125	0.233	0.009	2585.12	8.83	8.83	0.077	
HV Site Specific Band 3	B28, B53	0	3.125	0.233	0.009	4700.06	8.83	8.83	0.077	
HV Site Specific Band 4	B29, B54	0	3.125	0.233	0.009	11785.66	8.83	8.83	0.077	
Unmetered Supplies	286-289, 535-539, B00	0, 1 or 8	39.633	2.960	1.656					
LV Generation Aggregated	965, B01	0 or 8	-8.040	-0.959	-0.079	0.00				
LV Sub Generation Aggregated		0	-6.716	-0.769	-0.061	0.00				
LV Generation Site Specific	15, 317, 512, B02	0	-8.040	-0.959	-0.079	0.00			0.280	
LV Generation Site Specific no RP charge	19-20, 513, B03	0	-8.040	-0.959	-0.079	0.00				
LV Sub Generation Site Specific	16-17	0	-6.716	-0.769	-0.061	0.00			0.209	
LV Sub Generation Site Specific no RP charge	89, 132	0	-6.716	-0.769	-0.061	0.00				
HV Generation Site Specific	18, 318	0	-4.189	-0.398	-0.025	64.37			0.173	
HV Generation Site Specific no RP charge	137, 158	0	-4.189	-0.398	-0.025	64.37				

## Annex 1 - Schedule of Charges for use of the Distribution System by LV and HV Properties in “London Power Networks Area (GSP Group \_C)”

Southern Electric Power Distribution plc - Effective from 1st April 2027 - Final LV and HV charges in UKPN LPN Area (GSP Group \_C)

Time Bands for LV and HV Properties			
Time periods	Red Time Band	Amber Time Band	Green Time Band
Monday to Friday (Including Bank Holidays) All Year	11:00 - 14:00 16:00 - 19:00	07:00 - 11:00 14:00 - 16:00 19:00 - 23:00	00:00 - 07:00 23:00 - 24:00
Saturday and Sunday All Year			00:00 - 24:00
Notes	All times are in UK Clock time		

Time Bands for Unmetered Properties			
	Black Time Band	Yellow Time Band	Green Time Band
Monday to Friday (Including Bank Holidays) June to August Inclusive	11:00 - 14:00	07:00 - 11:00 14:00 - 23:00	00:00 - 07:00 23:00 - 24:00
Monday to Friday (Including Bank Holidays) November to February Inclusive	16:00 - 19:00	07:00 - 16:00 19:00 - 23:00	00:00 - 07:00 23:00 - 24:00
Monday to Friday (Including Bank Holidays) March, April, May and September, October		07:00 - 23:00	00:00 - 07:00 23:00 - 24:00
Saturday and Sunday All year			00:00 - 24:00
Notes	All times are in UK Clock time		

Tariff name	Open LLFCs / DUoS Tariff IDs	PCs	Red/black unit charge p/kWh	Amber/yellow unit charge p/kWh	Green unit charge p/kWh	Fixed charge p/MPAN/day	Capacity charge p/kVA/day	Exceeded capacity charge p/kVA/day	Reactive power charge p/kVArh	Closed LLFCs / DUoS Tariff IDs
Domestic Aggregated or CT with Residual	171, 191-192, 221-222, 321-322, 417-418, 506, 508, CA0	0, 1, 2	12.197	1.243	0.000	0.00				
Domestic Aggregated (Related MPAN)		2	12.414	1.460	0.108					

Tariff name	Open LLFCs / DUoS Tariff IDs	PCs	Red/black unit charge p/kWh	Amber/yellow unit charge p/kWh	Green unit charge p/kWh	Fixed charge p/MPAN/day	Capacity charge p/kVA/day	Exceeded capacity charge p/kVA/day	Reactive power charge p/kVArh	Closed LLFCs / DUoS Tariff IDs
Non-Domestic Aggregated or CT No Residual	C05, C10, C20, C30, C35, C40, C50, C60, C65, C70, C80, C85, C90, C95, R20, R25, R30, R35, CA1	0, 3, 4, 5-8	9.611	1.130	0.083	5.91				
Non-Domestic Aggregated or CT Band 1	C06, C11, C21, C31, C36, C41, C51, C61, C66, C71, C81, C86, C91, C96, R21, R26, R31, R36, CA2	0, 3, 4, 5-8	9.491	1.010	0.000	0.00				
Non-Domestic Aggregated or CT Band 2	C07, C12, C22, C32, C37, C42, C52, C62, C67, C72, C82, C87, C92, C97, R22, R27, R32, R37, CA3	0, 3, 4, 5-8	8.644	0.164	0.000	0.00				
Non-Domestic Aggregated or CT Band 3	C08, C13, C23, C33, C38, C43, C53, C63, C68, C73, C83, C88, C93, C98, R23, R28, R33, R38, CA4	0, 3, 4, 5-8	8.334	0.000	0.000	0.00				
Non-Domestic Aggregated or CT Band 4	C09, C14, C24, C34, C39, C44, C54, C64, C69, C74, C84, C89, C94, C99, R24, R29, R34, R39, CA5	0, 3, 4, 5-8	7.932	0.000	0.000	0.00				
Non-Domestic Aggregated (related MPAN)		4	9.611	1.130	0.083					
LV Site Specific No Residual	C15, C25, C55, R00	0	7.639	0.922	0.062	14.51	8.26	8.26	0.588	

Tariff name	Open LLFCs / DUoS Tariff IDs	PCs	Red/black unit charge p/kWh	Amber/yellow unit charge p/kWh	Green unit charge p/kWh	Fixed charge p/MPAN/day	Capacity charge p/kVA/day	Exceeded capacity charge p/kVA/day	Reactive power charge p/kVAh	Closed LLFCs / DUoS Tariff IDs
LV Site Specific Band 1	C16, C26, C56, R01	0	4.886	0.322	0.030	2.30	8.26	8.26	0.588	
LV Site Specific Band 2	C17, C27, C57, R02	0	4.821	0.322	0.030	2.30	8.26	8.26	0.588	
LV Site Specific Band 3	C18, C28, C58, R03	0	4.763	0.322	0.030	2.30	8.26	8.26	0.588	
LV Site Specific Band 4	C19, C29, C59, R04	0	4.692	0.322	0.030	2.30	8.26	8.26	0.588	
LV Sub Site Specific No Residual	R10, R15	0	4.691	0.599	0.033	12.21	10.38	10.38	0.348	
LV Sub Site Specific Band 1	R11, R16	0	1.938	0.000	0.000	0.00	10.38	10.38	0.348	
LV Sub Site Specific Band 2	R12, R17	0	1.873	0.000	0.000	0.00	10.38	10.38	0.348	
LV Sub Site Specific Band 3	R13, R18	0	1.815	0.000	0.000	0.00	10.38	10.38	0.348	
LV Sub Site Specific Band 4	R14, R19	0	1.743	0.000	0.000	0.00	10.38	10.38	0.348	
HV Site Specific No Residual	C45, C75, R05	0	3.488	0.446	0.026	129.42	10.65	10.65	0.271	
HV Site Specific Band 1	C46, C76, R06	0	0.420	0.000	0.000	0.00	10.65	10.65	0.271	
HV Site Specific Band 2	C47, C77, R07	0	0.223	0.000	0.000	0.00	10.65	10.65	0.271	
HV Site Specific Band 3	C48, C78, R08	0	0.305	0.000	0.000	0.00	10.65	10.65	0.271	
HV Site Specific Band 4	C49, C79, R09	0	0.240	0.000	0.000	0.00	10.65	10.65	0.271	
Unmetered Supplies	227, 424-427, 540-544, C02	0, 1 or 8	40.972	3.346	0.471					
LV Generation Aggregated	967, C03	0 or 8	-7.828	-0.921	-0.068	0.00				

Tariff name	Open LLFCs / DUoS Tariff IDs	PCs	Red/black unit charge p/kWh	Amber/yellow unit charge p/kWh	Green unit charge p/kWh	Fixed charge p/MPAN/day	Capacity charge p/kVA/day	Exceeded capacity charge p/kVA/day	Reactive power charge p/kVArh	Closed LLFCs / DUoS Tariff IDs
LV Sub Generation Aggregated		0	-6.433	-0.769	-0.054	0.00				
LV Generation Site Specific	21, 327, C04, R80	0	-7.828	-0.921	-0.068	0.00			0.550	
LV Generation Site Specific no RP charge	25-26, 228, 230, R81	0	-7.828	-0.921	-0.068	0.00				
LV Sub Generation Site Specific	22-23	0	-6.433	-0.769	-0.054	0.00			0.433	
LV Sub Generation Site Specific no RP charge	159, 208, 216-217	0	-6.433	-0.769	-0.054	0.00				
HV Generation Site Specific	24, 328, C00	0	-4.179	-0.534	-0.029	9.08			0.382	
HV Generation Site Specific no RP charge	214-215, 218-219	0	-4.179	-0.534	-0.029	9.08				

## Annex 1 - Schedule of Charges for use of the Distribution System by LV and HV Properties in "SP Manweb Area (GSP Group \_D)"

### Southern Electric Power Distribution plc - Effective from 1st April 2027 - Final LV and HV charges in SP Manweb Area (GSP Group \_D)

Time Bands for LV and HV Properties			
Time periods	Red Time Band	Amber Time Band	Green Time Band
Monday to Friday (Including Bank Holidays) All Year	16.30 - 19.30	08.00 - 16.30 19.30 - 22.30	00.00 - 08.00 22.30 - 00.00
Saturday and Sunday All Year		16.00 - 20.00	00.00 - 16.00 20.00 - 00.00
Notes	All the above times are in UK Clock time		

Time Bands for Unmetered Properties			
	Black Time Band	Yellow Time Band	Green Time Band
Monday to Friday (Including Bank Holidays) June to August Inclusive		08.00 - 22.30	00.00 - 08.00 22.30 - 00.00
Monday to Friday (Including Bank Holidays) November to February Inclusive	16.30 - 19.30	08.00 - 16.30 19.30 - 22.30	00.00 - 08.00 22.30 - 00.00
Monday to Friday (Including Bank Holidays) March, April, May and September, October		08.00 - 22.30	00.00 - 08.00 22.30 - 00.00
Saturday and Sunday All year		16.00 - 20.00	00:00 - 16:00 20:00 - 00:00
Notes	All the above times are in UK Clock time		

Tariff name	Open LLFCs / DUoS Tariff IDs	PCs	Red/black unit charge p/kWh	Amber/yellow unit charge p/kWh	Green unit charge p/kWh	Fixed charge p/MPAN/day	Capacity charge p/kVA/day	Exceeded capacity charge p/kVA/day	Reactive power charge p/kVAh	Closed LLFCs / DUoS Tariff IDs
Domestic Aggregated or CT with Residual	173, 331-332, DA0	0, 1, 2	15.969	3.454	0.464	25.01				
Domestic Aggregated (Related MPAN)		2	15.969	3.454	0.464					
Non-Domestic Aggregated or CT No Residual	D45, D15, D20, D25, D35, DA1	0, 3, 4, 5- 8	16.630	3.597	0.483	7.08				
Non-Domestic Aggregated or CT Band 1	D46, D16, D21, D26, D36, DA2	0, 3, 4, 5- 8	16.630	3.597	0.483	31.10				
Non-Domestic Aggregated or CT Band 2	D47, D17, D22, D27, D37, DA3	0, 3, 4, 5- 8	16.630	3.597	0.483	54.62				

Tariff name	Open LLFCs / DUoS Tariff IDs	PCs	Red/black unit charge p/kWh	Amber/yellow unit charge p/kWh	Green unit charge p/kWh	Fixed charge p/MPAN/day	Capacity charge p/kVA/day	Exceeded capacity charge p/kVA/day	Reactive power charge p/kVArh	Closed LLFCs / DUoS Tariff IDs
Non-Domestic Aggregated or CT Band 3	D48, D18, D23, D28, D38, DA4	0, 3, 4, 5-8	16.630	3.597	0.483	107.32				
Non-Domestic Aggregated or CT Band 4	D49, D19, D24, D29, D39, DA5	0, 3, 4, 5-8	16.630	3.597	0.483	297.35				
Non-Domestic Aggregated (related MPAN)		4	16.630	3.597	0.483					
LV Site Specific No Residual	D10	0	12.053	2.374	0.307	23.02	6.92	6.92	0.647	
LV Site Specific Band 1	D11	0	12.053	2.374	0.307	583.60	6.92	6.92	0.647	
LV Site Specific Band 2	D12	0	12.053	2.374	0.307	1081.44	6.92	6.92	0.647	
LV Site Specific Band 3	D13	0	12.053	2.374	0.307	1700.70	6.92	6.92	0.647	
LV Site Specific Band 4	D14	0	12.053	2.374	0.307	3884.98	6.92	6.92	0.647	
LV Sub Site Specific No Residual	D40	0	8.738	1.391	0.161	8.12	10.74	10.74	0.364	
LV Sub Site Specific Band 1	D41	0	8.738	1.391	0.161	568.71	10.74	10.74	0.364	
LV Sub Site Specific Band 2	D42	0	8.738	1.391	0.161	1066.55	10.74	10.74	0.364	
LV Sub Site Specific Band 3	D43	0	8.738	1.391	0.161	1685.81	10.74	10.74	0.364	
LV Sub Site Specific Band 4	D44	0	8.738	1.391	0.161	3870.09	10.74	10.74	0.364	
HV Site Specific No Residual	D05, D30	0	6.875	1.004	0.104	122.99	9.98	9.98	0.261	
HV Site Specific Band 1	D06, D31	0	6.875	1.004	0.104	3164.03	9.98	9.98	0.261	

Tariff name	Open LLFCs / DUoS Tariff IDs	PCs	Red/black unit charge p/kWh	Amber/yellow unit charge p/kWh	Green unit charge p/kWh	Fixed charge p/MPAN/day	Capacity charge p/kVA/day	Exceeded capacity charge p/kVA/day	Reactive power charge p/kVArh	Closed LLFCs / DUoS Tariff IDs
HV Site Specific Band 2	D07, D32	0	6.875	1.004	0.104	9369.42	9.98	9.98	0.261	
HV Site Specific Band 3	D08, D33	0	6.875	1.004	0.104	20533.79	9.98	9.98	0.261	
HV Site Specific Band 4	D09, D34	0	6.875	1.004	0.104	39330.22	9.98	9.98	0.261	
Unmetered Supplies	545-549, D00	0, 1 or 8	35.737	5.570	3.017					
LV Generation Aggregated	969, D01	0 or 8	-11.134	-2.408	-0.324	0.00				
LV Sub Generation Aggregated		0	-9.503	-1.939	-0.255	0.00				
LV Generation Site Specific	27, 337, D02	0	-11.134	-2.408	-0.324	0.00			0.610	
LV Generation Site Specific no RP charge	31-32, D03	0	-11.134	-2.408	-0.324	0.00				
LV Sub Generation Site Specific	28-29	0	-9.503	-1.939	-0.255	0.00			0.526	
LV Sub Generation Site Specific no RP charge	231-232	0	-9.503	-1.939	-0.255	0.00				
HV Generation Site Specific	30, 338	0	-7.057	-1.123	-0.130	89.81			0.446	
HV Generation Site Specific no RP charge	233-234	0	-7.057	-1.123	-0.130	89.81				

## Annex 1 - Schedule of Charges for use of the Distribution System by LV and HV Properties in “NGED West Midlands Area (GSP Group \_E)”

### Southern Electric Power Distribution plc - Effective from 1st April 2027 - Final LV and HV charges in NGED West Midlands Area (GSP Group \_E)

Time Bands for LV and HV Properties			
Time periods	Red Time Band	Amber Time Band	Green Time Band
Monday to Friday (Including Bank Holidays) All Year	16:00 - 19:00	07:30 - 16:00 19:00 - 21:00	00:00 - 07:30 21:00 - 24:00
Saturday and Sunday All Year			00:00 - 24:00
Notes	All the above times are in UK Clock time		

Time Bands for Unmetered Properties			
	Black Time Band	Yellow Time Band	Green Time Band
Monday to Friday (Including Bank Holidays) Nov to Feb Inclusive	16:00 - 19:00	07:30 - 16:00 19:00 - 21:00	00:00 - 07:30 21:00 - 24:00
Monday to Friday (Including Bank Holidays) Mar to Oct Inclusive		07:30 - 21:00	00:00 - 07:30 21:00 - 24:00
Saturday and Sunday All Year			00:00 - 24:00
Notes	All the above times are in UK Clock time		

Tariff name	Open LLFCs / DUoS Tariff IDs	PCs	Red/black unit charge p/kWh	Amber/yellow unit charge p/kWh	Green unit charge p/kWh	Fixed charge p/MPAN/day	Capacity charge p/kVA/day	Exceeded capacity charge p/kVA/day	Reactive power charge p/kVArh	Closed LLFCs / DUoS Tariff IDs
Domestic Aggregated or CT with Residual	175, 341-342, EA0	0, 1, 2	12.080	1.519	0.188	16.78				
Domestic Aggregated (Related MPAN)		2	12.080	1.519	0.188					
Non-Domestic Aggregated or CT No Residual	E10, E15, E20, E30, E40, EA1	0, 3, 4, 5-8	10.915	1.372	0.170	15.46				
Non-Domestic Aggregated or CT Band 1	E11, E16, E21, E31, E41, EA2	0, 3, 4, 5-8	10.915	1.372	0.170	19.80				
Non-Domestic Aggregated or CT Band 2	E12, E17, E22, E32, E42, EA3	0, 3, 4, 5-8	10.915	1.372	0.170	32.24				
Non-Domestic Aggregated or CT Band 3	E13, E18, E23, E33, E43, EA4	0, 3, 4, 5-8	10.915	1.372	0.170	51.59				

Tariff name	Open LLFCs / DUoS Tariff IDs	PCs	Red/black unit charge p/kWh	Amber/yellow unit charge p/kWh	Green unit charge p/kWh	Fixed charge p/MPAN/day	Capacity charge p/kVA/day	Exceeded capacity charge p/kVA/day	Reactive power charge p/kVArh	Closed LLFCs / DUoS Tariff IDs
Non-Domestic Aggregated or CT Band 4	E14, E19, E24, E34, E44, EA5	0, 3, 4, 5-8	10.915	1.372	0.170	108.96				
Non-Domestic Aggregated (related MPAN)		4	10.915	1.372	0.170					
LV Site Specific No Residual	E05	0	6.971	0.866	0.096	15.46	11.21	11.21	0.152	
LV Site Specific Band 1	E06	0	6.971	0.866	0.096	172.59	11.21	11.21	0.152	
LV Site Specific Band 2	E07	0	6.971	0.866	0.096	294.58	11.21	11.21	0.152	
LV Site Specific Band 3	E08	0	6.971	0.866	0.096	454.06	11.21	11.21	0.152	
LV Site Specific Band 4	E09	0	6.971	0.866	0.096	809.60	11.21	11.21	0.152	
LV Sub Site Specific No Residual	E35	0	3.827	0.459	0.032	12.07	9.62	9.62	0.082	
LV Sub Site Specific Band 1	E36	0	3.827	0.459	0.032	169.20	9.62	9.62	0.082	
LV Sub Site Specific Band 2	E37	0	3.827	0.459	0.032	291.19	9.62	9.62	0.082	
LV Sub Site Specific Band 3	E38	0	3.827	0.459	0.032	450.67	9.62	9.62	0.082	
LV Sub Site Specific Band 4	E39	0	3.827	0.459	0.032	806.21	9.62	9.62	0.082	
HV Site Specific No Residual	E25	0	1.878	0.212	0.011	111.38	9.69	9.69	0.036	
HV Site Specific Band 1	E26	0	1.878	0.212	0.011	1068.39	9.69	9.69	0.036	
HV Site Specific Band 2	E27	0	1.878	0.212	0.011	2987.51	9.69	9.69	0.036	

Tariff name	Open LLFCs / DUoS Tariff IDs	PCs	Red/black unit charge p/kWh	Amber/yellow unit charge p/kWh	Green unit charge p/kWh	Fixed charge p/MPAN/day	Capacity charge p/kVA/day	Exceeded capacity charge p/kVA/day	Reactive power charge p/kVAh	Closed LLFCs / DUoS Tariff IDs
HV Site Specific Band 3	E28	0	1.878	0.212	0.011	5842.58	9.69	9.69	0.036	
HV Site Specific Band 4	E29	0	1.878	0.212	0.011	13110.32	9.69	9.69	0.036	
Unmetered Supplies	550-554, E00	0, 1 or 8	43.452	3.340	1.994					
LV Generation Aggregated	973, E01	0 or 8	-7.505	-0.944	-0.117	0.00				
LV Sub Generation Aggregated		0	-5.915	-0.738	-0.085	0.00				
LV Generation Site Specific	33, 347, E02	0	-7.505	-0.944	-0.117	0.00			0.209	
LV Generation Site Specific no RP charge	37-38, E03	0	-7.505	-0.944	-0.117	0.00				
LV Sub Generation Site Specific	34-35	0	-5.915	-0.738	-0.085	0.00			0.140	
LV Sub Generation Site Specific no RP charge	235, 237	0	-5.915	-0.738	-0.085	0.00				
HV Generation Site Specific	36, 348	0	-2.889	-0.346	-0.024	69.71			0.110	
HV Generation Site Specific no RP charge	238-239	0	-2.889	-0.346	-0.024	69.71				

## Annex 1 - Schedule of Charges for use of the Distribution System by LV and HV Properties in “Northern Powergrid (Northeast) Area (GSP Group \_F)”

Southern Electric Power Distribution plc - Effective from 1st April 2027 - Final LV and HV charges in NPG Northeast Area (GSP Group \_F)

Time Bands for LV and HV Properties			
Time periods	Red Time Band	Amber Time Band	Green Time Band
Monday to Friday (Including Bank Holidays) All Year	16:00 to 19:30	08:00 to 16:00 19:30 to 22:00	00:00 to 08:00 22:00 to 24:00
Saturday and Sunday All Year			00:00 to 24:00
Notes	All the above times are in UK Clock time		

Time Bands for Unmetered Properties			
	Black Time Band	Yellow Time Band	Green Time Band
Monday to Friday (Including Bank Holidays) November to February Inclusive	16:00 to 19:30	08:00 to 16:00 19:30 to 22:00	00:00 to 08:00 22:00 to 24:00
Monday to Friday (Including Bank Holidays) April to October Inclusive and March		08:00 to 22:00	00:00 to 08:00 22:00 to 24:00
Saturday and Sunday All Year			00:00 to 24:00
Notes	All the above times are in UK Clock time		

Tariff name	Open LLFCs / DUoS Tariff IDs	PCs	Red/black unit charge p/kWh	Amber/yellow unit charge p/kWh	Green unit charge p/kWh	Fixed charge p/MPAN/day	Capacity charge p/kVA/day	Exceeded capacity charge p/kVA/day	Reactive power charge p/kVArh	Closed LLFCs / DUoS Tariff IDs
Domestic Aggregated or CT with Residual	177, 179, 251- 252, 351-352, 428-429, 514, 751-752, FA3, SA0	0, 1, 2	11.471	1.853	0.314	22.05				
Domestic Aggregated (Related MPAN)		2	11.471	1.853	0.314					
Non-Domestic Aggregated or CT No Residual	F05, F15, F20, F25, F35, F45, F50, F55, F65, F70, F75, F80, F85, R40, S05, S15, S20, S25, S35, FA4, SA1	0, 3, 4, 5- 8	12.211	1.973	0.334	14.72				

Tariff name	Open LLFCs / DUoS Tariff IDs	PCs	Red/black unit charge p/kWh	Amber/yellow unit charge p/kWh	Green unit charge p/kWh	Fixed charge p/MPAN/day	Capacity charge p/kVA/day	Exceeded capacity charge p/kVA/day	Reactive power charge p/kVArh	Closed LLFCs / DUoS Tariff IDs
Non-Domestic Aggregated or CT Band 1	F06, F16, F21, F26, F36, F46, F51, F56, F66, F71, F76, F81, F86, R41, S06, S16, S21, S26, S36, FA5, SA2	0, 3, 4, 5-8	12.211	1.973	0.334	21.28				
Non-Domestic Aggregated or CT Band 2	F07, F17, F22, F27, F37, F47, F52, F57, F67, F72, F77, F82, F87, R42, S07, S17, S22, S27, S37, FA6, SA3	0, 3, 4, 5-8	12.211	1.973	0.334	31.67				
Non-Domestic Aggregated or CT Band 3	F08, F18, F23, F28, F38, F48, F53, F58, F68, F73, F78, F83, F88, R43, S08, S18, S23, S28, S38, FA7, SA4	0, 3, 4, 5-8	12.211	1.973	0.334	50.90				
Non-Domestic Aggregated or CT Band 4	F09, F19, F24, F29, F39, F49, F54, F59, F69, F74, F79, F84, F89, R44, S09, S19, S24, S29, S39, FA8, SA5	0, 3, 4, 5-8	12.211	1.973	0.334	112.71				
Non-Domestic Aggregated (related MPAN)		4	12.211	1.973	0.334					
LV Site Specific No Residual	F10, F40, F90, S10	0	8.542	1.324	0.227	14.96	5.65	5.65	0.153	
LV Site Specific Band 1	F11, F41, F91, S11	0	8.542	1.324	0.227	177.95	5.65	5.65	0.153	
LV Site Specific Band 2	F12, F42, F92, S12	0	8.542	1.324	0.227	364.33	5.65	5.65	0.153	
LV Site Specific Band 3	F13, F43, F93, S13	0	8.542	1.324	0.227	583.83	5.65	5.65	0.153	

Tariff name	Open LLFCs / DUoS Tariff IDs	PCs	Red/black unit charge p/kWh	Amber/yellow unit charge p/kWh	Green unit charge p/kWh	Fixed charge p/MPAN/day	Capacity charge p/kVA/day	Exceeded capacity charge p/kVA/day	Reactive power charge p/kVAh	Closed LLFCs / DUoS Tariff IDs
LV Site Specific Band 4	F14, F44, F94, S14	0	8.542	1.324	0.227	1505.85	5.65	5.65	0.153	
LV Sub Site Specific No Residual	S00	0	4.822	0.659	0.119	14.96	5.29	5.29	0.082	
LV Sub Site Specific Band 1	S01	0	4.822	0.659	0.119	177.95	5.29	5.29	0.082	
LV Sub Site Specific Band 2	S02	0	4.822	0.659	0.119	364.33	5.29	5.29	0.082	
LV Sub Site Specific Band 3	S03	0	4.822	0.659	0.119	583.83	5.29	5.29	0.082	
LV Sub Site Specific Band 4	S04	0	4.822	0.659	0.119	1505.85	5.29	5.29	0.082	
HV Site Specific No Residual	F30, F60, F95, S30	0	3.558	0.432	0.081	310.63	5.95	5.95	0.059	
HV Site Specific Band 1	F31, F61, F96, S31	0	3.558	0.432	0.081	1688.73	5.95	5.95	0.059	
HV Site Specific Band 2	F32, F62, F97, S32	0	3.558	0.432	0.081	3689.89	5.95	5.95	0.059	
HV Site Specific Band 3	F33, F63, F98, S33	0	3.558	0.432	0.081	6682.78	5.95	5.95	0.059	
HV Site Specific Band 4	F34, F64, F99, S34	0	3.558	0.432	0.081	16390.26	5.95	5.95	0.059	
Unmetered Supplies	257, 435-438, 555-559, 760-764, F00	0, 1 or 8	32.941	2.258	1.041					
LV Generation Aggregated	975, 990, F01	0 or 8	-7.719	-1.247	-0.211					
LV Sub Generation Aggregated		0	-6.500	-1.026	-0.175					
LV Generation Site Specific	39, 357, F02, FA1	0	-7.719	-1.247	-0.211				0.122	

Tariff name	Open LLFCs / DUoS Tariff IDs	PCs	Red/black unit charge p/kWh	Amber/yellow unit charge p/kWh	Green unit charge p/kWh	Fixed charge p/MPAN/day	Capacity charge p/kVA/day	Exceeded capacity charge p/kVA/day	Reactive power charge p/kVArh	Closed LLFCs / DUoS Tariff IDs
LV Generation Site Specific no RP charge	43-44, 244-245, F03, FA2	0	-7.719	-1.247	-0.211					
LV Sub Generation Site Specific	40-41	0	-6.500	-1.026	-0.175				0.114	
LV Sub Generation Site Specific no RP charge	240-241	0	-6.500	-1.026	-0.175					
HV Generation Site Specific	42, 358, 757-758, F04	0	-4.059	-0.555	-0.100	69.30			0.101	
HV Generation Site Specific no RP charge	242-243, 246-247	0	-4.059	-0.555	-0.100	69.30				

## Annex 1 - Schedule of Charges for use of the Distribution System by LV and HV Properties in “SP Electricity North West Area (GSP Group \_G)”

### Southern Electric Power Distribution plc - Effective from 1st April 2027 - Final LV and HV charges in SP Electricity North West Area (GSP Group \_G)

Time Bands for LV and HV Properties			
Time periods	Red Time Band	Amber Time Band	Green Time Band
Monday to Friday (Including Bank Holidays) All Year	16:00 - 19:00	09:00 - 16:00 19:00 - 20:30	00.00 - 09.00 20.30 - 24.00
Saturday and Sunday All Year		16:00 - 19:00	00.00 - 16.00 19.00 - 24.00
Notes	All the above times are in UK Clock time		

Time Bands for Unmetered Properties			
	Black Time Band	Yellow Time Band	Green Time Band
Monday to Friday (Including Bank Holidays) March to October Inclusive		09.00 - 20.30	00.00 - 09.00 20.30 - 24.00
Monday to Friday (Including Bank Holidays) November to February Inclusive	16:00 - 19:00	09:00 - 16.00 19.00 - 20.30	00.00 - 09.00 20.30 - 24.00
Saturday and Sunday All Year		16:00 - 19:00	00.00 - 16.00 19.00 - 24.00
Notes	All the above times are in UK Clock time		

Tariff name	Open LLFCs / DUoS Tariff IDs	PCs	Red/black unit charge p/kWh	Amber/yellow unit charge p/kWh	Green unit charge p/kWh	Fixed charge p/MPAN/day	Capacity charge p/kVA/day	Exceeded capacity charge p/kVA/day	Reactive power charge p/kVArh	Closed LLFCs / DUoS Tariff IDs
Domestic Aggregated or CT with Residual	181, 261-262, 361-362, 480-481, 516, GA2	0, 1, 2	20.135	3.064	0.169	9.95				
Domestic Aggregated (Related MPAN)		2	20.135	3.064	0.169					
Non-Domestic Aggregated or CT No Residual	GA0, G10, G15, G20, G35, G40, G45, G55, G65, G70, G75, G90, GA3	0, 3, 4, 5-8	18.542	2.821	0.155	8.70				

Tariff name	Open LLFCs / DUoS Tariff IDs	PCs	Red/black unit charge p/kWh	Amber/yellow unit charge p/kWh	Green unit charge p/kWh	Fixed charge p/MPAN/day	Capacity charge p/kVA/day	Exceeded capacity charge p/kVA/day	Reactive power charge p/kVArh	Closed LLFCs / DUoS Tariff IDs
Non-Domestic Aggregated or CT Band 1	GA1, G11, G16, G21, G36, G41, G46, G56, G66, G71, G76, G91, GA4	0, 3, 4, 5-8	18.542	2.821	0.155	10.84				
Non-Domestic Aggregated or CT Band 2	G02, G12, G17, G22, G37, G42, G47, G57, G67, G72, G77, G92, GA5	0, 3, 4, 5-8	18.542	2.821	0.155	11.92				
Non-Domestic Aggregated or CT Band 3	G03, G13, G18, G23, G38, G43, G48, G58, G68, G73, G78, G93, GA6	0, 3, 4, 5-8	18.542	2.821	0.155	15.28				
Non-Domestic Aggregated or CT Band 4	G04, G14, G19, G24, G39, G44, G49, G59, G69, G74, G79, G94, GA7	0, 3, 4, 5-8	18.542	2.821	0.155	26.13				
Non-Domestic Aggregated (related MPAN)		4	18.542	2.821	0.155					
LV Site Specific No Residual	G05, G30, G80	0	12.275	1.829	0.099	28.31	8.65	8.65	0.240	
LV Site Specific Band 1	G06, G31, G81	0	12.275	1.829	0.099	64.68	8.65	8.65	0.240	
LV Site Specific Band 2	G07, G32, G82	0	12.275	1.829	0.099	87.57	8.65	8.65	0.240	
LV Site Specific Band 3	G08, G33, G83	0	12.275	1.829	0.099	124.62	8.65	8.65	0.240	
LV Site Specific Band 4	G09, G34, G84	0	12.275	1.829	0.099	241.46	8.65	8.65	0.240	
LV Sub Site Specific No Residual	G60, G95	0	8.991	1.306	0.070	91.37	10.03	10.03	0.171	
LV Sub Site Specific Band 1	G61, G96	0	8.991	1.306	0.070	127.74	10.03	10.03	0.171	

Tariff name	Open LLFCs / DUoS Tariff IDs	PCs	Red/black unit charge p/kWh	Amber/yellow unit charge p/kWh	Green unit charge p/kWh	Fixed charge p/MPAN/day	Capacity charge p/kVA/day	Exceeded capacity charge p/kVA/day	Reactive power charge p/kVAh	Closed LLFCs / DUoS Tariff IDs
LV Sub Site Specific Band 2	G62, G97	0	8.991	1.306	0.070	150.62	10.03	10.03	0.171	
LV Sub Site Specific Band 3	G63, G98	0	8.991	1.306	0.070	187.68	10.03	10.03	0.171	
LV Sub Site Specific Band 4	G64, G99	0	8.991	1.306	0.070	304.52	10.03	10.03	0.171	
HV Site Specific No Residual	G25, G50, G85	0	5.988	0.836	0.043	200.91	9.96	9.96	0.103	
HV Site Specific Band 1	G26, G51, G86	0	5.988	0.836	0.043	420.04	9.96	9.96	0.103	
HV Site Specific Band 2	G27, G52, G87	0	5.988	0.836	0.043	751.07	9.96	9.96	0.103	
HV Site Specific Band 3	G28, G53, G88	0	5.988	0.836	0.043	1308.06	9.96	9.96	0.103	
HV Site Specific Band 4	G29, G54, G89	0	5.988	0.836	0.043	2882.16	9.96	9.96	0.103	
Unmetered Supplies	267-268, 487-490, 560-564	0, 1 or 8	56.945	5.996	3.800					
LV Generation Aggregated	977, G01	0 or 8	-12.646	-1.924	-0.106	0.00				
LV Sub Generation Aggregated		0	-9.794	-1.466	-0.080	0.00				
LV Generation Site Specific	45, 367, R82	0	-12.646	-1.924	-0.106	0.00			0.228	
LV Generation Site Specific no RP charge	49-50, R83	0	-12.646	-1.924	-0.106	0.00				
LV Sub Generation Site Specific	46-47	0	-9.794	-1.466	-0.080	0.00			0.198	
LV Sub Generation Site Specific no RP charge	248-249	0	-9.794	-1.466	-0.080	0.00				
HV Generation Site Specific	48, 368	0	-7.196	-1.046	-0.056	13.53			0.160	

Tariff name	Open LLFCs / DUoS Tariff IDs	PCs	Red/black unit charge p/kWh	Amber/yellow unit charge p/kWh	Green unit charge p/kWh	Fixed charge p/MPAN/day	Capacity charge p/kVA/day	Exceeded capacity charge p/kVA/day	Reactive power charge p/kVArh	Closed LLFCs / DUoS Tariff IDs
HV Generation Site Specific no RP charge	339, 406	0	-7.196	-1.046	-0.056	13.53				

## Annex 1 - Schedule of Charges for use of the Distribution System by LV and HV Properties in “South Eastern Power Networks Area (GSP Group \_J)”

### Southern Electric Power Distribution plc - Effective from 1st April 2027 - Final LV and HV charges in UKPN SPN Area (GSP Group \_J)

Time Bands for LV and HV Properties			
Time periods	Red Time Band	Amber Time Band	Green Time Band
Monday to Friday (Including Bank Holidays) All Year	16:00 - 19:00	07:00 - 16:00 19:00 - 23:00	00:00 - 07:00 23:00 - 24:00
Saturday and Sunday All Year			00:00 - 24:00
Notes	All times are in UK Clock time		

Time Bands for Unmetered Properties			
	Black Time Band	Yellow Time Band	Green Time Band
Monday to Friday (Including Bank Holidays) November to February Inclusive	16:00 - 19:00	07:00 - 16:00 19:00 - 23:00	00:00 - 07:00 23:00 - 24:00
Monday to Friday (Including Bank Holidays) March to October Inclusive		07:00 - 23:00	00:00 - 07:00 23:00 - 24:00
Saturday and Sunday All Year			00:00 - 24:00
Notes	All times are in UK Clock time		

Tariff name	Open LLFCs / DUoS Tariff IDs	PCs	Red/black unit charge p/kWh	Amber/yellow unit charge p/kWh	Green unit charge p/kWh	Fixed charge p/MPAN/day	Capacity charge p/kVA/day	Exceeded capacity charge p/kVA/day	Reactive power charge p/kVAh	Closed LLFCs / DUoS Tariff IDs
Domestic Aggregated or CT with Residual	183, 371-372, 471-472, JA0	0, 1, 2	21.462	0.980	0.336	13.94				
Domestic Aggregated (Related MPAN)		2	21.462	0.980	0.336					
Non-Domestic Aggregated or CT No Residual	J10, J15, J20, J30, J40, J45, J50, JA1	0, 3, 4, 5-8	17.108	0.781	0.268	9.69				
Non-Domestic Aggregated or CT Band 1	J11, J16, J21, J31, J41, J46, J51, JA2	0, 3, 4, 5-8	17.108	0.781	0.268	13.89				
Non-Domestic Aggregated or CT Band 2	J12, J17, J22, J32, J42, J47, J52, JA3	0, 3, 4, 5-8	17.108	0.781	0.268	21.84				

Tariff name	Open LLFCs / DUoS Tariff IDs	PCs	Red/black unit charge p/kWh	Amber/yellow unit charge p/kWh	Green unit charge p/kWh	Fixed charge p/MPAN/day	Capacity charge p/kVA/day	Exceeded capacity charge p/kVA/day	Reactive power charge p/kVAh	Closed LLFCs / DUoS Tariff IDs
Non-Domestic Aggregated or CT Band 3	J13, J18, J23, J33, J43, J48, J53, JA4	0, 3, 4, 5-8	17.108	0.781	0.268	34.21				
Non-Domestic Aggregated or CT Band 4	J14, J19, J24, J34, J44, J49, J54, JA5	0, 3, 4, 5-8	17.108	0.781	0.268	77.36				
Non-Domestic Aggregated (related MPAN)		4	17.108	0.781	0.268					
LV Site Specific No Residual	J05	0	12.691	0.542	0.189	22.54	9.33	9.33	0.424	
LV Site Specific Band 1	J06	0	12.691	0.542	0.189	186.50	9.33	9.33	0.424	
LV Site Specific Band 2	J07	0	12.691	0.542	0.189	308.19	9.33	9.33	0.424	
LV Site Specific Band 3	J08	0	12.691	0.542	0.189	443.84	9.33	9.33	0.424	
LV Site Specific Band 4	J09	0	12.691	0.542	0.189	983.43	9.33	9.33	0.424	
LV Sub Site Specific No Residual	J35	0	8.117	0.305	0.110	18.97	7.72	7.72	0.259	
LV Sub Site Specific Band 1	J36	0	8.117	0.305	0.110	182.93	7.72	7.72	0.259	
LV Sub Site Specific Band 2	J37	0	8.117	0.305	0.110	304.62	7.72	7.72	0.259	
LV Sub Site Specific Band 3	J38	0	8.117	0.305	0.110	440.27	7.72	7.72	0.259	
LV Sub Site Specific Band 4	J39	0	8.117	0.305	0.110	979.86	7.72	7.72	0.259	
HV Site Specific No Residual	J25	0	6.640	0.229	0.085	201.09	6.96	6.96	0.213	
HV Site Specific Band 1	J26	0	6.640	0.229	0.085	1435.10	6.96	6.96	0.213	
HV Site Specific Band 2	J27	0	6.640	0.229	0.085	3333.99	6.96	6.96	0.213	

Tariff name	Open LLFCs / DUoS Tariff IDs	PCs	Red/black unit charge p/kWh	Amber/yellow unit charge p/kWh	Green unit charge p/kWh	Fixed charge p/MPAN/day	Capacity charge p/kVA/day	Exceeded capacity charge p/kVA/day	Reactive power charge p/kVAh	Closed LLFCs / DUoS Tariff IDs
HV Site Specific Band 3	J28	0	6.640	0.229	0.085	4268.57	6.96	6.96	0.213	
HV Site Specific Band 4	J29	0	6.640	0.229	0.085	12178.60	6.96	6.96	0.213	
Unmetered Supplies	565-569, J00	0, 1 or 8	59.984	3.384	2.745					
LV Generation Aggregated	979, J01	0 or 8	-13.185	-0.602	-0.206	0.00				
LV Sub Generation Aggregated		0	-10.608	-0.463	-0.161	0.00				
LV Generation Site Specific	51, 377, J02	0	-13.185	-0.602	-0.206	0.00			0.464	
LV Generation Site Specific no RP charge	55-56, J03	0	-13.185	-0.602	-0.206	0.00				
LV Sub Generation Site Specific	52-53	0	-10.608	-0.463	-0.161	0.00			0.348	
LV Sub Generation Site Specific no RP charge	408, 413	0	-10.608	-0.463	-0.161	0.00				
HV Generation Site Specific	54, 378	0	-7.474	-0.280	-0.101	14.11			0.302	
HV Generation Site Specific no RP charge	510-511	0	-7.474	-0.280	-0.101	14.11				

## Annex 1 - Schedule of Charges for use of the Distribution System by LV and HV Properties in “NGED South Wales Area (GSP Group \_K)”

### Southern Electric Power Distribution plc - Effective from 1st April 2027 - Final LV and HV charges in NGED South Wales Area (GSP Group \_K)

Time Bands for LV and HV Properties			
Time periods	Red Time Band	Amber Time Band	Green Time Band
Monday to Friday (Including Bank Holidays) All Year	17:00 to 19:30	07:30 to 17:00 19:30 to 22:00	00:00 to 07:30 22:00 to 24:00
Saturday and Sunday All Year		12:00 to 13:00 16:00 to 21:00	00:00 to 12:00 13:00 to 16:00 21:00 to 24:00
Notes	All the above times are in UK Clock time		

Time Bands for Unmetered Properties			
	Black Time Band	Yellow Time Band	Green Time Band
Monday to Friday (Including Bank Holidays) Nov to Feb Inclusive (excluding 22nd Dec to 4th Jan inclusive)	17:00 to 19:30	07:30 to 17:00 19:30 to 22:00	00:00 to 07:30 22:00 to 24:00
Monday to Friday (Including Bank Holidays) Mar to Oct Inclusive (plus 22nd Dec to 4th Jan inclusive)		07:30 to 22:00	00:00 to 07:30 22:00 to 24:00
Saturday and Sunday All Year		12:00 to 13:00 16:00 to 21:00	00:00 to 12:00 13:00 to 16:00 21:00 to 24:00
Notes	All the above times are in UK Clock time		

Tariff name	Open LLFCs / DUoS Tariff IDs	PCs	Red/black unit charge p/kWh	Amber/yellow unit charge p/kWh	Green unit charge p/kWh	Fixed charge p/MPAN/day	Capacity charge p/kVA/day	Exceeded capacity charge p/kVA/day	Reactive power charge p/kVAh	Closed LLFCs / DUoS Tariff IDs
Domestic Aggregated or CT with Residual	81-82, 91-92, 98-99, 185, 291-292, 518, K04, KA0	0, 1, 2	19.172	1.769	0.344	16.23				
Domestic Aggregated (Related MPAN)		2	19.172	1.769	0.344					
Non-Domestic Aggregated or CT No Residual	K10, K30, K35, K40, K50, K60, K65, K70, K80, K90, K95, R45, R50, KA1	0, 3, 4, 5-8	19.843	1.831	0.356	16.35				

Tariff name	Open LLFCs / DUoS Tariff IDs	PCs	Red/black unit charge p/kWh	Amber/yellow unit charge p/kWh	Green unit charge p/kWh	Fixed charge p/MPAN/day	Capacity charge p/kVA/day	Exceeded capacity charge p/kVA/day	Reactive power charge p/kVArh	Closed LLFCs / DUoS Tariff IDs
Non-Domestic Aggregated or CT Band 1	K11, K31, K36, K41, K51, K61, K66, K71, K81, K91, K96, R46, R51, KA2	0, 3, 4, 5-8	19.843	1.831	0.356	22.49				
Non-Domestic Aggregated or CT Band 2	K12, K32, K37, K42, K52, K62, K67, K72, K82, K92, K97, R47, R52, KA3	0, 3, 4, 5-8	19.843	1.831	0.356	33.37				
Non-Domestic Aggregated or CT Band 3	K13, K33, K38, K43, K53, K63, K68, K73, K83, K93, K98, R48, R53, KA4	0, 3, 4, 5-8	19.843	1.831	0.356	52.17				
Non-Domestic Aggregated or CT Band 4	K14, K34, K39, K44, K54, K64, K69, K74, K84, K94, K99, R49, R54, KA5	0, 3, 4, 5-8	19.843	1.831	0.356	108.73				
Non-Domestic Aggregated (related MPAN)		4	19.843	1.831	0.356					
LV Site Specific No Residual	K15, K25, K55	0	12.754	1.111	0.232	18.62	11.06	11.06	0.309	
LV Site Specific Band 1	K16, K26, K56	0	12.754	1.111	0.232	178.79	11.06	11.06	0.309	
LV Site Specific Band 2	K17, K27, K57	0	12.754	1.111	0.232	326.94	11.06	11.06	0.309	
LV Site Specific Band 3	K18, K28, K58	0	12.754	1.111	0.232	539.01	11.06	11.06	0.309	
LV Site Specific Band 4	K19, K29, K59	0	12.754	1.111	0.232	1243.10	11.06	11.06	0.309	
LV Sub Site Specific No Residual	K85	0	8.276	0.607	0.157	14.54	10.38	10.38	0.188	
LV Sub Site Specific Band 1	K86	0	8.276	0.607	0.157	174.70	10.38	10.38	0.188	
LV Sub Site Specific Band 2	K87	0	8.276	0.607	0.157	322.85	10.38	10.38	0.188	
LV Sub Site Specific Band 3	K88	0	8.276	0.607	0.157	534.92	10.38	10.38	0.188	

Tariff name	Open LLFCs / DUoS Tariff IDs	PCs	Red/black unit charge p/kWh	Amber/yellow unit charge p/kWh	Green unit charge p/kWh	Fixed charge p/MPAN/day	Capacity charge p/kVA/day	Exceeded capacity charge p/kVA/day	Reactive power charge p/kVAh	Closed LLFCs / DUoS Tariff IDs
LV Sub Site Specific Band 4	K89	0	8.276	0.607	0.157	1239.01	10.38	10.38	0.188	
HV Site Specific No Residual	K20, K45, K75	0	5.501	0.368	0.104	134.20	10.74	10.74	0.119	
HV Site Specific Band 1	K21, K46, K76	0	5.501	0.368	0.104	1270.02	10.74	10.74	0.119	
HV Site Specific Band 2	K22, K47, K77	0	5.501	0.368	0.104	3093.63	10.74	10.74	0.119	
HV Site Specific Band 3	K23, K48, K78	0	5.501	0.368	0.104	5669.10	10.74	10.74	0.119	
HV Site Specific Band 4	K24, K49, K79	0	5.501	0.368	0.104	13094.04	10.74	10.74	0.119	
Unmetered Supplies	88, 97, 197-199, 570-574, K06	0, 1 or 8	62.704	3.825	2.348					
LV Generation Aggregated	982, K07	0 or 8	-12.614	-1.164	-0.226	0.00				
LV Sub Generation Aggregated		0	-10.955	-0.978	-0.198	0.00				
LV Generation Site Specific	57, 297, K08	0	-12.614	-1.164	-0.226	0.00			0.376	
LV Generation Site Specific no RP charge	61-62, K09	0	-12.614	-1.164	-0.226	0.00				
LV Sub Generation Site Specific	58-59	0	-10.955	-0.978	-0.198	0.00			0.281	
LV Sub Generation Site Specific no RP charge	K00-K01	0	-10.955	-0.978	-0.198	0.00				
HV Generation Site Specific	60, 298	0	-6.536	-0.479	-0.124	83.99			0.239	
HV Generation Site Specific no RP charge	K02-K03	0	-6.536	-0.479	-0.124	83.99				

## Annex 1 - Schedule of Charges for use of the Distribution System by LV and HV Properties in “NGED South West Area (GSP Group \_L)”

### Southern Electric Power Distribution plc - Effective from 1st April 2027 - Final LV and HV charges in NGED South West Area (GSP Group \_L)

Time Bands for LV and HV Properties			
Time periods	Red Time Band	Amber Time Band	Green Time Band
Monday to Friday (Including Bank Holidays) All Year	17.00 - 19.00	07:30 to 17:00 19:00 to 21:30	00:00 to 07:30 21:30 to 24:00
Saturday and Sunday All year		16:30 to 19:30	00:00 to 16:30 19:30 to 24:00
Notes	All the above times are in UK Clock time		

Time Bands for Unmetered Properties			
	Black Time Band	Yellow Time Band	Green Time Band
Monday to Friday (Including Bank Holidays) Nov to Feb Inclusive (excluding 22nd Dec to 4th Jan inclusive)	17:00 to 19:00	07:30 to 17:00 19:00 to 21:30	00:00 to 07:30 21:30 to 24:00
Monday to Friday (Including Bank Holidays) Mar to Oct Inclusive (plus 22nd Dec to 4th Jan inclusive)		07:30 to 21:30	00:00 to 07:30 21:30 to 24:00
Saturday and Sunday All year		16:30 to 19:30	00:00 to 16:30 19:30 to 24:00
Notes	All the above times are in UK Clock time		

Tariff name	Open LLFCs / DUoS Tariff IDs	PCs	Red/black unit charge p/kWh	Amber/yellow unit charge p/kWh	Green unit charge p/kWh	Fixed charge p/MPAN/day	Capacity charge p/kVA/day	Exceeded capacity charge p/kVA/day	Reactive power charge p/kVAh	Closed LLFCs / DUoS Tariff IDs
Domestic Aggregated or CT with Residual	187, 381-382, L08, LA0	0, 1, 2	25.395	2.026	0.200	17.83				
Domestic Aggregated (Related MPAN)		2	25.395	2.026	0.200					
Non-Domestic Aggregated or CT No Residual	L10, L15, L20, L30, L45, L50, L55, R55, LA1	0, 3, 4, 5-8	24.844	1.982	0.196	19.25				
Non-Domestic Aggregated or CT Band 1	L11, L16, L21, L31, L46, L51, L56, R56, LA2	0, 3, 4, 5-8	24.844	1.982	0.196	22.53				

Tariff name	Open LLFCs / DUoS Tariff IDs	PCs	Red/black unit charge p/kWh	Amber/yellow unit charge p/kWh	Green unit charge p/kWh	Fixed charge p/MPAN/day	Capacity charge p/kVA/day	Exceeded capacity charge p/kVA/day	Reactive power charge p/kVAh	Closed LLFCs / DUoS Tariff IDs
Non-Domestic Aggregated or CT Band 2	L12, L17, L22, L32, L47, L52, L57, R57, LA3	0, 3, 4, 5-8	24.844	1.982	0.196	32.59				
Non-Domestic Aggregated or CT Band 3	L13, L18, L23, L33, L48, L53, L58, R58, LA4	0, 3, 4, 5-8	24.844	1.982	0.196	46.07				
Non-Domestic Aggregated or CT Band 4	L14, L19, L24, L34, L49, L54, L59, R59, LA5	0, 3, 4, 5-8	24.844	1.982	0.196	84.44				
Non-Domestic Aggregated (related MPAN)		4	24.844	1.982	0.196					
LV Site Specific No Residual	L60, R60	0	15.429	1.097	0.111	19.09	12.91	12.91	0.253	
LV Site Specific Band 1	L61, R61	0	15.429	1.097	0.111	142.31	12.91	12.91	0.253	
LV Site Specific Band 2	L62, R62	0	15.429	1.097	0.111	240.23	12.91	12.91	0.253	
LV Site Specific Band 3	L63, R63	0	15.429	1.097	0.111	370.59	12.91	12.91	0.253	
LV Site Specific Band 4	L64, R64	0	15.429	1.097	0.111	797.99	12.91	12.91	0.253	
LV Sub Site Specific No Residual	L35	0	9.821	0.496	0.054	14.90	11.05	11.05	0.139	
LV Sub Site Specific Band 1	L36	0	9.821	0.496	0.054	138.12	11.05	11.05	0.139	
LV Sub Site Specific Band 2	L37	0	9.821	0.496	0.054	236.04	11.05	11.05	0.139	
LV Sub Site Specific Band 3	L38	0	9.821	0.496	0.054	366.41	11.05	11.05	0.139	
LV Sub Site Specific Band 4	L39	0	9.821	0.496	0.054	793.80	11.05	11.05	0.139	
HV Site Specific No Residual	L25, L40	0	7.500	0.288	0.033	137.54	10.62	10.62	0.097	

Tariff name	Open LLFCs / DUoS Tariff IDs	PCs	Red/black unit charge p/kWh	Amber/yellow unit charge p/kWh	Green unit charge p/kWh	Fixed charge p/MPAN/day	Capacity charge p/kVA/day	Exceeded capacity charge p/kVA/day	Reactive power charge p/kVArh	Closed LLFCs / DUoS Tariff IDs
HV Site Specific Band 1	L26, L41	0	7.500	0.288	0.033	1035.09	10.62	10.62	0.097	
HV Site Specific Band 2	L27, L42	0	7.500	0.288	0.033	2208.42	10.62	10.62	0.097	
HV Site Specific Band 3	L28, L43	0	7.500	0.288	0.033	4821.80	10.62	10.62	0.097	
HV Site Specific Band 4	L29, L44	0	7.500	0.288	0.033	9159.74	10.62	10.62	0.097	
Unmetered Supplies	575-579, L04	0, 1 or 8	75.808	4.150	2.062					
LV Generation Aggregated	985, L05	0 or 8	-15.280	-1.219	-0.121	0.00				
LV Sub Generation Aggregated		0	-13.109	-0.975	-0.097	0.00				
LV Generation Site Specific	63, 387, L06	0	-15.280	-1.219	-0.121	0.00			0.312	
LV Generation Site Specific no RP charge	67-68, L07	0	-15.280	-1.219	-0.121	0.00				
LV Sub Generation Site Specific	64-65	0	-13.109	-0.975	-0.097	0.00			0.224	
LV Sub Generation Site Specific no RP charge	L00-L01	0	-13.109	-0.975	-0.097	0.00				
HV Generation Site Specific	66, 388	0	-8.196	-0.414	-0.045	86.08			0.187	
HV Generation Site Specific no RP charge	L02-L03	0	-8.196	-0.414	-0.045	86.08				

## Annex 1 - Schedule of Charges for use of the Distribution System by LV and HV Properties in “Northern Powergrid (Yorkshire) Area (GSP Group \_M)”

### Southern Electric Power Distribution plc - Effective from 1st April 2027 - Final LV and HV charges in NPG Yorkshire Area (GSP Group \_M)

Time Bands for LV and HV Properties			
Time periods	Red Time Band	Amber Time Band	Green Time Band
Monday to Friday (Including Bank Holidays) All Year	16:00 to 19:30	08:00 to 16:00 19:30 to 22:00	00:00 to 08:00 22:00 to 24:00
Saturday and Sunday All Year			00:00 to 24:00
Notes	All the above times are in UK Clock time		

Time Bands for Unmetered Properties			
	Black Time Band	Yellow Time Band	Green Time Band
Monday to Friday (Including Bank Holidays) November to February Inclusive	16:00 to 19:30	08:00 to 16:00 19:30 to 22:00	00:00 to 08:00 22:00 to 24:00
Monday to Friday (Including Bank Holidays) April to October Inclusive and March		08:00 to 22:00	00:00 to 08:00 22:00 to 24:00
Saturday and Sunday All Year			00:00 to 24:00
Notes	All the above times are in UK Clock time		

Tariff name	Open LLFCs / DUoS Tariff IDs	PCs	Red/black unit charge p/kWh	Amber/yellow unit charge p/kWh	Green unit charge p/kWh	Fixed charge p/MPAN/day	Capacity charge p/kVA/day	Exceeded capacity charge p/kVA/day	Reactive power charge p/kVArh	Closed LLFCs / DUoS Tariff IDs
Domestic Aggregated or CT with Residual	189, 391-392, 491-492, 522, MA0	0, 1, 2	7.705	1.886	0.249	19.54				
Domestic Aggregated (Related MPAN)	389	2	7.705	1.886	0.249					
Non-Domestic Aggregated or CT No Residual	M10, M15, M20, M30, M35, M45, M50, M55, R70, MA1	0, 3, 4, 5- 8	8.754	2.143	0.283	11.84				
Non-Domestic Aggregated or CT Band 1	M11, M16, M21, M31, M36, M46, M51, M56, R71, MA2	0, 3, 4, 5- 8	8.754	2.143	0.283	20.26				

Tariff name	Open LLFCs / DUoS Tariff IDs	PCs	Red/black unit charge p/kWh	Amber/yellow unit charge p/kWh	Green unit charge p/kWh	Fixed charge p/MPAN/day	Capacity charge p/kVA/day	Exceeded capacity charge p/kVA/day	Reactive power charge p/kVArh	Closed LLFCs / DUoS Tariff IDs
Non-Domestic Aggregated or CT Band 2	M12, M17, M22, M32, M37, M47, M52, M57, R72, MA3	0, 3, 4, 5-8	8.754	2.143	0.283	31.15				
Non-Domestic Aggregated or CT Band 3	M13, M18, M23, M33, M38, M48, M53, M58, R73, MA4	0, 3, 4, 5-8	8.754	2.143	0.283	51.92				
Non-Domestic Aggregated or CT Band 4	M14, M19, M24, M34, M39, M49, M54, M59, R74, MA5	0, 3, 4, 5-8	8.754	2.143	0.283	122.30				
Non-Domestic Aggregated (related MPAN)		4	8.754	2.143	0.283					
LV Site Specific No Residual	M60, R65	0	6.297	1.515	0.194	15.22	4.01	4.01	0.097	
LV Site Specific Band 1	M61, R66	0	6.297	1.515	0.194	205.28	4.01	4.01	0.097	
LV Site Specific Band 2	M62, R67	0	6.297	1.515	0.194	390.64	4.01	4.01	0.097	
LV Site Specific Band 3	M63, R68	0	6.297	1.515	0.194	589.97	4.01	4.01	0.097	
LV Site Specific Band 4	M64, R69	0	6.297	1.515	0.194	1285.24	4.01	4.01	0.097	
LV Sub Site Specific No Residual	M40	0	3.966	0.915	0.109	15.22	3.14	3.14	0.055	
LV Sub Site Specific Band 1	M41	0	3.966	0.915	0.109	205.28	3.14	3.14	0.055	
LV Sub Site Specific Band 2	M42	0	3.966	0.915	0.109	390.64	3.14	3.14	0.055	
LV Sub Site Specific Band 3	M43	0	3.966	0.915	0.109	589.97	3.14	3.14	0.055	

Tariff name	Open LLFCs / DUoS Tariff IDs	PCs	Red/black unit charge p/kWh	Amber/yellow unit charge p/kWh	Green unit charge p/kWh	Fixed charge p/MPAN/day	Capacity charge p/kVA/day	Exceeded capacity charge p/kVA/day	Reactive power charge p/kVArh	Closed LLFCs / DUoS Tariff IDs
LV Sub Site Specific Band 4	M44	0	3.966	0.915	0.109	1285.24	3.14	3.14	0.055	
HV Site Specific No Residual	M25	0	2.677	0.588	0.063	398.64	4.04	4.04	0.034	
HV Site Specific Band 1	M26	0	2.677	0.588	0.063	1677.29	4.04	4.04	0.034	
HV Site Specific Band 2	M27	0	2.677	0.588	0.063	4158.08	4.04	4.04	0.034	
HV Site Specific Band 3	M28	0	2.677	0.588	0.063	7773.31	4.04	4.04	0.034	
HV Site Specific Band 4	M29	0	2.677	0.588	0.063	19200.42	4.04	4.04	0.034	
Unmetered Supplies	580-584, M05	0, 1 or 8	22.229	2.499	1.093					
LV Generation Aggregated	987, M06	0 or 8	-5.382	-1.317	-0.174					
LV Sub Generation Aggregated		0	-4.387	-1.063	-0.138					
LV Generation Site Specific	69, 397, M07	0	-5.382	-1.317	-0.174				0.076	
LV Generation Site Specific no RP charge	73-74, M08	0	-5.382	-1.317	-0.174					
LV Sub Generation Site Specific	70-71	0	-4.387	-1.063	-0.138				0.068	
LV Sub Generation Site Specific no RP charge	M00-M01	0	-4.387	-1.063	-0.138					
HV Generation Site Specific	72, 398	0	-3.097	-0.715	-0.085	88.59			0.060	
HV Generation Site Specific no RP charge	M02-M03	0	-3.097	-0.715	-0.085	88.59				

## Annex 2 - Schedule of Charges for use of the Distribution System by EHV Properties (including LDNOs with EHV Properties/end-users) in “Eastern Power Networks Area (GSP Group \_A)”

Note: The list of MPANs / MSIDs provided may be incomplete; the DNO reserves the right to apply the listed charges to any other MPANs / MSIDs associated with the site.

### Southern Electric Power Distribution plc - Effective from 1 April 2027 - Final Schedule of Charges for use of the Distribution System by EHV Properties (including LDNOs with EHV Properties/end-users) in UKPN EPN Area (GSP Group \_A)

Time Periods for EHV Properties	
Time periods	Super Red Time Band
Monday to Friday (Including Bank Holidays) November to February Inclusive	16:00 - 19:00
Notes	All times are in UK Clock time

Import LLFC / DUoS Tariff ID	Import MPANs/MSIDs	Export LLFC / DUoS Tariff ID	Export MPANs/MSIDs	Tariff	Residual Charging Band	Import Super Red unit charge (p/kWh)	Import fixed charge (p/day)	Import capacity charge (p/kVA/day)	Import exceeded capacity charge (p/kVA/day)	Export Super Red unit charge (p/kWh)	Export fixed charge (p/day)	Export capacity charge (p/kVA/day)	Export exceeded capacity charge (p/kVA/day)
590	2000055139358				1	2.651	5,664.10	1.14	1.14				
590	2000055139428				1	2.651	5,664.10	1.14	1.14				
590	2000055139385				2	2.651	25,488.47	1.14	1.14				
590	2000055139455				2	2.651	25,488.47	1.14	1.14				
590	2000055139394				2	2.651	25,488.47	1.14	1.14				
590	2000055139464				2	2.651	25,488.47	1.14	1.14				
591	2000054395187, 2000054395178, 2000054395201, 2000054395196				3	0.111	105,101.01	2.28	2.28				
593	2000055139367, 2000055139437				1	2.651	8,496.16	1.14	1.14				
594	2000055139376, 2000055139446				2	2.651	48,144.89	1.14	1.14				

Note: as Site Specific Tariffs under LLFCs 590, 593 and 594 of \_A area share the same LDSO boundary, the Host DNO's residual band 4 charges were apportioned between these sites rather than applied individually to each End User. The residual charging band descriptions shown above reflect the maximum import capacity of each End User.

## Annex 2 - Schedule of Charges for use of the Distribution System by EHV Properties (including LDNOs with EHV Properties/end-users) in “NGED East Midlands Area (GSP Group \_B)”

Note: The list of MPANs / MSIDs provided may be incomplete; the DNO reserves the right to apply the listed charges to any other MPANs / MSIDs associated with the site.

### Southern Electric Power Distribution plc - Effective from 1 April 2027 - Final Schedule of Charges for use of the Distribution System by EHV Properties (including LDNOs with EHV Properties/end-users) in NGED EM Area (GSP Group \_B)

Time Periods for EHV Properties	
Time periods	Super Red Time Band
Monday to Friday (Including Bank Holidays) November to February Inclusive	16:00 to 19:00
Notes	All the above times are in UK Clock time

Import LLFC / DUoS Tariff ID	Import MPANs/MSIDs	Export LLFC / DUoS Tariff ID	Export MPANs/MSIDs	Tariff	Residual Charging Band	Import Super Red unit charge (p/kWh)	Import fixed charge (p/day)	Import capacity charge (p/kVA/day)	Import exceeded capacity charge (p/kVA/day)	Export Super Red unit charge (p/kWh)	Export fixed charge (p/day)	Export capacity charge (p/kVA/day)	Export exceeded capacity charge (p/kVA/day)

**Annex 2 - Schedule of Charges for use of the Distribution System by EHV Properties (including LDNOs with EHV Properties/end-users) in “London Power Networks Area (GSP Group \_C)”**

Note: The list of MPANs / MSIDs provided may be incomplete; the DNO reserves the right to apply the listed charges to any other MPANs / MSIDs associated with the site.

**Southern Electric Power Distribution plc - Effective from 1 April 2027 - Final Schedule of Charges for use of the Distribution System by EHV Properties (including LDNOs with EHV Properties/end-users) in UKPN LPN Area (GSP Group \_C)**

Time Periods for EHV Properties	
Time periods	Super Red Time Band
Monday to Friday (Including Bank Holidays) June to August Inclusive	11:00 - 14:00
Monday to Friday (Including Bank Holidays) November to February Inclusive	16:00 - 19:00
Notes	All times are in UK Clock time

Import LLFC / DUoS Tariff ID	Import MPANs/MSIDs	Export LLFC / DUoS Tariff ID	Export MPANs/MSIDs	Tariff	Residual Charging Band	Import Super Red unit charge (p/kWh)	Import fixed charge (p/day)	Import capacity charge (p/kVA/day)	Import exceeded capacity charge (p/kVA/day)	Export Super Red unit charge (p/kWh)	Export fixed charge (p/day)	Export capacity charge (p/kVA/day)	Export exceeded capacity charge (p/kVA/day)

## Annex 2 - Schedule of Charges for use of the Distribution System by EHV Properties (including LDNOs with EHV Properties/end-users) in “SP Manweb Area (GSP Group \_D)”

Note: The list of MPANs / MSIDs provided may be incomplete; the DNO reserves the right to apply the listed charges to any other MPANs / MSIDs associated with the site.

### Southern Electric Power Distribution plc - Effective from 1 April 2027 - Final Schedule of Charges for use of the Distribution System by EHV Properties (including LDNOs with EHV Properties/end-users) in SP Manweb Area (GSP Group \_D)

Time Periods for EHV Properties	
Time periods	Super Red Time Band
Monday to Friday (Including Bank Holidays) June to August Inclusive	
Monday to Friday (Including Bank Holidays) November to February Inclusive	16:30 - 19:30
Notes	All the above times are in UK Clock time

Import LLFC / DUoS Tariff ID	Import MPANs/MSIDs	Export LLFC / DUoS Tariff ID	Export MPANs/MSIDs	Tariff	Residual Charging Band	Import Super Red unit charge (p/kWh)	Import fixed charge (p/day)	Import capacity charge (p/kVA/day)	Import exceeded capacity charge (p/kVA/day)	Export Super Red unit charge (p/kWh)	Export fixed charge (p/day)	Export capacity charge (p/kVA/day)	Export exceeded capacity charge (p/kVA/day)

**Annex 2 - Schedule of Charges for use of the Distribution System by EHV Properties (including LDNOs with EHV Properties/end-users in “NGED West Midlands Area (GSP Group \_E)”**

Note: The list of MPANs / MSIDs provided may be incomplete; the DNO reserves the right to apply the listed charges to any other MPANs / MSIDs associated with the site.

**Southern Electric Power Distribution plc - Effective from 1 April 2027 - Final Schedule of Charges for use of the Distribution System by EHV Properties (including LDNOs with EHV Properties/end-users) in NGED West Midlands Area (GSP Group \_E)**

Time Periods for EHV Properties	
Time periods	Super Red Time Band
Monday to Friday (Including Bank Holidays) November to February Inclusive	16:00 to 19:00
Notes	All the above times are in UK Clock time

Import LLFC / DUoS Tariff ID	Import MPANs/MSIDs	Export LLFC / DUoS Tariff ID	Export MPANs/MSIDs	Tariff	Residual Charging Band	Import Super Red unit charge (p/kWh)	Import fixed charge (p/day)	Import capacity charge (p/kVA/day)	Import exceeded capacity charge (p/kVA/day)	Export Super Red unit charge (p/kWh)	Export fixed charge (p/day)	Export capacity charge (p/kVA/day)	Export exceeded capacity charge (p/kVA/day)

**Annex 2 - Schedule of Charges for use of the Distribution System by EHV Properties (including LDNOs with EHV Properties/end-users) in “Northern Powergrid (Northeast) Area (GSP Group \_F)”**

Note: The list of MPANs / MSIDs provided may be incomplete; the DNO reserves the right to apply the listed charges to any other MPANs / MSIDs associated with the site.

**Southern Electric Power Distribution plc - Effective from 1 April 2027 - Final Schedule of Charges for use of the Distribution System by EHV Properties (including LDNOs with EHV Properties/end-users) in NPG Northeast Area (GSP Group \_F)**

Time Periods for EHV Properties	
Time periods	Super Red Time Band
Monday to Friday (Including Bank Holidays) November to February Inclusive	1600 - 1930
Notes	All the above times are in UK Clock time

Import LLFC / DUoS Tariff ID	Import MPANs/MSIDs	Export LLFC / DUoS Tariff ID	Export MPANs/MSIDs	Tariff	Residual Charging Band	Import Super Red unit charge (p/kWh)	Import fixed charge (p/day)	Import capacity charge (p/kVA/day)	Import exceeded capacity charge (p/kVA/day)	Export Super Red unit charge (p/kWh)	Export fixed charge (p/day)	Export capacity charge (p/kVA/day)	Export exceeded capacity charge (p/kVA/day)
592	2000055132478, 2000055132487				3	0.000	95,940.29	0.97	0.97				

**Annex 2 - Schedule of Charges for use of the Distribution System by EHV Properties (including LDNOs with EHV Properties/end-users) in “SP Electricity North West Area (GSP Group \_G)”**

Note: The list of MPANs / MSIDs provided may be incomplete; the DNO reserves the right to apply the listed charges to any other MPANs / MSIDs associated with the site.

**Southern Electric Power Distribution plc - Effective from 1 April 2027 - Final Schedule of Charges for use of the Distribution System by EHV Properties (including LDNOs with EHV Properties/end-users) in SP Electricity North West Area (GSP Group \_G)**

Time Periods for EHV Properties	
Time periods	Super Red Time Band
Monday to Friday (Including Bank Holidays) November to February Inclusive	16:00 - 19:00
Notes	All the above times are in UK Clock time

Import LLFC / DUoS Tariff ID	Import MPANs/MSIDs	Export LLFC / DUoS Tariff ID	Export MPANs/MSIDs	Tariff	Residual Charging Band	Import Super Red unit charge (p/kWh)	Import fixed charge (p/day)	Import capacity charge (p/kVA/day)	Import exceeded capacity charge (p/kVA/day)	Export Super Red unit charge (p/kWh)	Export fixed charge (p/day)	Export capacity charge (p/kVA/day)	Export exceeded capacity charge (p/kVA/day)

**Annex 2 - Schedule of Charges for use of the Distribution System by EHV Properties (including LDNOs with EHV Properties/end-users)  
 “South Eastern Power Networks Area (GSP Group \_J)”**

Note: The list of MPANs / MSIDs provided may be incomplete; the DNO reserves the right to apply the listed charges to any other MPANs / MSIDs associated with the site.

**Southern Electric Power Distribution plc - Effective from 1 April 2027 - Final Schedule of Charges for use of the Distribution System by EHV Properties (including LDNOs with EHV Properties/end-users) in UKPN SPN Area (GSP Group \_J)**

Time Periods for EHV Properties	
Time periods	Super Red Time Band
Monday to Friday (Including Bank Holidays) November to February Inclusive	16:00 - 19:00
Notes	All times are in UK Clock time

Import LLFC / DUoS Tariff ID	Import MPANs/MSIDs	Export LLFC / DUoS Tariff ID	Export MPANs/MSIDs	Tariff	Residual Charging Band	Import Super Red unit charge (p/kWh)	Import fixed charge (p/day)	Import capacity charge (p/kVA/day)	Import exceeded capacity charge (p/kVA/day)	Export Super Red unit charge (p/kWh)	Export fixed charge (p/day)	Export capacity charge (p/kVA/day)	Export exceeded capacity charge (p/kVA/day)
773	2000055540650, 2000055540660				3	0.006	133,146.37	0.90	0.90				

**Annex 2 - Schedule of Charges for use of the Distribution System by EHV Properties (including LDNOs with EHV Properties/end-users) in “NGED South Wales Area (GSP Group \_K)”**

Note: The list of MPANs / MSIDs provided may be incomplete; the DNO reserves the right to apply the listed charges to any other MPANs / MSIDs associated with the site.

**Southern Electric Power Distribution plc - Effective from 1 April 2027 - Final Schedule of Charges for use of the Distribution System by EHV Properties (including LDNOs with EHV Properties/end-users) in NGED South Wales Area (GSP Group \_K)**

Time Periods for EHV Properties	
Time periods	Super Red Time Band
Monday to Friday (Including Bank Holidays) November to February Inclusive (excluding 22nd Dec to 4th Jan inclusive)	17:00 - 19:30
Notes	All the above times are in UK Clock time

Import LLFC / DUoS Tariff ID	Import MPANs/MSIDs	Export LLFC / DUoS Tariff ID	Export MPANs/MSIDs	Tariff	Residual Charging Band	Import Super Red unit charge (p/kWh)	Import fixed charge (p/day)	Import capacity charge (p/kVA/day)	Import exceeded capacity charge (p/kVA/day)	Export Super Red unit charge (p/kWh)	Export fixed charge (p/day)	Export capacity charge (p/kVA/day)	Export exceeded capacity charge (p/kVA/day)

**Annex 2 - Schedule of Charges for use of the Distribution System by EHV Properties (including LDNOs with EHV Properties/end-users) in “NGED South West Area (GSP Group \_L)”**

Note: The list of MPANs / MSIDs provided may be incomplete; the DNO reserves the right to apply the listed charges to any other MPANs / MSIDs associated with the site.

**Southern Electric Power Distribution plc - Effective from 1 April 2027 - Final Schedule of Charges for use of the Distribution System by EHV Properties (including LDNOs with EHV Properties/end-users) in NGED South West Area (GSP Group \_L)**

Time Periods for EHV Properties	
Time periods	Super Red Time Band
Monday to Friday (Including Bank Holidays) November to February Inclusive (excluding 22nd Dec to 4th Jan inclusive)	17:00 - 19:00
Notes	All the above times are in UK Clock time

Import LLFC / DUoS Tariff ID	Import MPANs/MSIDs	Export LLFC / DUoS Tariff ID	Export MPANs/MSIDs	Tariff	Residual Charging Band	Import Super Red unit charge (p/kWh)	Import fixed charge (p/day)	Import capacity charge (p/kVA/day)	Import exceeded capacity charge (p/kVA/day)	Export Super Red unit charge (p/kWh)	Export fixed charge (p/day)	Export capacity charge (p/kVA/day)	Export exceeded capacity charge (p/kVA/day)

## Annex 2 - Schedule of Charges for use of the Distribution System by EHV Properties (including LDNOs with EHV Properties/end-users) in “Northern Powergrid (Yorkshire) Area (GSP Group \_M)

Note: The list of MPANs / MSIDs provided may be incomplete; the DNO reserves the right to apply the listed charges to any other MPANs / MSIDs associated with the site.

### Southern Electric Power Distribution plc - Effective from 1 April 2027 - Final Schedule of Charges for use of the Distribution System by EHV Properties (including LDNOs with EHV Properties/end-users) in NPG Yorkshire Area (GSP Group \_M)

Time Periods for EHV Properties	
Time periods	Super Red Time Band
Monday to Friday (Including Bank Holidays) November to February Inclusive	1600 – 1930
Notes	All the above times are in UK Clock time

Import LLFC / DUoS Tariff ID	Import MPANs/MSIDs	Export LLFC / DUoS Tariff ID	Export MPANs/MSIDs	Tariff	Residual Charging Band	Import Super Red unit charge (p/kWh)	Import fixed charge (p/day)	Import capacity charge (p/kVA/day)	Import exceeded capacity charge (p/kVA/day)	Export Super Red unit charge (p/kWh)	Export fixed charge (p/day)	Export capacity charge (p/kVA/day)	Export exceeded capacity charge (p/kVA/day)

**Annex 3 - Schedule of Charges for use of the Distribution System to Preserved/Additional LLFC Classes in E&W**

Southern Electric Power Distribution plc - Effective from 1 April 2027 - Final LV and HV tariffs in E & W									
Supercustomer preserved charges / additional LLFCs / DUoS Tariff IDs									
	Closed LLFCs / DUoS Tariff IDs	PCs	Red/black unit charge p/kWh	Amber/yellow unit charge p/kWh	Green unit charge p/kWh	Fixed charge p/MPAN/day			
Notes:									

Site Specific preserved charges / additional LLFCs / DUoS Tariff IDs									
	Closed LLFCs / DUoS Tariff IDs	PCs	Red/black unit charge p/kWh	Amber/yellow unit charge p/kWh	Green unit charge p/kWh	Fixed charge p/MPAN/day	Capacity charge p/kVA/day	Exceeded capacity charge p/kVA/day	Reactive power charge p/kVArh
		0							
Notes:									

## Annex 4 - Charges applied to LDNOs with HV/LV end users in “Eastern Power Networks Area (GSP Group \_A)”

### Southern Electric Power Distribution plc - Effective from 1st April 2027 - Final LDNO tariffs in UKPN EPN Area (GSP Group \_A)

Time Bands for LV and HV Properties			
Time periods	Red Time Band	Amber Time Band	Green Time Band
Monday to Friday (Including Bank Holidays) All Year	16:00 - 19:00	07:00 - 16:00 19:00 - 23:00	00:00 - 07:00 23:00 - 24:00
Saturday and Sunday All Year			00:00 - 24:00
Notes	All times are in UK Clock time		

Time Bands for Unmetered Properties			
	Black Time Band	Yellow Time Band	Green Time Band
Monday to Friday (Including Bank Holidays) November to February Inclusive	16:00 - 19:00	07:00 - 16:00 19:00 - 23:00	00:00 - 07:00 23:00 - 24:00
Monday to Friday (Including Bank Holidays) March to October Inclusive		07:00 - 23:00	00:00 - 07:00 23:00 - 24:00
Saturday and Sunday All Year			00:00 - 24:00
Notes	All times are in UK Clock time		

Tariff name	Unique billing identifier	PCs	Red/black unit charge p/kWh	Amber/yellow unit charge p/kWh	Green unit charge p/kWh	Fixed charge p/MPAN/day	Capacity charge p/kVA/day	Exceeded capacity charge p/kVA/day	Reactive power charge p/kVArh
LDNO LV: Domestic Aggregated or CT with Residual		0, 1, 2	9.690	1.588	0.214	7.57			
LDNO LV: Domestic Aggregated (related MPAN)		2	9.690	1.588	0.214				
LDNO LV: Non-Domestic Aggregated or CT No Residual		0, 3, 4, 5-8	7.481	1.226	0.165	6.68			
LDNO LV: Non-Domestic Aggregated or CT Band 1		0, 3, 4, 5-8	7.481	1.226	0.165	7.94			
LDNO LV: Non-Domestic Aggregated or CT Band 2		0, 3, 4, 5-8	7.481	1.226	0.165	10.07			
LDNO LV: Non-Domestic Aggregated or CT Band 3		0, 3, 4, 5-8	7.481	1.226	0.165	13.44			
LDNO LV: Non-Domestic Aggregated or CT Band 4		0, 3, 4, 5-8	7.481	1.226	0.165	25.52			
LDNO LV: Non-Domestic Aggregated (related MPAN)		4	7.481	1.226	0.165				
LDNO LV: LV Site Specific No Residual		0	5.478	0.854	0.108	15.98	5.64	5.64	0.274
LDNO LV: LV Site Specific Band 1		0	5.478	0.854	0.108	55.87	5.64	5.64	0.274
LDNO LV: LV Site Specific Band 2		0	5.478	0.854	0.108	79.07	5.64	5.64	0.274
LDNO LV: LV Site Specific Band 3		0	5.478	0.854	0.108	111.45	5.64	5.64	0.274
LDNO LV: LV Site Specific Band 4		0	5.478	0.854	0.108	237.71	5.64	5.64	0.274

Tariff name	Unique billing identifier	PCs	Red/black unit charge p/kWh	Amber/yellow unit charge p/kWh	Green unit charge p/kWh	Fixed charge p/MPAN/day	Capacity charge p/kVA/day	Exceeded capacity charge p/kVA/day	Reactive power charge p/kVArh
LDNO LV: Unmetered Supplies		0, 1 or 8	28.539	2.940	1.705				
LDNO LV: LV Generation Aggregated		0, 8	-8.760	-1.435	-0.194	0.00			
LDNO LV: LV Generation Site Specific		0	-8.760	-1.435	-0.194	0.00			0.500
LDNO HV: Domestic Aggregated or CT with Residual		0, 1, 2	7.519	1.232	0.166	5.87			
LDNO HV: Domestic Aggregated (Related MPAN)		2	7.519	1.232	0.166				
LDNO HV: Non-Domestic Aggregated or CT No Residual		0, 3, 4, 5-8	5.805	0.951	0.128	5.18			
LDNO HV: Non-Domestic Aggregated or CT Band 1		0, 3, 4, 5-8	5.805	0.951	0.128	6.16			
LDNO HV: Non-Domestic Aggregated or CT Band 2		0, 3, 4, 5-8	5.805	0.951	0.128	7.81			
LDNO HV: Non-Domestic Aggregated or CT Band 3		0, 3, 4, 5-8	5.805	0.951	0.128	10.43			
LDNO HV: Non-Domestic Aggregated or CT Band 4		0, 3, 4, 5-8	5.805	0.951	0.128	19.81			
LDNO HV: Non-Domestic Aggregated (related MPAN)		4	5.805	0.951	0.128				
LDNO HV: LV Site Specific No Residual		0	4.251	0.663	0.084	12.40	4.38	4.38	0.213
LDNO HV: LV Site Specific Band 1		0	4.251	0.663	0.084	43.35	4.38	4.38	0.213
LDNO HV: LV Site Specific Band 2		0	4.251	0.663	0.084	61.35	4.38	4.38	0.213
LDNO HV: LV Site Specific Band 3		0	4.251	0.663	0.084	86.48	4.38	4.38	0.213
LDNO HV: LV Site Specific Band 4		0	4.251	0.663	0.084	184.45	4.38	4.38	0.213
LDNO HV: LV Sub Site Specific No Residual		0	4.272	0.612	0.068	16.48	5.02	5.02	0.197
LDNO HV: LV Sub Site Specific Band 1		0	4.272	0.612	0.068	65.36	5.02	5.02	0.197
LDNO HV: LV Sub Site Specific Band 2		0	4.272	0.612	0.068	93.79	5.02	5.02	0.197
LDNO HV: LV Sub Site Specific Band 3		0	4.272	0.612	0.068	133.48	5.02	5.02	0.197
LDNO HV: LV Sub Site Specific Band 4		0	4.272	0.612	0.068	288.20	5.02	5.02	0.197
LDNO HV: HV Site Specific No Residual		0	4.096	0.555	0.059	195.33	4.92	4.92	0.178
LDNO HV: HV Site Specific Band 1		0	4.096	0.555	0.059	673.78	4.92	4.92	0.178
LDNO HV: HV Site Specific Band 2		0	4.096	0.555	0.059	1216.62	4.92	4.92	0.178
LDNO HV: HV Site Specific Band 3		0	4.096	0.555	0.059	1998.85	4.92	4.92	0.178
LDNO HV: HV Site Specific Band 4		0	4.096	0.555	0.059	5459.35	4.92	4.92	0.178
LDNO HV: Unmetered Supplies		0, 1 or 8	22.145	2.282	1.323				
LDNO HV: LV Generation Aggregated		0, 8	-8.760	-1.435	-0.194	0.00			
LDNO HV: LV Sub Generation Aggregated		0	-6.988	-1.106	-0.143	0.00			
LDNO HV: LV Generation Site Specific		0	-8.760	-1.435	-0.194	0.00			0.500
LDNO HV: LV Sub Generation Site Specific		0	-6.988	-1.106	-0.143	0.00			0.354
LDNO HV: HV Generation Site Specific		0	-5.127	-0.735	-0.082	0.00			0.299

Tariff name	Unique billing identifier	PCs	Red/black unit charge p/kWh	Amber/yellow unit charge p/kWh	Green unit charge p/kWh	Fixed charge p/MPAN/day	Capacity charge p/kVA/day	Exceeded capacity charge p/kVA/day	Reactive power charge p/kVArh
LDNO HVplus: Domestic Aggregated or CT with Residual		0, 1, 2	6.515	1.068	0.144	5.09			
LDNO HVplus: Domestic Aggregated (related MPAN)		2	6.515	1.068	0.144				
LDNO HVplus: Non-Domestic Aggregated or CT No Residual		0, 3, 4, 5-8	5.030	0.824	0.111	4.49			
LDNO HVplus: Non-Domestic Aggregated or CT Band 1		0, 3, 4, 5-8	5.030	0.824	0.111	5.34			
LDNO HVplus: Non-Domestic Aggregated or CT Band 2		0, 3, 4, 5-8	5.030	0.824	0.111	6.77			
LDNO HVplus: Non-Domestic Aggregated or CT Band 3		0, 3, 4, 5-8	5.030	0.824	0.111	9.04			
LDNO HVplus: Non-Domestic Aggregated or CT Band 4		0, 3, 4, 5-8	5.030	0.824	0.111	17.16			
LDNO HVplus: Non-Domestic Aggregated (related MPAN)		4	5.030	0.824	0.111				
LDNO HVplus: LV Site Specific No Residual		0	3.683	0.574	0.073	10.75	3.80	3.80	0.184
LDNO HVplus: LV Site Specific Band 1		0	3.683	0.574	0.073	37.57	3.80	3.80	0.184
LDNO HVplus: LV Site Specific Band 2		0	3.683	0.574	0.073	53.16	3.80	3.80	0.184
LDNO HVplus: LV Site Specific Band 3		0	3.683	0.574	0.073	74.94	3.80	3.80	0.184
LDNO HVplus: LV Site Specific Band 4		0	3.683	0.574	0.073	159.83	3.80	3.80	0.184
LDNO HVplus: LV Sub Site Specific No Residual		0	3.602	0.516	0.057	13.90	4.23	4.23	0.166
LDNO HVplus: LV Sub Site Specific Band 1		0	3.602	0.516	0.057	55.11	4.23	4.23	0.166
LDNO HVplus: LV Sub Site Specific Band 2		0	3.602	0.516	0.057	79.08	4.23	4.23	0.166
LDNO HVplus: LV Sub Site Specific Band 3		0	3.602	0.516	0.057	112.54	4.23	4.23	0.166
LDNO HVplus: LV Sub Site Specific Band 4		0	3.602	0.516	0.057	243.00	4.23	4.23	0.166
LDNO HVplus: HV Site Specific No Residual		0	3.412	0.463	0.049	162.73	4.10	4.10	0.148
LDNO HVplus: HV Site Specific Band 1		0	3.412	0.463	0.049	561.33	4.10	4.10	0.148
LDNO HVplus: HV Site Specific Band 2		0	3.412	0.463	0.049	1013.57	4.10	4.10	0.148
LDNO HVplus: HV Site Specific Band 3		0	3.412	0.463	0.049	1665.25	4.10	4.10	0.148
LDNO HVplus: HV Site Specific Band 4		0	3.412	0.463	0.049	4548.21	4.10	4.10	0.148
LDNO HVplus: Unmetered Supplies		0, 1 or 8	19.189	1.977	1.146				
LDNO HVplus: LV Generation Aggregated		0, 8	-5.814	-0.953	-0.128	0.00			
LDNO HVplus: LV Sub Generation Aggregated		0	-5.122	-0.810	-0.105	0.00			
LDNO HVplus: LV Generation Site Specific		0	-5.814	-0.953	-0.128	0.00			0.332
LDNO HVplus: LV Sub Generation Site Specific		0	-5.122	-0.810	-0.105	0.00			0.259
LDNO HVplus: HV Generation Site Specific		0	-5.127	-0.735	-0.082	15.58			0.299
LDNO EHV: Domestic Aggregated or CT with Residual		0, 1, 2	5.004	0.820	0.111	3.91			

Tariff name	Unique billing identifier	PCs	Red/black unit charge p/kWh	Amber/yellow unit charge p/kWh	Green unit charge p/kWh	Fixed charge p/MPAN/day	Capacity charge p/kVA/day	Exceeded capacity charge p/kVA/day	Reactive power charge p/kVArh
LDNO EHV: Domestic Aggregated (related MPAN)		2	5.004	0.820	0.111				
LDNO EHV: Non-Domestic Aggregated or CT No Residual		0, 3, 4, 5-8	3.863	0.633	0.085	3.45			
LDNO EHV: Non-Domestic Aggregated or CT Band 1		0, 3, 4, 5-8	3.863	0.633	0.085	4.10			
LDNO EHV: Non-Domestic Aggregated or CT Band 2		0, 3, 4, 5-8	3.863	0.633	0.085	5.20			
LDNO EHV: Non-Domestic Aggregated or CT Band 3		0, 3, 4, 5-8	3.863	0.633	0.085	6.94			
LDNO EHV: Non-Domestic Aggregated or CT Band 4		0, 3, 4, 5-8	3.863	0.633	0.085	13.18			
LDNO EHV: Non-Domestic Aggregated (related MPAN)		4	3.863	0.633	0.085				
LDNO EHV: LV Site Specific No Residual		0	2.829	0.441	0.056	8.25	2.91	2.91	0.142
LDNO EHV: LV Site Specific Band 1		0	2.829	0.441	0.056	28.85	2.91	2.91	0.142
LDNO EHV: LV Site Specific Band 2		0	2.829	0.441	0.056	40.83	2.91	2.91	0.142
LDNO EHV: LV Site Specific Band 3		0	2.829	0.441	0.056	57.55	2.91	2.91	0.142
LDNO EHV: LV Site Specific Band 4		0	2.829	0.441	0.056	122.75	2.91	2.91	0.142
LDNO EHV: LV Sub Site Specific No Residual		0	2.766	0.396	0.044	10.67	3.25	3.25	0.127
LDNO EHV: LV Sub Site Specific Band 1		0	2.766	0.396	0.044	42.33	3.25	3.25	0.127
LDNO EHV: LV Sub Site Specific Band 2		0	2.766	0.396	0.044	60.73	3.25	3.25	0.127
LDNO EHV: LV Sub Site Specific Band 3		0	2.766	0.396	0.044	86.43	3.25	3.25	0.127
LDNO EHV: LV Sub Site Specific Band 4		0	2.766	0.396	0.044	186.62	3.25	3.25	0.127
LDNO EHV: HV Site Specific No Residual		0	2.621	0.355	0.037	124.97	3.15	3.15	0.114
LDNO EHV: HV Site Specific Band 1		0	2.621	0.355	0.037	431.10	3.15	3.15	0.114
LDNO EHV: HV Site Specific Band 2		0	2.621	0.355	0.037	778.41	3.15	3.15	0.114
LDNO EHV: HV Site Specific Band 3		0	2.621	0.355	0.037	1278.90	3.15	3.15	0.114
LDNO EHV: HV Site Specific Band 4		0	2.621	0.355	0.037	3492.99	3.15	3.15	0.114
LDNO EHV: Unmetered Supplies		0, 1 or 8	14.737	1.518	0.880				
LDNO EHV: LV Generation Aggregated		0, 8	-4.465	-0.732	-0.099	0.00			
LDNO EHV: LV Sub Generation Aggregated		0	-3.933	-0.622	-0.080	0.00			
LDNO EHV: LV Generation Site Specific		0	-4.465	-0.732	-0.099	0.00			0.255
LDNO EHV: LV Sub Generation Site Specific		0	-3.933	-0.622	-0.080	0.00			0.199
LDNO EHV: HV Generation Site Specific		0	-3.938	-0.564	-0.063	11.97			0.230
LDNO 132kV/EHV: Domestic Aggregated or CT with Residual		0, 1, 2	3.778	0.619	0.084	2.95			
LDNO 132kV/EHV: Domestic Aggregated (related MPAN)		2	3.778	0.619	0.084				

Tariff name	Unique billing identifier	PCs	Red/black unit charge p/kWh	Amber/yellow unit charge p/kWh	Green unit charge p/kWh	Fixed charge p/MPAN/day	Capacity charge p/kVA/day	Exceeded capacity charge p/kVA/day	Reactive power charge p/kVArh
LDNO 132kV/EHV: Non-Domestic Aggregated or CT No Residual		0, 3, 4, 5-8	2.917	0.478	0.064	2.61			
LDNO 132kV/EHV: Non-Domestic Aggregated or CT Band 1		0, 3, 4, 5-8	2.917	0.478	0.064	3.10			
LDNO 132kV/EHV: Non-Domestic Aggregated or CT Band 2		0, 3, 4, 5-8	2.917	0.478	0.064	3.92			
LDNO 132kV/EHV: Non-Domestic Aggregated or CT Band 3		0, 3, 4, 5-8	2.917	0.478	0.064	5.24			
LDNO 132kV/EHV: Non-Domestic Aggregated or CT Band 4		0, 3, 4, 5-8	2.917	0.478	0.064	9.95			
LDNO 132kV/EHV: Non-Domestic Aggregated (related MPAN)		4	2.917	0.478	0.064				
LDNO 132kV/EHV: LV Site Specific No Residual		0	2.136	0.333	0.042	6.23	2.20	2.20	0.107
LDNO 132kV/EHV: LV Site Specific Band 1		0	2.136	0.333	0.042	21.78	2.20	2.20	0.107
LDNO 132kV/EHV: LV Site Specific Band 2		0	2.136	0.333	0.042	30.83	2.20	2.20	0.107
LDNO 132kV/EHV: LV Site Specific Band 3		0	2.136	0.333	0.042	43.45	2.20	2.20	0.107
LDNO 132kV/EHV: LV Site Specific Band 4		0	2.136	0.333	0.042	92.68	2.20	2.20	0.107
LDNO 132kV/EHV: LV Sub Site Specific No Residual		0	2.089	0.299	0.033	8.06	2.45	2.45	0.096
LDNO 132kV/EHV: LV Sub Site Specific Band 1		0	2.089	0.299	0.033	31.96	2.45	2.45	0.096
LDNO 132kV/EHV: LV Sub Site Specific Band 2		0	2.089	0.299	0.033	45.86	2.45	2.45	0.096
LDNO 132kV/EHV: LV Sub Site Specific Band 3		0	2.089	0.299	0.033	65.26	2.45	2.45	0.096
LDNO 132kV/EHV: LV Sub Site Specific Band 4		0	2.089	0.299	0.033	140.91	2.45	2.45	0.096
LDNO 132kV/EHV: HV Site Specific No Residual		0	1.979	0.268	0.028	94.36	2.38	2.38	0.086
LDNO 132kV/EHV: HV Site Specific Band 1		0	1.979	0.268	0.028	325.50	2.38	2.38	0.086
LDNO 132kV/EHV: HV Site Specific Band 2		0	1.979	0.268	0.028	587.74	2.38	2.38	0.086
LDNO 132kV/EHV: HV Site Specific Band 3		0	1.979	0.268	0.028	965.63	2.38	2.38	0.086
LDNO 132kV/EHV: HV Site Specific Band 4		0	1.979	0.268	0.028	2637.37	2.38	2.38	0.086
LDNO 132kV/EHV: Unmetered Supplies		0, 1 or 8	11.127	1.146	0.665				
LDNO 132kV/EHV: LV Generation Aggregated		0, 8	-3.371	-0.552	-0.075	0.00			
LDNO 132kV/EHV: LV Sub Generation Aggregated		0	-2.970	-0.470	-0.061	0.00			
LDNO 132kV/EHV: LV Generation Site Specific		0	-3.371	-0.552	-0.075	0.00			0.192
LDNO 132kV/EHV: LV Sub Generation Site Specific		0	-2.970	-0.470	-0.061	0.00			0.150
LDNO 132kV/EHV: HV Generation Site Specific		0	-2.973	-0.426	-0.047	9.04			0.173
LDNO 132kV: Domestic Aggregated or CT with Residual		0, 1, 2	2.581	0.423	0.057	2.02			
LDNO 132kV: Domestic Aggregated (related MPAN)		2	2.581	0.423	0.057				

Tariff name	Unique billing identifier	PCs	Red/black unit charge p/kWh	Amber/yellow unit charge p/kWh	Green unit charge p/kWh	Fixed charge p/MPAN/day	Capacity charge p/kVA/day	Exceeded capacity charge p/kVA/day	Reactive power charge p/kVArh
LDNO 132kV: Non-Domestic Aggregated or CT No Residual		0, 3, 4, 5-8	1.993	0.326	0.044	1.78			
LDNO 132kV: Non-Domestic Aggregated or CT Band 1		0, 3, 4, 5-8	1.993	0.326	0.044	2.12			
LDNO 132kV: Non-Domestic Aggregated or CT Band 2		0, 3, 4, 5-8	1.993	0.326	0.044	2.68			
LDNO 132kV: Non-Domestic Aggregated or CT Band 3		0, 3, 4, 5-8	1.993	0.326	0.044	3.58			
LDNO 132kV: Non-Domestic Aggregated or CT Band 4		0, 3, 4, 5-8	1.993	0.326	0.044	6.80			
LDNO 132kV: Non-Domestic Aggregated (related MPAN)		4	1.993	0.326	0.044				
LDNO 132kV: LV Site Specific No Residual		0	1.459	0.227	0.029	4.26	1.50	1.50	0.073
LDNO 132kV: LV Site Specific Band 1		0	1.459	0.227	0.029	14.88	1.50	1.50	0.073
LDNO 132kV: LV Site Specific Band 2		0	1.459	0.227	0.029	21.06	1.50	1.50	0.073
LDNO 132kV: LV Site Specific Band 3		0	1.459	0.227	0.029	29.68	1.50	1.50	0.073
LDNO 132kV: LV Site Specific Band 4		0	1.459	0.227	0.029	63.31	1.50	1.50	0.073
LDNO 132kV: LV Sub Site Specific No Residual		0	1.427	0.204	0.023	5.50	1.68	1.68	0.066
LDNO 132kV: LV Sub Site Specific Band 1		0	1.427	0.204	0.023	21.83	1.68	1.68	0.066
LDNO 132kV: LV Sub Site Specific Band 2		0	1.427	0.204	0.023	31.32	1.68	1.68	0.066
LDNO 132kV: LV Sub Site Specific Band 3		0	1.427	0.204	0.023	44.58	1.68	1.68	0.066
LDNO 132kV: LV Sub Site Specific Band 4		0	1.427	0.204	0.023	96.25	1.68	1.68	0.066
LDNO 132kV: HV Site Specific No Residual		0	1.352	0.183	0.019	64.46	1.62	1.62	0.059
LDNO 132kV: HV Site Specific Band 1		0	1.352	0.183	0.019	222.35	1.62	1.62	0.059
LDNO 132kV: HV Site Specific Band 2		0	1.352	0.183	0.019	401.49	1.62	1.62	0.059
LDNO 132kV: HV Site Specific Band 3		0	1.352	0.183	0.019	659.62	1.62	1.62	0.059
LDNO 132kV: HV Site Specific Band 4		0	1.352	0.183	0.019	1801.60	1.62	1.62	0.059
LDNO 132kV: Unmetered Supplies		0, 1 or 8	7.601	0.783	0.454				
LDNO 132kV: LV Generation Aggregated		0, 8	-2.303	-0.377	-0.051	0.00			
LDNO 132kV: LV Sub Generation Aggregated		0	-2.029	-0.321	-0.041	0.00			
LDNO 132kV: LV Generation Site Specific		0	-2.303	-0.377	-0.051	0.00			0.131
LDNO 132kV: LV Sub Generation Site Specific		0	-2.029	-0.321	-0.041	0.00			0.103
LDNO 132kV: HV Generation Site Specific		0	-2.031	-0.291	-0.032	6.17			0.118
LDNO 0000: Domestic Aggregated or CT with Residual		0, 1, 2	0.672	0.110	0.015	0.52			
LDNO 0000: Domestic Aggregated (related MPAN)		2	0.672	0.110	0.015				
LDNO 0000: Non-Domestic Aggregated or CT No Residual		0, 3, 4, 5-8	0.519	0.085	0.011	0.46			
LDNO 0000: Non-Domestic Aggregated or CT Band 1		0, 3, 4, 5-8	0.519	0.085	0.011	0.55			

Tariff name	Unique billing identifier	PCs	Red/black unit charge p/kWh	Amber/yellow unit charge p/kWh	Green unit charge p/kWh	Fixed charge p/MPAN/day	Capacity charge p/kVA/day	Exceeded capacity charge p/kVA/day	Reactive power charge p/kVArh
LDNO 0000: Non-Domestic Aggregated or CT Band 2		0, 3, 4, 5-8	0.519	0.085	0.011	0.70			
LDNO 0000: Non-Domestic Aggregated or CT Band 3		0, 3, 4, 5-8	0.519	0.085	0.011	0.93			
LDNO 0000: Non-Domestic Aggregated or CT Band 4		0, 3, 4, 5-8	0.519	0.085	0.011	1.77			
LDNO 0000: Non-Domestic Aggregated (related MPAN)		4	0.519	0.085	0.011				
LDNO 0000: LV Site Specific No Residual		0	0.380	0.059	0.007	1.11	0.39	0.39	0.019
LDNO 0000: LV Site Specific Band 1		0	0.380	0.059	0.007	3.87	0.39	0.39	0.019
LDNO 0000: LV Site Specific Band 2		0	0.380	0.059	0.007	5.48	0.39	0.39	0.019
LDNO 0000: LV Site Specific Band 3		0	0.380	0.059	0.007	7.73	0.39	0.39	0.019
LDNO 0000: LV Site Specific Band 4		0	0.380	0.059	0.007	16.48	0.39	0.39	0.019
LDNO 0000: LV Sub Site Specific No Residual		0	0.371	0.053	0.006	1.43	0.44	0.44	0.017
LDNO 0000: LV Sub Site Specific Band 1		0	0.371	0.053	0.006	5.68	0.44	0.44	0.017
LDNO 0000: LV Sub Site Specific Band 2		0	0.371	0.053	0.006	8.15	0.44	0.44	0.017
LDNO 0000: LV Sub Site Specific Band 3		0	0.371	0.053	0.006	11.60	0.44	0.44	0.017
LDNO 0000: LV Sub Site Specific Band 4		0	0.371	0.053	0.006	25.06	0.44	0.44	0.017
LDNO 0000: HV Site Specific No Residual		0	0.352	0.048	0.005	16.78	0.42	0.42	0.015
LDNO 0000: HV Site Specific Band 1		0	0.352	0.048	0.005	57.88	0.42	0.42	0.015
LDNO 0000: HV Site Specific Band 2		0	0.352	0.048	0.005	104.51	0.42	0.42	0.015
LDNO 0000: HV Site Specific Band 3		0	0.352	0.048	0.005	171.71	0.42	0.42	0.015
LDNO 0000: HV Site Specific Band 4		0	0.352	0.048	0.005	468.98	0.42	0.42	0.015
LDNO 0000: Unmetered Supplies		0, 1 or 8	1.979	0.204	0.118				
LDNO 0000: LV Generation Aggregated		0, 8	-0.599	-0.098	-0.013	0.00			
LDNO 0000: LV Sub Generation Aggregated		0	-0.528	-0.084	-0.011	0.00			
LDNO 0000: LV Generation Site Specific		0	-0.599	-0.098	-0.013	0.00			0.034
LDNO 0000: LV Sub Generation Site Specific		0	-0.528	-0.084	-0.011	0.00			0.027
LDNO 0000: HV Generation Site Specific		0	-0.529	-0.076	-0.008	1.61			0.031

## Annex 4 - Charges applied to LDNOs with HV/LV end users in “NGED East Midlands Area (GSP Group \_B)”

### Southern Electric Power Distribution plc - Effective from 1st April 2027 - Final LDNO tariffs in NGED EM Area (GSP Group \_B)

Time Bands for LV and HV Properties			
Time periods	Red Time Band	Amber Time Band	Green Time Band
Monday to Friday (Including Bank Holidays) All Year	16:00 to 19:00	07:30 to 16:00 19:00 to 21:00	00:00 to 07:30 21:00 to 24:00
Saturday and Sunday All Year			00:00 to 24:00
Notes	All the above times are in UK Clock time		

Time Bands for Unmetered Properties			
	Black Time Band	Yellow Time Band	Green Time Band
Monday to Friday (Including Bank Holidays) Nov to Feb Inclusive	16:00 to 19:00	07:30 to 16:00 19:00 to 21:00	00:00 to 07:30 21:00 to 24:00
Monday to Friday (Including Bank Holidays) Mar to Oct Inclusive		07:30 to 21:00	00:00 to 07:30 21:00 to 24:00
Saturday and Sunday All Year			00:00 to 24:00
Notes	All the above times are in UK Clock time		

Tariff name	Unique billing identifier	PCs	Red/black unit charge p/kWh	Amber/yellow unit charge p/kWh	Green unit charge p/kWh	Fixed charge p/MPAN/day	Capacity charge p/kVA/day	Exceeded capacity charge p/kVA/day	Reactive power charge p/kVArh
LDNO LV: Domestic Aggregated or CT with Residual		0, 1, 2	8.392	1.001	0.082	8.08			
LDNO LV: Domestic Aggregated (related MPAN)		2	8.392	1.001	0.082				
LDNO LV: Non-Domestic Aggregated or CT No Residual		0, 3, 4, 5-8	8.125	0.969	0.080	7.98			
LDNO LV: Non-Domestic Aggregated or CT Band 1		0, 3, 4, 5-8	8.125	0.969	0.080	10.14			
LDNO LV: Non-Domestic Aggregated or CT Band 2		0, 3, 4, 5-8	8.125	0.969	0.080	16.14			
LDNO LV: Non-Domestic Aggregated or CT Band 3		0, 3, 4, 5-8	8.125	0.969	0.080	25.88			
LDNO LV: Non-Domestic Aggregated or CT Band 4		0, 3, 4, 5-8	8.125	0.969	0.080	54.99			
LDNO LV: Non-Domestic Aggregated (related MPAN)		4	8.125	0.969	0.080				
LDNO LV: LV Site Specific No Residual		0	5.505	0.615	0.047	9.39	5.18	5.18	0.163
LDNO LV: LV Site Specific Band 1		0	5.505	0.615	0.047	91.88	5.18	5.18	0.163
LDNO LV: LV Site Specific Band 2		0	5.505	0.615	0.047	149.15	5.18	5.18	0.163
LDNO LV: LV Site Specific Band 3		0	5.505	0.615	0.047	234.30	5.18	5.18	0.163

Tariff name	Unique billing identifier	PCs	Red/black unit charge p/kWh	Amber/yellow unit charge p/kWh	Green unit charge p/kWh	Fixed charge p/MPAN/day	Capacity charge p/kVA/day	Exceeded capacity charge p/kVA/day	Reactive power charge p/kVArh
LDNO LV: LV Site Specific Band 4		0	5.505	0.615	0.047	461.44	5.18	5.18	0.163
LDNO LV: Unmetered Supplies		0, 1 or 8	26.076	1.947	1.090				
LDNO LV: LV Generation Aggregated		0	-8.040	-0.959	-0.079	0.00			
LDNO LV: LV Generation Site Specific		0	-8.040	-0.959	-0.079	0.00			0.280
LDNO HV: Domestic Aggregated or CT with Residual		0, 1, 2	6.638	0.792	0.065	6.39			
LDNO HV: Domestic Aggregated (Related MPAN)		2	6.638	0.792	0.065				
LDNO HV: Non-Domestic Aggregated or CT No Residual		0, 3, 4, 5-8	6.426	0.766	0.063	6.31			
LDNO HV: Non-Domestic Aggregated or CT Band 1		0, 3, 4, 5-8	6.426	0.766	0.063	8.02			
LDNO HV: Non-Domestic Aggregated or CT Band 2		0, 3, 4, 5-8	6.426	0.766	0.063	12.76			
LDNO HV: Non-Domestic Aggregated or CT Band 3		0, 3, 4, 5-8	6.426	0.766	0.063	20.47			
LDNO HV: Non-Domestic Aggregated or CT Band 4		0, 3, 4, 5-8	6.426	0.766	0.063	43.49			
LDNO HV: Non-Domestic Aggregated (related MPAN)		4	6.426	0.766	0.063				
LDNO HV: LV Site Specific No Residual		0	4.354	0.487	0.038	7.43	4.10	4.10	0.129
LDNO HV: LV Site Specific Band 1		0	4.354	0.487	0.038	72.67	4.10	4.10	0.129
LDNO HV: LV Site Specific Band 2		0	4.354	0.487	0.038	117.96	4.10	4.10	0.129
LDNO HV: LV Site Specific Band 3		0	4.354	0.487	0.038	185.31	4.10	4.10	0.129
LDNO HV: LV Site Specific Band 4		0	4.354	0.487	0.038	364.96	4.10	4.10	0.129
LDNO HV: LV Sub Site Specific No Residual		0	4.441	0.422	0.026	8.98	6.15	6.15	0.125
LDNO HV: LV Sub Site Specific Band 1		0	4.441	0.422	0.026	110.09	6.15	6.15	0.125
LDNO HV: LV Sub Site Specific Band 2		0	4.441	0.422	0.026	180.28	6.15	6.15	0.125
LDNO HV: LV Sub Site Specific Band 3		0	4.441	0.422	0.026	284.64	6.15	6.15	0.125
LDNO HV: LV Sub Site Specific Band 4		0	4.441	0.422	0.026	563.04	6.15	6.15	0.125
LDNO HV: HV Site Specific No Residual		0	2.865	0.214	0.008	94.32	8.09	8.09	0.071
LDNO HV: HV Site Specific Band 1		0	2.865	0.214	0.008	873.34	8.09	8.09	0.071
LDNO HV: HV Site Specific Band 2		0	2.865	0.214	0.008	2370.45	8.09	8.09	0.071
LDNO HV: HV Site Specific Band 3		0	2.865	0.214	0.008	4309.77	8.09	8.09	0.071
LDNO HV: HV Site Specific Band 4		0	2.865	0.214	0.008	10806.97	8.09	8.09	0.071
LDNO HV: Unmetered Supplies		0, 1 or 8	20.624	1.540	0.862				
LDNO HV: LV Generation Aggregated		0	-8.040	-0.959	-0.079	0.00			
LDNO HV: LV Sub Generation Aggregated		0	-6.716	-0.769	-0.061	0.00			
LDNO HV: LV Generation Site Specific		0	-8.040	-0.959	-0.079	0.00			0.280
LDNO HV: LV Sub Generation Site Specific		0	-6.716	-0.769	-0.061	0.00			0.209
LDNO HV: HV Generation Site Specific		0	-4.189	-0.398	-0.025	0.00			0.173

Tariff name	Unique billing identifier	PCs	Red/black unit charge p/kWh	Amber/yellow unit charge p/kWh	Green unit charge p/kWh	Fixed charge p/MPAN/day	Capacity charge p/kVA/day	Exceeded capacity charge p/kVA/day	Reactive power charge p/kVArh
LDNO HVplus: Domestic Aggregated or CT with Residual		0, 1, 2	5.230	0.624	0.051	5.03			
LDNO HVplus: Domestic Aggregated (related MPAN)		2	5.230	0.624	0.051				
LDNO HVplus: Non-Domestic Aggregated or CT No Residual		0, 3, 4, 5-8	5.064	0.604	0.050	4.97			
LDNO HVplus: Non-Domestic Aggregated or CT Band 1		0, 3, 4, 5-8	5.064	0.604	0.050	6.32			
LDNO HVplus: Non-Domestic Aggregated or CT Band 2		0, 3, 4, 5-8	5.064	0.604	0.050	10.06			
LDNO HVplus: Non-Domestic Aggregated or CT Band 3		0, 3, 4, 5-8	5.064	0.604	0.050	16.13			
LDNO HVplus: Non-Domestic Aggregated or CT Band 4		0, 3, 4, 5-8	5.064	0.604	0.050	34.27			
LDNO HVplus: Non-Domestic Aggregated (related MPAN)		4	5.064	0.604	0.050				
LDNO HVplus: LV Site Specific No Residual		0	3.431	0.384	0.030	5.85	3.23	3.23	0.101
LDNO HVplus: LV Site Specific Band 1		0	3.431	0.384	0.030	57.26	3.23	3.23	0.101
LDNO HVplus: LV Site Specific Band 2		0	3.431	0.384	0.030	92.96	3.23	3.23	0.101
LDNO HVplus: LV Site Specific Band 3		0	3.431	0.384	0.030	146.02	3.23	3.23	0.101
LDNO HVplus: LV Site Specific Band 4		0	3.431	0.384	0.030	287.59	3.23	3.23	0.101
LDNO HVplus: LV Sub Site Specific No Residual		0	3.406	0.324	0.020	6.89	4.71	4.71	0.096
LDNO HVplus: LV Sub Site Specific Band 1		0	3.406	0.324	0.020	84.43	4.71	4.71	0.096
LDNO HVplus: LV Sub Site Specific Band 2		0	3.406	0.324	0.020	138.26	4.71	4.71	0.096
LDNO HVplus: LV Sub Site Specific Band 3		0	3.406	0.324	0.020	218.30	4.71	4.71	0.096
LDNO HVplus: LV Sub Site Specific Band 4		0	3.406	0.324	0.020	431.81	4.71	4.71	0.096
LDNO HVplus: HV Site Specific No Residual		0	2.167	0.162	0.006	71.34	6.12	6.12	0.054
LDNO HVplus: HV Site Specific Band 1		0	2.167	0.162	0.006	660.56	6.12	6.12	0.054
LDNO HVplus: HV Site Specific Band 2		0	2.167	0.162	0.006	1792.92	6.12	6.12	0.054
LDNO HVplus: HV Site Specific Band 3		0	2.167	0.162	0.006	3259.75	6.12	6.12	0.054
LDNO HVplus: HV Site Specific Band 4		0	2.167	0.162	0.006	8174.00	6.12	6.12	0.054
LDNO HVplus: Unmetered Supplies		0, 1 or 8	16.252	1.214	0.679				
LDNO HVplus: LV Generation Aggregated		0	-4.972	-0.593	-0.049	0.00			
LDNO HVplus: LV Sub Generation Aggregated		0	-4.658	-0.533	-0.042	0.00			
LDNO HVplus: LV Generation Site Specific		0	-4.972	-0.593	-0.049	0.00			0.173
LDNO HVplus: LV Sub Generation Site Specific		0	-4.658	-0.533	-0.042	0.00			0.145
LDNO HVplus: HV Generation Site Specific		0	-4.189	-0.398	-0.025	64.37			0.173

Tariff name	Unique billing identifier	PCs	Red/black unit charge p/kWh	Amber/yellow unit charge p/kWh	Green unit charge p/kWh	Fixed charge p/MPAN/day	Capacity charge p/kVA/day	Exceeded capacity charge p/kVA/day	Reactive power charge p/kVArh
LDNO EHV: Domestic Aggregated or CT with Residual		0, 1, 2	4.544	0.542	0.045	4.37			
LDNO EHV: Domestic Aggregated (related MPAN)		2	4.544	0.542	0.045				
LDNO EHV: Non-Domestic Aggregated or CT No Residual		0, 3, 4, 5-8	4.399	0.525	0.043	4.32			
LDNO EHV: Non-Domestic Aggregated or CT Band 1		0, 3, 4, 5-8	4.399	0.525	0.043	5.49			
LDNO EHV: Non-Domestic Aggregated or CT Band 2		0, 3, 4, 5-8	4.399	0.525	0.043	8.74			
LDNO EHV: Non-Domestic Aggregated or CT Band 3		0, 3, 4, 5-8	4.399	0.525	0.043	14.01			
LDNO EHV: Non-Domestic Aggregated or CT Band 4		0, 3, 4, 5-8	4.399	0.525	0.043	29.77			
LDNO EHV: Non-Domestic Aggregated (related MPAN)		4	4.399	0.525	0.043				
LDNO EHV: LV Site Specific No Residual		0	2.981	0.333	0.026	5.08	2.81	2.81	0.088
LDNO EHV: LV Site Specific Band 1		0	2.981	0.333	0.026	49.74	2.81	2.81	0.088
LDNO EHV: LV Site Specific Band 2		0	2.981	0.333	0.026	80.75	2.81	2.81	0.088
LDNO EHV: LV Site Specific Band 3		0	2.981	0.333	0.026	126.85	2.81	2.81	0.088
LDNO EHV: LV Site Specific Band 4		0	2.981	0.333	0.026	249.82	2.81	2.81	0.088
LDNO EHV: LV Sub Site Specific No Residual		0	2.958	0.281	0.018	5.99	4.09	4.09	0.084
LDNO EHV: LV Sub Site Specific Band 1		0	2.958	0.281	0.018	73.34	4.09	4.09	0.084
LDNO EHV: LV Sub Site Specific Band 2		0	2.958	0.281	0.018	120.11	4.09	4.09	0.084
LDNO EHV: LV Sub Site Specific Band 3		0	2.958	0.281	0.018	189.63	4.09	4.09	0.084
LDNO EHV: LV Sub Site Specific Band 4		0	2.958	0.281	0.018	375.11	4.09	4.09	0.084
LDNO EHV: HV Site Specific No Residual		0	1.883	0.140	0.005	61.97	5.32	5.32	0.047
LDNO EHV: HV Site Specific Band 1		0	1.883	0.140	0.005	573.82	5.32	5.32	0.047
LDNO EHV: HV Site Specific Band 2		0	1.883	0.140	0.005	1557.49	5.32	5.32	0.047
LDNO EHV: HV Site Specific Band 3		0	1.883	0.140	0.005	2831.70	5.32	5.32	0.047
LDNO EHV: HV Site Specific Band 4		0	1.883	0.140	0.005	7100.64	5.32	5.32	0.047
LDNO EHV: Unmetered Supplies		0, 1 or 8	14.118	1.054	0.590				
LDNO EHV: LV Generation Aggregated		0	-4.319	-0.515	-0.042	0.00			
LDNO EHV: LV Sub Generation Aggregated		0	-4.046	-0.463	-0.037	0.00			
LDNO EHV: LV Generation Site Specific		0	-4.319	-0.515	-0.042	0.00			0.151
LDNO EHV: LV Sub Generation Site Specific		0	-4.046	-0.463	-0.037	0.00			0.126
LDNO EHV: HV Generation Site Specific		0	-3.639	-0.346	-0.022	55.92			0.150
LDNO 132kV/EHV: Domestic Aggregated or CT with Residual		0, 1, 2	4.245	0.506	0.042	4.09			
LDNO 132kV/EHV: Domestic Aggregated (related MPAN)		2	4.245	0.506	0.042				

Tariff name	Unique billing identifier	PCs	Red/black unit charge p/kWh	Amber/yellow unit charge p/kWh	Green unit charge p/kWh	Fixed charge p/MPAN/day	Capacity charge p/kVA/day	Exceeded capacity charge p/kVA/day	Reactive power charge p/kVArh
LDNO 132kV/EHV: Non-Domestic Aggregated or CT No Residual		0, 3, 4, 5-8	4.110	0.490	0.040	4.04			
LDNO 132kV/EHV: Non-Domestic Aggregated or CT Band 1		0, 3, 4, 5-8	4.110	0.490	0.040	5.13			
LDNO 132kV/EHV: Non-Domestic Aggregated or CT Band 2		0, 3, 4, 5-8	4.110	0.490	0.040	8.16			
LDNO 132kV/EHV: Non-Domestic Aggregated or CT Band 3		0, 3, 4, 5-8	4.110	0.490	0.040	13.09			
LDNO 132kV/EHV: Non-Domestic Aggregated or CT Band 4		0, 3, 4, 5-8	4.110	0.490	0.040	27.82			
LDNO 132kV/EHV: Non-Domestic Aggregated (related MPAN)		4	4.110	0.490	0.040				
LDNO 132kV/EHV: LV Site Specific No Residual		0	2.785	0.311	0.024	4.75	2.62	2.62	0.082
LDNO 132kV/EHV: LV Site Specific Band 1		0	2.785	0.311	0.024	46.48	2.62	2.62	0.082
LDNO 132kV/EHV: LV Site Specific Band 2		0	2.785	0.311	0.024	75.45	2.62	2.62	0.082
LDNO 132kV/EHV: LV Site Specific Band 3		0	2.785	0.311	0.024	118.52	2.62	2.62	0.082
LDNO 132kV/EHV: LV Site Specific Band 4		0	2.785	0.311	0.024	233.43	2.62	2.62	0.082
LDNO 132kV/EHV: LV Sub Site Specific No Residual		0	2.764	0.263	0.016	5.59	3.83	3.83	0.078
LDNO 132kV/EHV: LV Sub Site Specific Band 1		0	2.764	0.263	0.016	68.53	3.83	3.83	0.078
LDNO 132kV/EHV: LV Sub Site Specific Band 2		0	2.764	0.263	0.016	112.22	3.83	3.83	0.078
LDNO 132kV/EHV: LV Sub Site Specific Band 3		0	2.764	0.263	0.016	177.18	3.83	3.83	0.078
LDNO 132kV/EHV: LV Sub Site Specific Band 4		0	2.764	0.263	0.016	350.49	3.83	3.83	0.078
LDNO 132kV/EHV: HV Site Specific No Residual		0	1.759	0.131	0.005	57.90	4.97	4.97	0.044
LDNO 132kV/EHV: HV Site Specific Band 1		0	1.759	0.131	0.005	536.15	4.97	4.97	0.044
LDNO 132kV/EHV: HV Site Specific Band 2		0	1.759	0.131	0.005	1455.25	4.97	4.97	0.044
LDNO 132kV/EHV: HV Site Specific Band 3		0	1.759	0.131	0.005	2645.82	4.97	4.97	0.044
LDNO 132kV/EHV: HV Site Specific Band 4		0	1.759	0.131	0.005	6634.53	4.97	4.97	0.044
LDNO 132kV/EHV: Unmetered Supplies		0, 1 or 8	13.191	0.985	0.551				
LDNO 132kV/EHV: LV Generation Aggregated		0	-4.036	-0.481	-0.040	0.00			
LDNO 132kV/EHV: LV Sub Generation Aggregated		0	-3.780	-0.433	-0.034	0.00			
LDNO 132kV/EHV: LV Generation Site Specific		0	-4.036	-0.481	-0.040	0.00			0.141
LDNO 132kV/EHV: LV Sub Generation Site Specific		0	-3.780	-0.433	-0.034	0.00			0.117
LDNO 132kV/EHV: HV Generation Site Specific		0	-3.400	-0.323	-0.020	52.25			0.141
LDNO 132kV: Domestic Aggregated or CT with Residual		0, 1, 2	3.167	0.378	0.031	3.05			
LDNO 132kV: Domestic Aggregated (related MPAN)		2	3.167	0.378	0.031				

Tariff name	Unique billing identifier	PCs	Red/black unit charge p/kWh	Amber/yellow unit charge p/kWh	Green unit charge p/kWh	Fixed charge p/MPAN/day	Capacity charge p/kVA/day	Exceeded capacity charge p/kVA/day	Reactive power charge p/kVArh
LDNO 132kV: Non-Domestic Aggregated or CT No Residual		0, 3, 4, 5-8	3.066	0.366	0.030	3.01			
LDNO 132kV: Non-Domestic Aggregated or CT Band 1		0, 3, 4, 5-8	3.066	0.366	0.030	3.83			
LDNO 132kV: Non-Domestic Aggregated or CT Band 2		0, 3, 4, 5-8	3.066	0.366	0.030	6.09			
LDNO 132kV: Non-Domestic Aggregated or CT Band 3		0, 3, 4, 5-8	3.066	0.366	0.030	9.77			
LDNO 132kV: Non-Domestic Aggregated or CT Band 4		0, 3, 4, 5-8	3.066	0.366	0.030	20.75			
LDNO 132kV: Non-Domestic Aggregated (related MPAN)		4	3.066	0.366	0.030				
LDNO 132kV: LV Site Specific No Residual		0	2.077	0.232	0.018	3.54	1.96	1.96	0.061
LDNO 132kV: LV Site Specific Band 1		0	2.077	0.232	0.018	34.67	1.96	1.96	0.061
LDNO 132kV: LV Site Specific Band 2		0	2.077	0.232	0.018	56.28	1.96	1.96	0.061
LDNO 132kV: LV Site Specific Band 3		0	2.077	0.232	0.018	88.41	1.96	1.96	0.061
LDNO 132kV: LV Site Specific Band 4		0	2.077	0.232	0.018	174.12	1.96	1.96	0.061
LDNO 132kV: LV Sub Site Specific No Residual		0	2.062	0.196	0.012	4.17	2.85	2.85	0.058
LDNO 132kV: LV Sub Site Specific Band 1		0	2.062	0.196	0.012	51.12	2.85	2.85	0.058
LDNO 132kV: LV Sub Site Specific Band 2		0	2.062	0.196	0.012	83.71	2.85	2.85	0.058
LDNO 132kV: LV Sub Site Specific Band 3		0	2.062	0.196	0.012	132.17	2.85	2.85	0.058
LDNO 132kV: LV Sub Site Specific Band 4		0	2.062	0.196	0.012	261.44	2.85	2.85	0.058
LDNO 132kV: HV Site Specific No Residual		0	1.312	0.098	0.004	43.19	3.71	3.71	0.033
LDNO 132kV: HV Site Specific Band 1		0	1.312	0.098	0.004	399.94	3.71	3.71	0.033
LDNO 132kV: HV Site Specific Band 2		0	1.312	0.098	0.004	1085.52	3.71	3.71	0.033
LDNO 132kV: HV Site Specific Band 3		0	1.312	0.098	0.004	1973.61	3.71	3.71	0.033
LDNO 132kV: HV Site Specific Band 4		0	1.312	0.098	0.004	4948.92	3.71	3.71	0.033
LDNO 132kV: Unmetered Supplies		0, 1 or 8	9.840	0.735	0.411				
LDNO 132kV: LV Generation Aggregated		0	-3.010	-0.359	-0.030	0.00			
LDNO 132kV: LV Sub Generation Aggregated		0	-2.820	-0.323	-0.026	0.00			
LDNO 132kV: LV Generation Site Specific		0	-3.010	-0.359	-0.030	0.00			0.105
LDNO 132kV: LV Sub Generation Site Specific		0	-2.820	-0.323	-0.026	0.00			0.088
LDNO 132kV: HV Generation Site Specific		0	-2.536	-0.241	-0.015	38.97			0.105
LDNO 0000: Domestic Aggregated or CT with Residual		0, 1, 2	1.119	0.133	0.011	1.08			
LDNO 0000: Domestic Aggregated (related MPAN)		2	1.119	0.133	0.011				
LDNO 0000: Non-Domestic Aggregated or CT No Residual		0, 3, 4, 5-8	1.083	0.129	0.011	1.06			
LDNO 0000: Non-Domestic Aggregated or CT Band 1		0, 3, 4, 5-8	1.083	0.129	0.011	1.35			

Tariff name	Unique billing identifier	PCs	Red/black unit charge p/kWh	Amber/yellow unit charge p/kWh	Green unit charge p/kWh	Fixed charge p/MPAN/day	Capacity charge p/kVA/day	Exceeded capacity charge p/kVA/day	Reactive power charge p/kVArh
LDNO 0000: Non-Domestic Aggregated or CT Band 2		0, 3, 4, 5-8	1.083	0.129	0.011	2.15			
LDNO 0000: Non-Domestic Aggregated or CT Band 3		0, 3, 4, 5-8	1.083	0.129	0.011	3.45			
LDNO 0000: Non-Domestic Aggregated or CT Band 4		0, 3, 4, 5-8	1.083	0.129	0.011	7.33			
LDNO 0000: Non-Domestic Aggregated (related MPAN)		4	1.083	0.129	0.011				
LDNO 0000: LV Site Specific No Residual		0	0.734	0.082	0.006	1.25	0.69	0.69	0.022
LDNO 0000: LV Site Specific Band 1		0	0.734	0.082	0.006	12.25	0.69	0.69	0.022
LDNO 0000: LV Site Specific Band 2		0	0.734	0.082	0.006	19.88	0.69	0.69	0.022
LDNO 0000: LV Site Specific Band 3		0	0.734	0.082	0.006	31.23	0.69	0.69	0.022
LDNO 0000: LV Site Specific Band 4		0	0.734	0.082	0.006	61.50	0.69	0.69	0.022
LDNO 0000: LV Sub Site Specific No Residual		0	0.728	0.069	0.004	1.47	1.01	1.01	0.021
LDNO 0000: LV Sub Site Specific Band 1		0	0.728	0.069	0.004	18.06	1.01	1.01	0.021
LDNO 0000: LV Sub Site Specific Band 2		0	0.728	0.069	0.004	29.57	1.01	1.01	0.021
LDNO 0000: LV Sub Site Specific Band 3		0	0.728	0.069	0.004	46.68	1.01	1.01	0.021
LDNO 0000: LV Sub Site Specific Band 4		0	0.728	0.069	0.004	92.34	1.01	1.01	0.021
LDNO 0000: HV Site Specific No Residual		0	0.463	0.035	0.001	15.26	1.31	1.31	0.011
LDNO 0000: HV Site Specific Band 1		0	0.463	0.035	0.001	141.26	1.31	1.31	0.011
LDNO 0000: HV Site Specific Band 2		0	0.463	0.035	0.001	383.42	1.31	1.31	0.011
LDNO 0000: HV Site Specific Band 3		0	0.463	0.035	0.001	697.10	1.31	1.31	0.011
LDNO 0000: HV Site Specific Band 4		0	0.463	0.035	0.001	1748.01	1.31	1.31	0.011
LDNO 0000: Unmetered Supplies		0, 1 or 8	3.475	0.260	0.145				
LDNO 0000: LV Generation Aggregated		0	-1.063	-0.127	-0.010	0.00			
LDNO 0000: LV Sub Generation Aggregated		0	-0.996	-0.114	-0.009	0.00			
LDNO 0000: LV Generation Site Specific		0	-1.063	-0.127	-0.010	0.00			0.037
LDNO 0000: LV Sub Generation Site Specific		0	-0.996	-0.114	-0.009	0.00			0.031
LDNO 0000: HV Generation Site Specific		0	-0.896	-0.085	-0.005	13.77			0.037

## Annex 4 - Charges applied to LDNOs with HV/LV end users in “London Power Networks Area (GSP Group \_C)”

### Southern Electric Power Distribution plc - Effective from 1st April 2027 - Final LDNO tariffs in UKPN LPN Area (GSP Group \_C)

Time Bands for LV and HV Properties			
Time periods	Red Time Band	Amber Time Band	Green Time Band
Monday to Friday (Including Bank Holidays) All Year	11:00 - 14:00 16:00 - 19:00	07:00 - 11:00 14:00 - 16:00 19:00 - 23:00	00:00 - 07:00 23:00 - 24:00
Saturday and Sunday All Year			00:00 - 24:00
Notes	All times are in UK Clock time		

Time Bands for Unmetered Properties			
	Black Time Band	Yellow Time Band	Green Time Band
Monday to Friday (Including Bank Holidays) June to August Inclusive	11:00 - 14:00	07:00 - 11:00 14:00 - 23:00	00:00 - 07:00 23:00 - 24:00
Monday to Friday (Including Bank Holidays) November to February Inclusive	16:00 - 19:00	07:00 - 16:00 19:00 - 23:00	00:00 - 07:00 23:00 - 24:00
Monday to Friday (Including Bank Holidays) March, April, May and September, October		07:00 - 23:00	00:00 - 07:00 23:00 - 24:00
Saturday and Sunday All year			00:00 - 24:00
Notes	All times are in UK Clock time		

Tariff name	Unique billing identifier	PCs	Red/black unit charge p/kWh	Amber/yellow unit charge p/kWh	Green unit charge p/kWh	Fixed charge p/MPAN/day	Capacity charge p/kVA/day	Exceeded capacity charge p/kVA/day	Reactive power charge p/kVArh
LDNO LV: Domestic Aggregated or CT with Residual		0, 1, 2	8.454	0.861	0.000	0.00			
LDNO LV: Domestic Aggregated (related MPAN)		2	8.604	1.012	0.075				
LDNO LV: Non-Domestic Aggregated or CT No Residual		0, 3, 4, 5-8	6.661	0.784	0.058	4.10			
LDNO LV: Non-Domestic Aggregated or CT Band 1		0, 3, 4, 5-8	6.578	0.700	0.000	0.00			
LDNO LV: Non-Domestic Aggregated or CT Band 2		0, 3, 4, 5-8	5.991	0.114	0.000	0.00			
LDNO LV: Non-Domestic Aggregated or CT Band 3		0, 3, 4, 5-8	5.776	0.000	0.000	0.00			
LDNO LV: Non-Domestic Aggregated or CT Band 4		0, 3, 4, 5-8	5.498	0.000	0.000	0.00			
LDNO LV: Non-Domestic Aggregated (related MPAN)		4	6.661	0.784	0.058				
LDNO LV: LV Site Specific No Residual		0	5.295	0.639	0.043	10.05	5.73	5.73	0.407
LDNO LV: LV Site Specific Band 1		0	3.387	0.223	0.021	1.59	5.73	5.73	0.407

Tariff name	Unique billing identifier	PCs	Red/black unit charge p/kWh	Amber/yellow unit charge p/kWh	Green unit charge p/kWh	Fixed charge p/MPAN/day	Capacity charge p/kVA/day	Exceeded capacity charge p/kVA/day	Reactive power charge p/kVArh
LDNO LV: LV Site Specific Band 2		0	3.342	0.223	0.021	1.59	5.73	5.73	0.407
LDNO LV: LV Site Specific Band 3		0	3.301	0.223	0.021	1.59	5.73	5.73	0.407
LDNO LV: LV Site Specific Band 4		0	3.252	0.223	0.021	1.59	5.73	5.73	0.407
LDNO LV: Unmetered Supplies		0, 1 or 8	28.398	2.319	0.326				
LDNO LV: LV Generation Aggregated		0, 8	-7.828	-0.921	-0.068	0.00			
LDNO LV: LV Generation Site Specific		0	-7.828	-0.921	-0.068	0.00			0.550
LDNO HV: Domestic Aggregated or CT with Residual		0, 1, 2	6.533	0.666	0.000	0.00			
LDNO HV: Domestic Aggregated (Related MPAN)		2	6.650	0.782	0.058				
LDNO HV: Non-Domestic Aggregated or CT No Residual		0, 3, 4, 5-8	5.148	0.606	0.045	3.17			
LDNO HV: Non-Domestic Aggregated or CT Band 1		0, 3, 4, 5-8	5.084	0.541	0.000	0.00			
LDNO HV: Non-Domestic Aggregated or CT Band 2		0, 3, 4, 5-8	4.630	0.088	0.000	0.00			
LDNO HV: Non-Domestic Aggregated or CT Band 3		0, 3, 4, 5-8	4.464	0.000	0.000	0.00			
LDNO HV: Non-Domestic Aggregated or CT Band 4		0, 3, 4, 5-8	4.249	0.000	0.000	0.00			
LDNO HV: Non-Domestic Aggregated (related MPAN)		4	5.148	0.606	0.045				
LDNO HV: LV Site Specific No Residual		0	4.092	0.494	0.033	7.77	4.43	4.43	0.315
LDNO HV: LV Site Specific Band 1		0	2.617	0.173	0.016	1.23	4.43	4.43	0.315
LDNO HV: LV Site Specific Band 2		0	2.583	0.173	0.016	1.23	4.43	4.43	0.315
LDNO HV: LV Site Specific Band 3		0	2.551	0.173	0.016	1.23	4.43	4.43	0.315
LDNO HV: LV Site Specific Band 4		0	2.513	0.173	0.016	1.23	4.43	4.43	0.315
LDNO HV: LV Sub Site Specific No Residual		0	3.668	0.469	0.025	9.55	8.12	8.12	0.272
LDNO HV: LV Sub Site Specific Band 1		0	1.515	0.000	0.000	0.00	8.12	8.12	0.272
LDNO HV: LV Sub Site Specific Band 2		0	1.465	0.000	0.000	0.00	8.12	8.12	0.272
LDNO HV: LV Sub Site Specific Band 3		0	1.419	0.000	0.000	0.00	8.12	8.12	0.272
LDNO HV: LV Sub Site Specific Band 4		0	1.363	0.000	0.000	0.00	8.12	8.12	0.272
LDNO HV: HV Site Specific No Residual		0	3.031	0.387	0.022	112.49	9.25	9.25	0.236
LDNO HV: HV Site Specific Band 1		0	0.365	0.000	0.000	0.00	9.25	9.25	0.236
LDNO HV: HV Site Specific Band 2		0	0.194	0.000	0.000	0.00	9.25	9.25	0.236
LDNO HV: HV Site Specific Band 3		0	0.265	0.000	0.000	0.00	9.25	9.25	0.236
LDNO HV: HV Site Specific Band 4		0	0.209	0.000	0.000	0.00	9.25	9.25	0.236
LDNO HV: Unmetered Supplies		0, 1 or 8	21.946	1.793	0.252				
LDNO HV: LV Generation Aggregated		0, 8	-7.828	-0.921	-0.068	0.00			
LDNO HV: LV Sub Generation Aggregated		0	-6.433	-0.769	-0.054	0.00			
LDNO HV: LV Generation Site Specific		0	-7.828	-0.921	-0.068	0.00			0.550
LDNO HV: LV Sub Generation Site Specific		0	-6.433	-0.769	-0.054	0.00			0.433
LDNO HV: HV Generation Site Specific		0	-4.179	-0.534	-0.029	0.00			0.382

Tariff name	Unique billing identifier	PCs	Red/black unit charge p/kWh	Amber/yellow unit charge p/kWh	Green unit charge p/kWh	Fixed charge p/MPAN/day	Capacity charge p/kVA/day	Exceeded capacity charge p/kVA/day	Reactive power charge p/kVArh
LDNO HVplus: Domestic Aggregated or CT with Residual		0, 1, 2	5.826	0.594	0.000	0.00			
LDNO HVplus: Domestic Aggregated (related MPAN)		2	5.930	0.698	0.051				
LDNO HVplus: Non-Domestic Aggregated or CT No Residual		0, 3, 4, 5-8	4.591	0.540	0.040	2.82			
LDNO HVplus: Non-Domestic Aggregated or CT Band 1		0, 3, 4, 5-8	4.533	0.483	0.000	0.00			
LDNO HVplus: Non-Domestic Aggregated or CT Band 2		0, 3, 4, 5-8	4.129	0.078	0.000	0.00			
LDNO HVplus: Non-Domestic Aggregated or CT Band 3		0, 3, 4, 5-8	3.981	0.000	0.000	0.00			
LDNO HVplus: Non-Domestic Aggregated or CT Band 4		0, 3, 4, 5-8	3.789	0.000	0.000	0.00			
LDNO HVplus: Non-Domestic Aggregated (related MPAN)		4	4.591	0.540	0.040				
LDNO HVplus: LV Site Specific No Residual		0	3.649	0.440	0.030	6.93	3.95	3.95	0.281
LDNO HVplus: LV Site Specific Band 1		0	2.334	0.154	0.014	1.10	3.95	3.95	0.281
LDNO HVplus: LV Site Specific Band 2		0	2.303	0.154	0.014	1.10	3.95	3.95	0.281
LDNO HVplus: LV Site Specific Band 3		0	2.275	0.154	0.014	1.10	3.95	3.95	0.281
LDNO HVplus: LV Site Specific Band 4		0	2.241	0.154	0.014	1.10	3.95	3.95	0.281
LDNO HVplus: LV Sub Site Specific No Residual		0	3.244	0.414	0.023	8.44	7.18	7.18	0.241
LDNO HVplus: LV Sub Site Specific Band 1		0	1.340	0.000	0.000	0.00	7.18	7.18	0.241
LDNO HVplus: LV Sub Site Specific Band 2		0	1.295	0.000	0.000	0.00	7.18	7.18	0.241
LDNO HVplus: LV Sub Site Specific Band 3		0	1.255	0.000	0.000	0.00	7.18	7.18	0.241
LDNO HVplus: LV Sub Site Specific Band 4		0	1.205	0.000	0.000	0.00	7.18	7.18	0.241
LDNO HVplus: HV Site Specific No Residual		0	2.668	0.341	0.020	99.00	8.14	8.14	0.208
LDNO HVplus: HV Site Specific Band 1		0	0.322	0.000	0.000	0.00	8.14	8.14	0.208
LDNO HVplus: HV Site Specific Band 2		0	0.171	0.000	0.000	0.00	8.14	8.14	0.208
LDNO HVplus: HV Site Specific Band 3		0	0.233	0.000	0.000	0.00	8.14	8.14	0.208
LDNO HVplus: HV Site Specific Band 4		0	0.184	0.000	0.000	0.00	8.14	8.14	0.208
LDNO HVplus: Unmetered Supplies		0, 1 or 8	19.571	1.599	0.225				
LDNO HVplus: LV Generation Aggregated		0, 8	-5.414	-0.637	-0.047	0.00			
LDNO HVplus: LV Sub Generation Aggregated		0	-4.921	-0.588	-0.041	0.00			
LDNO HVplus: LV Generation Site Specific		0	-5.414	-0.637	-0.047	0.00			0.380
LDNO HVplus: LV Sub Generation Site Specific		0	-4.921	-0.588	-0.041	0.00			0.331
LDNO HVplus: HV Generation Site Specific		0	-4.179	-0.534	-0.029	9.08			0.382

Tariff name	Unique billing identifier	PCs	Red/black unit charge p/kWh	Amber/yellow unit charge p/kWh	Green unit charge p/kWh	Fixed charge p/MPAN/day	Capacity charge p/kVA/day	Exceeded capacity charge p/kVA/day	Reactive power charge p/kVArh
LDNO EHV: Domestic Aggregated or CT with Residual		0, 1, 2	4.473	0.456	0.000	0.00			
LDNO EHV: Domestic Aggregated (related MPAN)		2	4.552	0.535	0.040				
LDNO EHV: Non-Domestic Aggregated or CT No Residual		0, 3, 4, 5-8	3.524	0.415	0.031	2.17			
LDNO EHV: Non-Domestic Aggregated or CT Band 1		0, 3, 4, 5-8	3.480	0.371	0.000	0.00			
LDNO EHV: Non-Domestic Aggregated or CT Band 2		0, 3, 4, 5-8	3.170	0.060	0.000	0.00			
LDNO EHV: Non-Domestic Aggregated or CT Band 3		0, 3, 4, 5-8	3.056	0.000	0.000	0.00			
LDNO EHV: Non-Domestic Aggregated or CT Band 4		0, 3, 4, 5-8	2.909	0.000	0.000	0.00			
LDNO EHV: Non-Domestic Aggregated (related MPAN)		4	3.524	0.415	0.031				
LDNO EHV: LV Site Specific No Residual		0	2.801	0.338	0.023	5.32	3.03	3.03	0.215
LDNO EHV: LV Site Specific Band 1		0	1.792	0.118	0.011	0.84	3.03	3.03	0.215
LDNO EHV: LV Site Specific Band 2		0	1.768	0.118	0.011	0.84	3.03	3.03	0.215
LDNO EHV: LV Site Specific Band 3		0	1.747	0.118	0.011	0.84	3.03	3.03	0.215
LDNO EHV: LV Site Specific Band 4		0	1.720	0.118	0.011	0.84	3.03	3.03	0.215
LDNO EHV: LV Sub Site Specific No Residual		0	2.490	0.318	0.017	6.48	5.51	5.51	0.185
LDNO EHV: LV Sub Site Specific Band 1		0	1.029	0.000	0.000	0.00	5.51	5.51	0.185
LDNO EHV: LV Sub Site Specific Band 2		0	0.994	0.000	0.000	0.00	5.51	5.51	0.185
LDNO EHV: LV Sub Site Specific Band 3		0	0.964	0.000	0.000	0.00	5.51	5.51	0.185
LDNO EHV: LV Sub Site Specific Band 4		0	0.925	0.000	0.000	0.00	5.51	5.51	0.185
LDNO EHV: HV Site Specific No Residual		0	2.048	0.262	0.015	76.00	6.25	6.25	0.159
LDNO EHV: HV Site Specific Band 1		0	0.247	0.000	0.000	0.00	6.25	6.25	0.159
LDNO EHV: HV Site Specific Band 2		0	0.131	0.000	0.000	0.00	6.25	6.25	0.159
LDNO EHV: HV Site Specific Band 3		0	0.179	0.000	0.000	0.00	6.25	6.25	0.159
LDNO EHV: HV Site Specific Band 4		0	0.141	0.000	0.000	0.00	6.25	6.25	0.159
LDNO EHV: Unmetered Supplies		0, 1 or 8	15.025	1.227	0.173				
LDNO EHV: LV Generation Aggregated		0, 8	-4.156	-0.489	-0.036	0.00			
LDNO EHV: LV Sub Generation Aggregated		0	-3.778	-0.451	-0.032	0.00			
LDNO EHV: LV Generation Site Specific		0	-4.156	-0.489	-0.036	0.00			0.292
LDNO EHV: LV Sub Generation Site Specific		0	-3.778	-0.451	-0.032	0.00			0.254
LDNO EHV: HV Generation Site Specific		0	-3.208	-0.410	-0.022	6.97			0.293
LDNO 132kV/EHV: Domestic Aggregated or CT with Residual		0, 1, 2	2.775	0.283	0.000	0.00			
LDNO 132kV/EHV: Domestic Aggregated (related MPAN)		2	2.825	0.332	0.025				

Tariff name	Unique billing identifier	PCs	Red/black unit charge p/kWh	Amber/yellow unit charge p/kWh	Green unit charge p/kWh	Fixed charge p/MPAN/day	Capacity charge p/kVA/day	Exceeded capacity charge p/kVA/day	Reactive power charge p/kVArh
LDNO 132kV/EHV: Non-Domestic Aggregated or CT No Residual		0, 3, 4, 5-8	2.187	0.257	0.019	1.34			
LDNO 132kV/EHV: Non-Domestic Aggregated or CT Band 1		0, 3, 4, 5-8	2.159	0.230	0.000	0.00			
LDNO 132kV/EHV: Non-Domestic Aggregated or CT Band 2		0, 3, 4, 5-8	1.967	0.037	0.000	0.00			
LDNO 132kV/EHV: Non-Domestic Aggregated or CT Band 3		0, 3, 4, 5-8	1.896	0.000	0.000	0.00			
LDNO 132kV/EHV: Non-Domestic Aggregated or CT Band 4		0, 3, 4, 5-8	1.805	0.000	0.000	0.00			
LDNO 132kV/EHV: Non-Domestic Aggregated (related MPAN)		4	2.187	0.257	0.019				
LDNO 132kV/EHV: LV Site Specific No Residual		0	1.738	0.210	0.014	3.30	1.88	1.88	0.134
LDNO 132kV/EHV: LV Site Specific Band 1		0	1.112	0.073	0.007	0.52	1.88	1.88	0.134
LDNO 132kV/EHV: LV Site Specific Band 2		0	1.097	0.073	0.007	0.52	1.88	1.88	0.134
LDNO 132kV/EHV: LV Site Specific Band 3		0	1.084	0.073	0.007	0.52	1.88	1.88	0.134
LDNO 132kV/EHV: LV Site Specific Band 4		0	1.068	0.073	0.007	0.52	1.88	1.88	0.134
LDNO 132kV/EHV: LV Sub Site Specific No Residual		0	1.545	0.197	0.011	4.02	3.42	3.42	0.115
LDNO 132kV/EHV: LV Sub Site Specific Band 1		0	0.638	0.000	0.000	0.00	3.42	3.42	0.115
LDNO 132kV/EHV: LV Sub Site Specific Band 2		0	0.617	0.000	0.000	0.00	3.42	3.42	0.115
LDNO 132kV/EHV: LV Sub Site Specific Band 3		0	0.598	0.000	0.000	0.00	3.42	3.42	0.115
LDNO 132kV/EHV: LV Sub Site Specific Band 4		0	0.574	0.000	0.000	0.00	3.42	3.42	0.115
LDNO 132kV/EHV: HV Site Specific No Residual		0	1.271	0.162	0.009	47.16	3.88	3.88	0.099
LDNO 132kV/EHV: HV Site Specific Band 1		0	0.153	0.000	0.000	0.00	3.88	3.88	0.099
LDNO 132kV/EHV: HV Site Specific Band 2		0	0.081	0.000	0.000	0.00	3.88	3.88	0.099
LDNO 132kV/EHV: HV Site Specific Band 3		0	0.111	0.000	0.000	0.00	3.88	3.88	0.099
LDNO 132kV/EHV: HV Site Specific Band 4		0	0.087	0.000	0.000	0.00	3.88	3.88	0.099
LDNO 132kV/EHV: Unmetered Supplies		0, 1 or 8	9.323	0.761	0.107				
LDNO 132kV/EHV: LV Generation Aggregated		0, 8	-2.579	-0.303	-0.022	0.00			
LDNO 132kV/EHV: LV Sub Generation Aggregated		0	-2.344	-0.280	-0.020	0.00			
LDNO 132kV/EHV: LV Generation Site Specific		0	-2.579	-0.303	-0.022	0.00			0.181
LDNO 132kV/EHV: LV Sub Generation Site Specific		0	-2.344	-0.280	-0.020	0.00			0.158
LDNO 132kV/EHV: HV Generation Site Specific		0	-1.991	-0.254	-0.014	4.33			0.182
LDNO 132kV: Domestic Aggregated or CT with Residual		0, 1, 2	1.955	0.199	0.000	0.00			
LDNO 132kV: Domestic Aggregated (related MPAN)		2	1.990	0.234	0.017				

Tariff name	Unique billing identifier	PCs	Red/black unit charge p/kWh	Amber/yellow unit charge p/kWh	Green unit charge p/kWh	Fixed charge p/MPAN/day	Capacity charge p/kVA/day	Exceeded capacity charge p/kVA/day	Reactive power charge p/kVArh
LDNO 132kV: Non-Domestic Aggregated or CT No Residual		0, 3, 4, 5-8	1.540	0.181	0.013	0.95			
LDNO 132kV: Non-Domestic Aggregated or CT Band 1		0, 3, 4, 5-8	1.521	0.162	0.000	0.00			
LDNO 132kV: Non-Domestic Aggregated or CT Band 2		0, 3, 4, 5-8	1.386	0.026	0.000	0.00			
LDNO 132kV: Non-Domestic Aggregated or CT Band 3		0, 3, 4, 5-8	1.336	0.000	0.000	0.00			
LDNO 132kV: Non-Domestic Aggregated or CT Band 4		0, 3, 4, 5-8	1.271	0.000	0.000	0.00			
LDNO 132kV: Non-Domestic Aggregated (related MPAN)		4	1.540	0.181	0.013				
LDNO 132kV: LV Site Specific No Residual		0	1.224	0.148	0.010	2.33	1.32	1.32	0.094
LDNO 132kV: LV Site Specific Band 1		0	0.783	0.052	0.005	0.37	1.32	1.32	0.094
LDNO 132kV: LV Site Specific Band 2		0	0.773	0.052	0.005	0.37	1.32	1.32	0.094
LDNO 132kV: LV Site Specific Band 3		0	0.763	0.052	0.005	0.37	1.32	1.32	0.094
LDNO 132kV: LV Site Specific Band 4		0	0.752	0.052	0.005	0.37	1.32	1.32	0.094
LDNO 132kV: LV Sub Site Specific No Residual		0	1.088	0.139	0.008	2.83	2.41	2.41	0.081
LDNO 132kV: LV Sub Site Specific Band 1		0	0.450	0.000	0.000	0.00	2.41	2.41	0.081
LDNO 132kV: LV Sub Site Specific Band 2		0	0.435	0.000	0.000	0.00	2.41	2.41	0.081
LDNO 132kV: LV Sub Site Specific Band 3		0	0.421	0.000	0.000	0.00	2.41	2.41	0.081
LDNO 132kV: LV Sub Site Specific Band 4		0	0.404	0.000	0.000	0.00	2.41	2.41	0.081
LDNO 132kV: HV Site Specific No Residual		0	0.895	0.114	0.007	33.22	2.73	2.73	0.070
LDNO 132kV: HV Site Specific Band 1		0	0.108	0.000	0.000	0.00	2.73	2.73	0.070
LDNO 132kV: HV Site Specific Band 2		0	0.057	0.000	0.000	0.00	2.73	2.73	0.070
LDNO 132kV: HV Site Specific Band 3		0	0.078	0.000	0.000	0.00	2.73	2.73	0.070
LDNO 132kV: HV Site Specific Band 4		0	0.062	0.000	0.000	0.00	2.73	2.73	0.070
LDNO 132kV: Unmetered Supplies		0, 1 or 8	6.567	0.536	0.075				
LDNO 132kV: LV Generation Aggregated		0, 8	-1.816	-0.214	-0.016	0.00			
LDNO 132kV: LV Sub Generation Aggregated		0	-1.651	-0.197	-0.014	0.00			
LDNO 132kV: LV Generation Site Specific		0	-1.816	-0.214	-0.016	0.00			0.128
LDNO 132kV: LV Sub Generation Site Specific		0	-1.651	-0.197	-0.014	0.00			0.111
LDNO 132kV: HV Generation Site Specific		0	-1.402	-0.179	-0.010	3.05			0.128
LDNO 0000: Domestic Aggregated or CT with Residual		0, 1, 2	0.809	0.082	0.000	0.00			
LDNO 0000: Domestic Aggregated (related MPAN)		2	0.824	0.097	0.007				
LDNO 0000: Non-Domestic Aggregated or CT No Residual		0, 3, 4, 5-8	0.638	0.075	0.006	0.39			
LDNO 0000: Non-Domestic Aggregated or CT Band 1		0, 3, 4, 5-8	0.630	0.067	0.000	0.00			

Tariff name	Unique billing identifier	PCs	Red/black unit charge p/kWh	Amber/yellow unit charge p/kWh	Green unit charge p/kWh	Fixed charge p/MPAN/day	Capacity charge p/kVA/day	Exceeded capacity charge p/kVA/day	Reactive power charge p/kVArh
LDNO 0000: Non-Domestic Aggregated or CT Band 2		0, 3, 4, 5-8	0.574	0.011	0.000	0.00			
LDNO 0000: Non-Domestic Aggregated or CT Band 3		0, 3, 4, 5-8	0.553	0.000	0.000	0.00			
LDNO 0000: Non-Domestic Aggregated or CT Band 4		0, 3, 4, 5-8	0.526	0.000	0.000	0.00			
LDNO 0000: Non-Domestic Aggregated (related MPAN)		4	0.638	0.075	0.006				
LDNO 0000: LV Site Specific No Residual		0	0.507	0.061	0.004	0.96	0.55	0.55	0.039
LDNO 0000: LV Site Specific Band 1		0	0.324	0.021	0.002	0.15	0.55	0.55	0.039
LDNO 0000: LV Site Specific Band 2		0	0.320	0.021	0.002	0.15	0.55	0.55	0.039
LDNO 0000: LV Site Specific Band 3		0	0.316	0.021	0.002	0.15	0.55	0.55	0.039
LDNO 0000: LV Site Specific Band 4		0	0.311	0.021	0.002	0.15	0.55	0.55	0.039
LDNO 0000: LV Sub Site Specific No Residual		0	0.451	0.058	0.003	1.17	1.00	1.00	0.033
LDNO 0000: LV Sub Site Specific Band 1		0	0.186	0.000	0.000	0.00	1.00	1.00	0.033
LDNO 0000: LV Sub Site Specific Band 2		0	0.180	0.000	0.000	0.00	1.00	1.00	0.033
LDNO 0000: LV Sub Site Specific Band 3		0	0.174	0.000	0.000	0.00	1.00	1.00	0.033
LDNO 0000: LV Sub Site Specific Band 4		0	0.167	0.000	0.000	0.00	1.00	1.00	0.033
LDNO 0000: HV Site Specific No Residual		0	0.371	0.047	0.003	13.75	1.13	1.13	0.029
LDNO 0000: HV Site Specific Band 1		0	0.045	0.000	0.000	0.00	1.13	1.13	0.029
LDNO 0000: HV Site Specific Band 2		0	0.024	0.000	0.000	0.00	1.13	1.13	0.029
LDNO 0000: HV Site Specific Band 3		0	0.032	0.000	0.000	0.00	1.13	1.13	0.029
LDNO 0000: HV Site Specific Band 4		0	0.025	0.000	0.000	0.00	1.13	1.13	0.029
LDNO 0000: Unmetered Supplies		0, 1 or 8	2.719	0.222	0.031				
LDNO 0000: LV Generation Aggregated		0, 8	-0.752	-0.088	-0.007	0.00			
LDNO 0000: LV Sub Generation Aggregated		0	-0.684	-0.082	-0.006	0.00			
LDNO 0000: LV Generation Site Specific		0	-0.752	-0.088	-0.007	0.00			0.053
LDNO 0000: LV Sub Generation Site Specific		0	-0.684	-0.082	-0.006	0.00			0.046
LDNO 0000: HV Generation Site Specific		0	-0.581	-0.074	-0.004	1.26			0.053

## Annex 4 - Charges applied to LDNOs with HV/LV end users in “SP Manweb Area (GSP Group \_D)”

### Southern Electric Power Distribution plc - Effective from 1st April 2027 - Final LDNO tariffs in SP Manweb Area (GSP Group \_D)

Time Bands for LV and HV Properties			
Time periods	Red Time Band	Amber Time Band	Green Time Band
Monday to Friday (Including Bank Holidays) All Year	16.30 - 19.30	08.00 - 16.30 19.30 - 22.30	00.00 - 08.00 22.30 - 00.00
Saturday and Sunday All Year		16.00 - 20.00	00.00 - 16.00 20.00 - 00.00
Notes	All the above times are in UK Clock time		

Time Bands for Unmetered Properties			
	Black Time Band	Yellow Time Band	Green Time Band
Monday to Friday (Including Bank Holidays) June to August Inclusive		08.00 - 22.30	00.00 - 08.00 22.30 - 00.00
Monday to Friday (Including Bank Holidays) November to February Inclusive	16.30 - 19.30	08.00 - 16.30 19.30 - 22.30	00.00 - 08.00 22.30 - 00.00
Monday to Friday (Including Bank Holidays) March to May, & September to October, Inclusive		08.00 - 22.30	00.00 - 08.00 22.30 - 00.00
Saturday and Sunday All Year		16.00 - 20.00	00:00-16:00 20:00-00:00
Notes	All the above times are in UK Clock time		

Tariff name	Unique billing identifier	PCs	Red/black unit charge p/kWh	Amber/yellow unit charge p/kWh	Green unit charge p/kWh	Fixed charge p/MPAN/day	Capacity charge p/kVA/day	Exceeded capacity charge p/kVA/day	Reactive power charge p/kVArh
LDNO LV: Domestic Aggregated or CT with Residual			9.415	2.036	0.274	14.76			
LDNO LV: Domestic Aggregated (related MPAN)			9.415	2.036	0.274				
LDNO LV: Non-Domestic Aggregated or CT No Residual			9.804	2.120	0.285	4.18			
LDNO LV: Non-Domestic Aggregated or CT Band 1			9.804	2.120	0.285	18.35			
LDNO LV: Non-Domestic Aggregated or CT Band 2			9.804	2.120	0.285	32.24			
LDNO LV: Non-Domestic Aggregated or CT Band 3			9.804	2.120	0.285	63.35			
LDNO LV: Non-Domestic Aggregated or CT Band 4			9.804	2.120	0.285	175.54			
LDNO LV: Non-Domestic Aggregated (related MPAN)			9.804	2.120	0.285				
LDNO LV: LV Site Specific No Residual			7.107	1.399	0.181	13.58	4.08	4.08	0.382
LDNO LV: LV Site Specific Band 1			7.107	1.399	0.181	344.52	4.08	4.08	0.382

Tariff name	Unique billing identifier	PCs	Red/black unit charge p/kWh	Amber/yellow unit charge p/kWh	Green unit charge p/kWh	Fixed charge p/MPAN/day	Capacity charge p/kVA/day	Exceeded capacity charge p/kVA/day	Reactive power charge p/kVArh
LDNO LV: LV Site Specific Band 2			7.107	1.399	0.181	638.58	4.08	4.08	0.382
LDNO LV: LV Site Specific Band 3			7.107	1.399	0.181	1004.49	4.08	4.08	0.382
LDNO LV: LV Site Specific Band 4			7.107	1.399	0.181	2295.76	4.08	4.08	0.382
LDNO LV: Unmetered Supplies			21.071	3.286	1.781				
LDNO LV: LV Generation Aggregated			-11.140	-2.409	-0.324	0.00			
LDNO LV: LV Generation Site Specific			-11.140	-2.409	-0.324	0.00			0.610
LDNO HV: Domestic Aggregated or CT with Residual			6.827	1.477	0.198	10.71			
LDNO HV: Domestic Aggregated (Related MPAN)			6.827	1.477	0.198				
LDNO HV: Non-Domestic Aggregated or CT No Residual			7.110	1.538	0.207	3.03			
LDNO HV: Non-Domestic Aggregated or CT Band 1			7.110	1.538	0.207	13.31			
LDNO HV: Non-Domestic Aggregated or CT Band 2			7.110	1.538	0.207	23.38			
LDNO HV: Non-Domestic Aggregated or CT Band 3			7.110	1.538	0.207	45.94			
LDNO HV: Non-Domestic Aggregated or CT Band 4			7.110	1.538	0.207	127.30			
LDNO HV: Non-Domestic Aggregated (related MPAN)			7.110	1.538	0.207				
LDNO HV: LV Site Specific No Residual			5.154	1.015	0.131	9.85	2.96	2.96	0.277
LDNO HV: LV Site Specific Band 1			5.154	1.015	0.131	249.84	2.96	2.96	0.277
LDNO HV: LV Site Specific Band 2			5.154	1.015	0.131	463.09	2.96	2.96	0.277
LDNO HV: LV Site Specific Band 3			5.154	1.015	0.131	728.45	2.96	2.96	0.277
LDNO HV: LV Site Specific Band 4			5.154	1.015	0.131	1664.87	2.96	2.96	0.277
LDNO HV: LV Sub Site Specific No Residual			6.354	1.011	0.117	5.91	7.81	7.81	0.265
LDNO HV: LV Sub Site Specific Band 1			6.354	1.011	0.117	414.07	7.81	7.81	0.265
LDNO HV: LV Sub Site Specific Band 2			6.354	1.011	0.117	776.73	7.81	7.81	0.265
LDNO HV: LV Sub Site Specific Band 3			6.354	1.011	0.117	1228.02	7.81	7.81	0.265
LDNO HV: LV Sub Site Specific Band 4			6.354	1.011	0.117	2820.55	7.81	7.81	0.265
LDNO HV: HV Site Specific No Residual			5.627	0.822	0.085	100.71	8.17	8.17	0.214
LDNO HV: HV Site Specific Band 1			5.627	0.822	0.085	2592.66	8.17	8.17	0.214
LDNO HV: HV Site Specific Band 2			5.627	0.822	0.085	7677.36	8.17	8.17	0.214
LDNO HV: HV Site Specific Band 3			5.627	0.822	0.085	16825.95	8.17	8.17	0.214
LDNO HV: HV Site Specific Band 4			5.627	0.822	0.085	32226.16	8.17	8.17	0.214
LDNO HV: Unmetered Supplies			15.281	2.383	1.291				
LDNO HV: LV Generation Aggregated			-11.140	-2.409	-0.324	0.00			
LDNO HV: LV Sub Generation Aggregated			-9.507	-1.940	-0.255	0.00			
LDNO HV: LV Generation Site Specific			-11.140	-2.409	-0.324	0.00			0.610
LDNO HV: LV Sub Generation Site Specific			-9.507	-1.940	-0.255	0.00			0.527
LDNO HV: HV Generation Site Specific			-7.061	-1.124	-0.130	0.00			0.446

Tariff name	Unique billing identifier	PCs	Red/black unit charge p/kWh	Amber/yellow unit charge p/kWh	Green unit charge p/kWh	Fixed charge p/MPAN/day	Capacity charge p/kVA/day	Exceeded capacity charge p/kVA/day	Reactive power charge p/kVArh
LDNO HVplus: Domestic Aggregated or CT with Residual			4.789	1.036	0.139	7.51			
LDNO HVplus: Domestic Aggregated (related MPAN)			4.789	1.036	0.139				
LDNO HVplus: Non-Domestic Aggregated or CT No Residual			4.987	1.079	0.145	2.12			
LDNO HVplus: Non-Domestic Aggregated or CT Band 1			4.987	1.079	0.145	9.34			
LDNO HVplus: Non-Domestic Aggregated or CT Band 2			4.987	1.079	0.145	16.40			
LDNO HVplus: Non-Domestic Aggregated or CT Band 3			4.987	1.079	0.145	32.22			
LDNO HVplus: Non-Domestic Aggregated or CT Band 4			4.987	1.079	0.145	89.30			
LDNO HVplus: Non-Domestic Aggregated (related MPAN)			4.987	1.079	0.145				
LDNO HVplus: LV Site Specific No Residual			3.615	0.712	0.092	6.91	2.07	2.07	0.194
LDNO HVplus: LV Site Specific Band 1			3.615	0.712	0.092	175.25	2.07	2.07	0.194
LDNO HVplus: LV Site Specific Band 2			3.615	0.712	0.092	324.83	2.07	2.07	0.194
LDNO HVplus: LV Site Specific Band 3			3.615	0.712	0.092	510.97	2.07	2.07	0.194
LDNO HVplus: LV Site Specific Band 4			3.615	0.712	0.092	1167.81	2.07	2.07	0.194
LDNO HVplus: LV Sub Site Specific No Residual			4.308	0.686	0.079	4.01	5.29	5.29	0.179
LDNO HVplus: LV Sub Site Specific Band 1			4.308	0.686	0.079	280.75	5.29	5.29	0.179
LDNO HVplus: LV Sub Site Specific Band 2			4.308	0.686	0.079	526.65	5.29	5.29	0.179
LDNO HVplus: LV Sub Site Specific Band 3			4.308	0.686	0.079	832.64	5.29	5.29	0.179
LDNO HVplus: LV Sub Site Specific Band 4			4.308	0.686	0.079	1912.44	5.29	5.29	0.179
LDNO HVplus: HV Site Specific No Residual			3.774	0.551	0.057	67.55	5.48	5.48	0.143
LDNO HVplus: HV Site Specific Band 1			3.774	0.551	0.057	1738.96	5.48	5.48	0.143
LDNO HVplus: HV Site Specific Band 2			3.774	0.551	0.057	5149.41	5.48	5.48	0.143
LDNO HVplus: HV Site Specific Band 3			3.774	0.551	0.057	11285.62	5.48	5.48	0.143
LDNO HVplus: HV Site Specific Band 4			3.774	0.551	0.057	21614.95	5.48	5.48	0.143
LDNO HVplus: Unmetered Supplies			10.719	1.671	0.906				
LDNO HVplus: LV Generation Aggregated			-5.489	-1.187	-0.160	0.00			
LDNO HVplus: LV Sub Generation Aggregated			-5.216	-1.065	-0.140	0.00			
LDNO HVplus: LV Generation Site Specific			-5.489	-1.187	-0.160	0.00			0.301
LDNO HVplus: LV Sub Generation Site Specific			-5.216	-1.065	-0.140	0.00			0.289
LDNO HVplus: HV Generation Site Specific			-7.061	-1.124	-0.130	89.91			0.446
LDNO EHV: Domestic Aggregated or CT with Residual			3.418	0.739	0.099	5.36			
LDNO EHV: Domestic Aggregated (related MPAN)			3.418	0.739	0.099				

Tariff name	Unique billing identifier	PCs	Red/black unit charge p/kWh	Amber/yellow unit charge p/kWh	Green unit charge p/kWh	Fixed charge p/MPAN/day	Capacity charge p/kVA/day	Exceeded capacity charge p/kVA/day	Reactive power charge p/kVArh
LDNO EHV: Non-Domestic Aggregated or CT No Residual			3.559	0.770	0.103	1.52			
LDNO EHV: Non-Domestic Aggregated or CT Band 1			3.559	0.770	0.103	6.66			
LDNO EHV: Non-Domestic Aggregated or CT Band 2			3.559	0.770	0.103	11.70			
LDNO EHV: Non-Domestic Aggregated or CT Band 3			3.559	0.770	0.103	23.00			
LDNO EHV: Non-Domestic Aggregated or CT Band 4			3.559	0.770	0.103	63.72			
LDNO EHV: Non-Domestic Aggregated (related MPAN)			3.559	0.770	0.103				
LDNO EHV: LV Site Specific No Residual			2.580	0.508	0.066	4.93	1.48	1.48	0.138
LDNO EHV: LV Site Specific Band 1			2.580	0.508	0.066	125.07	1.48	1.48	0.138
LDNO EHV: LV Site Specific Band 2			2.580	0.508	0.066	231.81	1.48	1.48	0.138
LDNO EHV: LV Site Specific Band 3			2.580	0.508	0.066	364.64	1.48	1.48	0.138
LDNO EHV: LV Site Specific Band 4			2.580	0.508	0.066	833.39	1.48	1.48	0.138
LDNO EHV: LV Sub Site Specific No Residual			3.074	0.489	0.057	2.86	3.78	3.78	0.128
LDNO EHV: LV Sub Site Specific Band 1			3.074	0.489	0.057	200.35	3.78	3.78	0.128
LDNO EHV: LV Sub Site Specific Band 2			3.074	0.489	0.057	375.84	3.78	3.78	0.128
LDNO EHV: LV Sub Site Specific Band 3			3.074	0.489	0.057	594.20	3.78	3.78	0.128
LDNO EHV: LV Sub Site Specific Band 4			3.074	0.489	0.057	1364.78	3.78	3.78	0.128
LDNO EHV: HV Site Specific No Residual			2.693	0.393	0.041	48.21	3.91	3.91	0.102
LDNO EHV: HV Site Specific Band 1			2.693	0.393	0.041	1240.98	3.91	3.91	0.102
LDNO EHV: HV Site Specific Band 2			2.693	0.393	0.041	3674.78	3.91	3.91	0.102
LDNO EHV: HV Site Specific Band 3			2.693	0.393	0.041	8053.77	3.91	3.91	0.102
LDNO EHV: HV Site Specific Band 4			2.693	0.393	0.041	15425.11	3.91	3.91	0.102
LDNO EHV: Unmetered Supplies			7.649	1.193	0.646				
LDNO EHV: LV Generation Aggregated			-3.917	-0.847	-0.114	0.00			
LDNO EHV: LV Sub Generation Aggregated			-3.722	-0.760	-0.100	0.00			
LDNO EHV: LV Generation Site Specific			-3.917	-0.847	-0.114	0.00			0.215
LDNO EHV: LV Sub Generation Site Specific			-3.722	-0.760	-0.100	0.00			0.206
LDNO EHV: HV Generation Site Specific			-5.039	-0.802	-0.093	64.16			0.318
LDNO 132kV/EHV: Domestic Aggregated or CT with Residual			2.547	0.551	0.074	3.99			
LDNO 132kV/EHV: Domestic Aggregated (related MPAN)			2.547	0.551	0.074				
LDNO 132kV/EHV: Non-Domestic Aggregated or CT No Residual			2.652	0.574	0.077	1.13			

Tariff name	Unique billing identifier	PCs	Red/black unit charge p/kWh	Amber/yellow unit charge p/kWh	Green unit charge p/kWh	Fixed charge p/MPAN/day	Capacity charge p/kVA/day	Exceeded capacity charge p/kVA/day	Reactive power charge p/kVArh
LDNO 132kV/EHV: Non-Domestic Aggregated or CT Band 1			2.652	0.574	0.077	4.97			
LDNO 132kV/EHV: Non-Domestic Aggregated or CT Band 2			2.652	0.574	0.077	8.72			
LDNO 132kV/EHV: Non-Domestic Aggregated or CT Band 3			2.652	0.574	0.077	17.14			
LDNO 132kV/EHV: Non-Domestic Aggregated or CT Band 4			2.652	0.574	0.077	47.49			
LDNO 132kV/EHV: Non-Domestic Aggregated (related MPAN)			2.652	0.574	0.077				
LDNO 132kV/EHV: LV Site Specific No Residual			1.923	0.379	0.049	3.67	1.10	1.10	0.103
LDNO 132kV/EHV: LV Site Specific Band 1			1.923	0.379	0.049	93.21	1.10	1.10	0.103
LDNO 132kV/EHV: LV Site Specific Band 2			1.923	0.379	0.049	172.76	1.10	1.10	0.103
LDNO 132kV/EHV: LV Site Specific Band 3			1.923	0.379	0.049	271.75	1.10	1.10	0.103
LDNO 132kV/EHV: LV Site Specific Band 4			1.923	0.379	0.049	621.09	1.10	1.10	0.103
LDNO 132kV/EHV: LV Sub Site Specific No Residual			2.291	0.365	0.042	2.13	2.81	2.81	0.095
LDNO 132kV/EHV: LV Sub Site Specific Band 1			2.291	0.365	0.042	149.32	2.81	2.81	0.095
LDNO 132kV/EHV: LV Sub Site Specific Band 2			2.291	0.365	0.042	280.10	2.81	2.81	0.095
LDNO 132kV/EHV: LV Sub Site Specific Band 3			2.291	0.365	0.042	442.84	2.81	2.81	0.095
LDNO 132kV/EHV: LV Sub Site Specific Band 4			2.291	0.365	0.042	1017.12	2.81	2.81	0.095
LDNO 132kV/EHV: HV Site Specific No Residual			2.007	0.293	0.030	35.93	2.91	2.91	0.076
LDNO 132kV/EHV: HV Site Specific Band 1			2.007	0.293	0.030	924.86	2.91	2.91	0.076
LDNO 132kV/EHV: HV Site Specific Band 2			2.007	0.293	0.030	2738.68	2.91	2.91	0.076
LDNO 132kV/EHV: HV Site Specific Band 3			2.007	0.293	0.030	6002.18	2.91	2.91	0.076
LDNO 132kV/EHV: HV Site Specific Band 4			2.007	0.293	0.030	11495.77	2.91	2.91	0.076
LDNO 132kV/EHV: Unmetered Supplies			5.701	0.889	0.482				
LDNO 132kV/EHV: LV Generation Aggregated			-2.920	-0.631	-0.085	0.00			
LDNO 132kV/EHV: LV Sub Generation Aggregated			-2.774	-0.566	-0.074	0.00			
LDNO 132kV/EHV: LV Generation Site Specific			-2.920	-0.631	-0.085	0.00			0.160
LDNO 132kV/EHV: LV Sub Generation Site Specific			-2.774	-0.566	-0.074	0.00			0.154
LDNO 132kV/EHV: HV Generation Site Specific			-3.755	-0.598	-0.069	47.82			0.237
LDNO 132kV: Domestic Aggregated or CT with Residual			1.108	0.240	0.032	1.74			
LDNO 132kV: Domestic Aggregated (related MPAN)			1.108	0.240	0.032				
LDNO 132kV: Non-Domestic Aggregated or CT No Residual			1.154	0.250	0.034	0.49			

Tariff name	Unique billing identifier	PCs	Red/black unit charge p/kWh	Amber/yellow unit charge p/kWh	Green unit charge p/kWh	Fixed charge p/MPAN/day	Capacity charge p/kVA/day	Exceeded capacity charge p/kVA/day	Reactive power charge p/kVArh
LDNO 132kV: Non-Domestic Aggregated or CT Band 1			1.154	0.250	0.034	2.16			
LDNO 132kV: Non-Domestic Aggregated or CT Band 2			1.154	0.250	0.034	3.79			
LDNO 132kV: Non-Domestic Aggregated or CT Band 3			1.154	0.250	0.034	7.45			
LDNO 132kV: Non-Domestic Aggregated or CT Band 4			1.154	0.250	0.034	20.66			
LDNO 132kV: Non-Domestic Aggregated (related MPAN)			1.154	0.250	0.034				
LDNO 132kV: LV Site Specific No Residual			0.836	0.165	0.021	1.60	0.48	0.48	0.045
LDNO 132kV: LV Site Specific Band 1			0.836	0.165	0.021	40.54	0.48	0.48	0.045
LDNO 132kV: LV Site Specific Band 2			0.836	0.165	0.021	75.15	0.48	0.48	0.045
LDNO 132kV: LV Site Specific Band 3			0.836	0.165	0.021	118.21	0.48	0.48	0.045
LDNO 132kV: LV Site Specific Band 4			0.836	0.165	0.021	270.16	0.48	0.48	0.045
LDNO 132kV: LV Sub Site Specific No Residual			0.997	0.159	0.018	0.93	1.22	1.22	0.041
LDNO 132kV: LV Sub Site Specific Band 1			0.997	0.159	0.018	64.95	1.22	1.22	0.041
LDNO 132kV: LV Sub Site Specific Band 2			0.997	0.159	0.018	121.84	1.22	1.22	0.041
LDNO 132kV: LV Sub Site Specific Band 3			0.997	0.159	0.018	192.62	1.22	1.22	0.041
LDNO 132kV: LV Sub Site Specific Band 4			0.997	0.159	0.018	442.42	1.22	1.22	0.041
LDNO 132kV: HV Site Specific No Residual			0.873	0.128	0.013	15.63	1.27	1.27	0.033
LDNO 132kV: HV Site Specific Band 1			0.873	0.128	0.013	402.29	1.27	1.27	0.033
LDNO 132kV: HV Site Specific Band 2			0.873	0.128	0.013	1191.26	1.27	1.27	0.033
LDNO 132kV: HV Site Specific Band 3			0.873	0.128	0.013	2610.80	1.27	1.27	0.033
LDNO 132kV: HV Site Specific Band 4			0.873	0.128	0.013	5000.38	1.27	1.27	0.033
LDNO 132kV: Unmetered Supplies			2.480	0.387	0.210				
LDNO 132kV: LV Generation Aggregated			-1.270	-0.275	-0.037	0.00			
LDNO 132kV: LV Sub Generation Aggregated			-1.207	-0.246	-0.032	0.00			
LDNO 132kV: LV Generation Site Specific			-1.270	-0.275	-0.037	0.00			0.070
LDNO 132kV: LV Sub Generation Site Specific			-1.207	-0.246	-0.032	0.00			0.067
LDNO 132kV: HV Generation Site Specific			-1.633	-0.260	-0.030	20.80			0.103
LDNO 0000: Domestic Aggregated or CT with Residual			0.000	0.000	0.000	0.00			
LDNO 0000: Domestic Aggregated (related MPAN)			0.000	0.000	0.000				
LDNO 0000: Non-Domestic Aggregated or CT No Residual			0.000	0.000	0.000	0.00			
LDNO 0000: Non-Domestic Aggregated or CT Band 1			0.000	0.000	0.000	0.00			
LDNO 0000: Non-Domestic Aggregated or CT Band 2			0.000	0.000	0.000	0.00			
LDNO 0000: Non-Domestic Aggregated or CT Band 3			0.000	0.000	0.000	0.00			

Tariff name	Unique billing identifier	PCs	Red/black unit charge p/kWh	Amber/yellow unit charge p/kWh	Green unit charge p/kWh	Fixed charge p/MPAN/day	Capacity charge p/kVA/day	Exceeded capacity charge p/kVA/day	Reactive power charge p/kVArh
LDNO 0000: Non-Domestic Aggregated or CT Band 4			0.000	0.000	0.000	0.00			
LDNO 0000: Non-Domestic Aggregated (related MPAN)			0.000	0.000	0.000				
LDNO 0000: LV Site Specific No Residual			0.000	0.000	0.000	0.00	0.00	0.00	0.000
LDNO 0000: LV Site Specific Band 1			0.000	0.000	0.000	0.00	0.00	0.00	0.000
LDNO 0000: LV Site Specific Band 2			0.000	0.000	0.000	0.00	0.00	0.00	0.000
LDNO 0000: LV Site Specific Band 3			0.000	0.000	0.000	0.00	0.00	0.00	0.000
LDNO 0000: LV Site Specific Band 4			0.000	0.000	0.000	0.00	0.00	0.00	0.000
LDNO 0000: LV Sub Site Specific No Residual			0.000	0.000	0.000	0.00	0.00	0.00	0.000
LDNO 0000: LV Sub Site Specific Band 1			0.000	0.000	0.000	0.00	0.00	0.00	0.000
LDNO 0000: LV Sub Site Specific Band 2			0.000	0.000	0.000	0.00	0.00	0.00	0.000
LDNO 0000: LV Sub Site Specific Band 3			0.000	0.000	0.000	0.00	0.00	0.00	0.000
LDNO 0000: LV Sub Site Specific Band 4			0.000	0.000	0.000	0.00	0.00	0.00	0.000
LDNO 0000: HV Site Specific No Residual			0.000	0.000	0.000	0.00	0.00	0.00	0.000
LDNO 0000: HV Site Specific Band 1			0.000	0.000	0.000	0.00	0.00	0.00	0.000
LDNO 0000: HV Site Specific Band 2			0.000	0.000	0.000	0.00	0.00	0.00	0.000
LDNO 0000: HV Site Specific Band 3			0.000	0.000	0.000	0.00	0.00	0.00	0.000
LDNO 0000: HV Site Specific Band 4			0.000	0.000	0.000	0.00	0.00	0.00	0.000
LDNO 0000: Unmetered Supplies			0.000	0.000	0.000				
LDNO 0000: LV Generation Aggregated			0.000	0.000	0.000	0.00			
LDNO 0000: LV Sub Generation Aggregated			0.000	0.000	0.000	0.00			
LDNO 0000: LV Generation Site Specific			0.000	0.000	0.000	0.00			0.000
LDNO 0000: LV Sub Generation Site Specific			0.000	0.000	0.000	0.00			0.000
LDNO 0000: HV Generation Site Specific			0.000	0.000	0.000	0.00			0.000

## Annex 4 - Charges applied to LDNOs with HV/LV end users in “NGED West Midlands Area (GSP Group \_E)”

### Southern Electric Power Distribution plc - Effective from 1st April 2027 - Final LDNO tariffs in NGED West Midlands Area (GSP Group \_E)

Time Bands for LV and HV Properties			
Time periods	Red Time Band	Amber Time Band	Green Time Band
Monday to Friday (Including Bank Holidays) All Year	16:00 to 19:00	07:30 to 16:00 19:00 to 21:00	00:00 to 07:30 21:00 to 24:00
Saturday and Sunday All Year			00:00 to 24:00
Notes	All the above times are in UK Clock time		

Time Bands for Unmetered Properties			
	Black Time Band	Yellow Time Band	Green Time Band
Monday to Friday (Including Bank Holidays) Nov to Feb Inclusive	16:00 to 19:00	07:30 to 16:00 19:00 to 21:00	00:00 to 07:30 21:00 to 24:00
Monday to Friday (Including Bank Holidays) Mar to Oct Inclusive		07:30 to 21:00	00:00 to 07:30 21:00 to 24:00
Saturday and Sunday All Year			00:00 to 24:00
Notes	All the above times are in UK Clock time		

Tariff name	Unique billing identifier	PCs	Red/black unit charge p/kWh	Amber/yellow unit charge p/kWh	Green unit charge p/kWh	Fixed charge p/MPAN/day	Capacity charge p/kVA/day	Exceeded capacity charge p/kVA/day	Reactive power charge p/kVArh
LDNO LV: Domestic Aggregated or CT with Residual		0, 1, 2	7.675	0.965	0.119	10.66			
LDNO LV: Domestic Aggregated (related MPAN)		2	7.675	0.965	0.119				
LDNO LV: Non-Domestic Aggregated or CT No Residual		0, 3, 4, 5-8	6.934	0.872	0.108	9.82			
LDNO LV: Non-Domestic Aggregated or CT Band 1		0, 3, 4, 5-8	6.934	0.872	0.108	12.58			
LDNO LV: Non-Domestic Aggregated or CT Band 2		0, 3, 4, 5-8	6.934	0.872	0.108	20.49			
LDNO LV: Non-Domestic Aggregated or CT Band 3		0, 3, 4, 5-8	6.934	0.872	0.108	32.78			
LDNO LV: Non-Domestic Aggregated or CT Band 4		0, 3, 4, 5-8	6.934	0.872	0.108	69.22			
LDNO LV: Non-Domestic Aggregated (related MPAN)		4	6.934	0.872	0.108				
LDNO LV: LV Site Specific No Residual		0	4.429	0.550	0.061	9.82	7.12	7.12	0.096
LDNO LV: LV Site Specific Band 1		0	4.429	0.550	0.061	109.65	7.12	7.12	0.096
LDNO LV: LV Site Specific Band 2		0	4.429	0.550	0.061	187.15	7.12	7.12	0.096
LDNO LV: LV Site Specific Band 3		0	4.429	0.550	0.061	288.47	7.12	7.12	0.096

Tariff name	Unique billing identifier	PCs	Red/black unit charge p/kWh	Amber/yellow unit charge p/kWh	Green unit charge p/kWh	Fixed charge p/MPAN/day	Capacity charge p/kVA/day	Exceeded capacity charge p/kVA/day	Reactive power charge p/kVArh
LDNO LV: LV Site Specific Band 4		0	4.429	0.550	0.061	514.35	7.12	7.12	0.096
LDNO LV: Unmetered Supplies		0, 1 or 8	27.606	2.122	1.267				
LDNO LV: LV Generation Aggregated		0	-7.505	-0.944	-0.117	0.00			
LDNO LV: LV Generation Site Specific		0	-7.505	-0.944	-0.117	0.00			0.209
LDNO HV: Domestic Aggregated or CT with Residual		0, 1, 2	5.927	0.745	0.092	8.23			
LDNO HV: Domestic Aggregated (Related MPAN)		2	5.927	0.745	0.092				
LDNO HV: Non-Domestic Aggregated or CT No Residual		0, 3, 4, 5-8	5.355	0.673	0.083	7.59			
LDNO HV: Non-Domestic Aggregated or CT Band 1		0, 3, 4, 5-8	5.355	0.673	0.083	9.71			
LDNO HV: Non-Domestic Aggregated or CT Band 2		0, 3, 4, 5-8	5.355	0.673	0.083	15.82			
LDNO HV: Non-Domestic Aggregated or CT Band 3		0, 3, 4, 5-8	5.355	0.673	0.083	25.31			
LDNO HV: Non-Domestic Aggregated or CT Band 4		0, 3, 4, 5-8	5.355	0.673	0.083	53.46			
LDNO HV: Non-Domestic Aggregated (related MPAN)		4	5.355	0.673	0.083				
LDNO HV: LV Site Specific No Residual		0	3.420	0.425	0.047	7.58	5.50	5.50	0.074
LDNO HV: LV Site Specific Band 1		0	3.420	0.425	0.047	84.68	5.50	5.50	0.074
LDNO HV: LV Site Specific Band 2		0	3.420	0.425	0.047	144.54	5.50	5.50	0.074
LDNO HV: LV Site Specific Band 3		0	3.420	0.425	0.047	222.79	5.50	5.50	0.074
LDNO HV: LV Site Specific Band 4		0	3.420	0.425	0.047	397.24	5.50	5.50	0.074
LDNO HV: LV Sub Site Specific No Residual		0	3.062	0.367	0.026	9.65	7.69	7.69	0.065
LDNO HV: LV Sub Site Specific Band 1		0	3.062	0.367	0.026	135.37	7.69	7.69	0.065
LDNO HV: LV Sub Site Specific Band 2		0	3.062	0.367	0.026	232.97	7.69	7.69	0.065
LDNO HV: LV Sub Site Specific Band 3		0	3.062	0.367	0.026	360.57	7.69	7.69	0.065
LDNO HV: LV Sub Site Specific Band 4		0	3.062	0.367	0.026	645.03	7.69	7.69	0.065
LDNO HV: HV Site Specific No Residual		0	1.722	0.195	0.010	102.14	8.88	8.88	0.033
LDNO HV: HV Site Specific Band 1		0	1.722	0.195	0.010	979.68	8.88	8.88	0.033
LDNO HV: HV Site Specific Band 2		0	1.722	0.195	0.010	2739.47	8.88	8.88	0.033
LDNO HV: HV Site Specific Band 3		0	1.722	0.195	0.010	5357.49	8.88	8.88	0.033
LDNO HV: HV Site Specific Band 4		0	1.722	0.195	0.010	12021.82	8.88	8.88	0.033
LDNO HV: Unmetered Supplies		0, 1 or 8	21.321	1.639	0.979				
LDNO HV: LV Generation Aggregated		0	-7.505	-0.944	-0.117	0.00			
LDNO HV: LV Sub Generation Aggregated		0	-5.915	-0.738	-0.085	0.00			
LDNO HV: LV Generation Site Specific		0	-7.505	-0.944	-0.117	0.00			0.209
LDNO HV: LV Sub Generation Site Specific		0	-5.915	-0.738	-0.085	0.00			0.140
LDNO HV: HV Generation Site Specific		0	-2.889	-0.346	-0.024	0.00			0.110

Tariff name	Unique billing identifier	PCs	Red/black unit charge p/kWh	Amber/yellow unit charge p/kWh	Green unit charge p/kWh	Fixed charge p/MPAN/day	Capacity charge p/kVA/day	Exceeded capacity charge p/kVA/day	Reactive power charge p/kVArh
LDNO HVplus: Domestic Aggregated or CT with Residual		0, 1, 2	4.792	0.602	0.074	6.65			
LDNO HVplus: Domestic Aggregated (related MPAN)		2	4.792	0.602	0.074				
LDNO HVplus: Non-Domestic Aggregated or CT No Residual		0, 3, 4, 5-8	4.329	0.544	0.067	6.13			
LDNO HVplus: Non-Domestic Aggregated or CT Band 1		0, 3, 4, 5-8	4.329	0.544	0.067	7.85			
LDNO HVplus: Non-Domestic Aggregated or CT Band 2		0, 3, 4, 5-8	4.329	0.544	0.067	12.79			
LDNO HVplus: Non-Domestic Aggregated or CT Band 3		0, 3, 4, 5-8	4.329	0.544	0.067	20.46			
LDNO HVplus: Non-Domestic Aggregated or CT Band 4		0, 3, 4, 5-8	4.329	0.544	0.067	43.22			
LDNO HVplus: Non-Domestic Aggregated (related MPAN)		4	4.329	0.544	0.067				
LDNO HVplus: LV Site Specific No Residual		0	2.765	0.344	0.038	6.13	4.45	4.45	0.060
LDNO HVplus: LV Site Specific Band 1		0	2.765	0.344	0.038	68.46	4.45	4.45	0.060
LDNO HVplus: LV Site Specific Band 2		0	2.765	0.344	0.038	116.85	4.45	4.45	0.060
LDNO HVplus: LV Site Specific Band 3		0	2.765	0.344	0.038	180.11	4.45	4.45	0.060
LDNO HVplus: LV Site Specific Band 4		0	2.765	0.344	0.038	321.14	4.45	4.45	0.060
LDNO HVplus: LV Sub Site Specific No Residual		0	2.418	0.290	0.020	7.62	6.08	6.08	0.052
LDNO HVplus: LV Sub Site Specific Band 1		0	2.418	0.290	0.020	106.92	6.08	6.08	0.052
LDNO HVplus: LV Sub Site Specific Band 2		0	2.418	0.290	0.020	184.01	6.08	6.08	0.052
LDNO HVplus: LV Sub Site Specific Band 3		0	2.418	0.290	0.020	284.79	6.08	6.08	0.052
LDNO HVplus: LV Sub Site Specific Band 4		0	2.418	0.290	0.020	509.47	6.08	6.08	0.052
LDNO HVplus: HV Site Specific No Residual		0	1.346	0.152	0.008	79.87	6.95	6.95	0.026
LDNO HVplus: HV Site Specific Band 1		0	1.346	0.152	0.008	766.07	6.95	6.95	0.026
LDNO HVplus: HV Site Specific Band 2		0	1.346	0.152	0.008	2142.15	6.95	6.95	0.026
LDNO HVplus: HV Site Specific Band 3		0	1.346	0.152	0.008	4189.34	6.95	6.95	0.026
LDNO HVplus: HV Site Specific Band 4		0	1.346	0.152	0.008	9400.56	6.95	6.95	0.026
LDNO HVplus: Unmetered Supplies		0, 1 or 8	17.236	1.325	0.791				
LDNO HVplus: LV Generation Aggregated		0	-4.743	-0.596	-0.074	0.00			
LDNO HVplus: LV Sub Generation Aggregated		0	-4.241	-0.529	-0.061	0.00			
LDNO HVplus: LV Generation Site Specific		0	-4.743	-0.596	-0.074	0.00			0.132
LDNO HVplus: LV Sub Generation Site Specific		0	-4.241	-0.529	-0.061	0.00			0.100

Tariff name	Unique billing identifier	PCs	Red/black unit charge p/kWh	Amber/yellow unit charge p/kWh	Green unit charge p/kWh	Fixed charge p/MPAN/day	Capacity charge p/kVA/day	Exceeded capacity charge p/kVA/day	Reactive power charge p/kVArh
LDNO HVplus: HV Generation Site Specific		0	-2.889	-0.346	-0.024	69.71			0.110
LDNO EHV: Domestic Aggregated or CT with Residual		0, 1, 2	3.873	0.487	0.060	5.38			
LDNO EHV: Domestic Aggregated (related MPAN)		2	3.873	0.487	0.060				
LDNO EHV: Non-Domestic Aggregated or CT No Residual		0, 3, 4, 5-8	3.500	0.440	0.054	4.96			
LDNO EHV: Non-Domestic Aggregated or CT Band 1		0, 3, 4, 5-8	3.500	0.440	0.054	6.35			
LDNO EHV: Non-Domestic Aggregated or CT Band 2		0, 3, 4, 5-8	3.500	0.440	0.054	10.34			
LDNO EHV: Non-Domestic Aggregated or CT Band 3		0, 3, 4, 5-8	3.500	0.440	0.054	16.54			
LDNO EHV: Non-Domestic Aggregated or CT Band 4		0, 3, 4, 5-8	3.500	0.440	0.054	34.94			
LDNO EHV: Non-Domestic Aggregated (related MPAN)		4	3.500	0.440	0.054				
LDNO EHV: LV Site Specific No Residual		0	2.235	0.278	0.031	4.96	3.59	3.59	0.049
LDNO EHV: LV Site Specific Band 1		0	2.235	0.278	0.031	55.34	3.59	3.59	0.049
LDNO EHV: LV Site Specific Band 2		0	2.235	0.278	0.031	94.46	3.59	3.59	0.049
LDNO EHV: LV Site Specific Band 3		0	2.235	0.278	0.031	145.59	3.59	3.59	0.049
LDNO EHV: LV Site Specific Band 4		0	2.235	0.278	0.031	259.59	3.59	3.59	0.049
LDNO EHV: LV Sub Site Specific No Residual		0	1.955	0.234	0.016	6.16	4.91	4.91	0.042
LDNO EHV: LV Sub Site Specific Band 1		0	1.955	0.234	0.016	86.43	4.91	4.91	0.042
LDNO EHV: LV Sub Site Specific Band 2		0	1.955	0.234	0.016	148.75	4.91	4.91	0.042
LDNO EHV: LV Sub Site Specific Band 3		0	1.955	0.234	0.016	230.21	4.91	4.91	0.042
LDNO EHV: LV Sub Site Specific Band 4		0	1.955	0.234	0.016	411.84	4.91	4.91	0.042
LDNO EHV: HV Site Specific No Residual		0	1.088	0.123	0.006	64.56	5.62	5.62	0.021
LDNO EHV: HV Site Specific Band 1		0	1.088	0.123	0.006	619.26	5.62	5.62	0.021
LDNO EHV: HV Site Specific Band 2		0	1.088	0.123	0.006	1731.62	5.62	5.62	0.021
LDNO EHV: HV Site Specific Band 3		0	1.088	0.123	0.006	3386.47	5.62	5.62	0.021
LDNO EHV: HV Site Specific Band 4		0	1.088	0.123	0.006	7598.99	5.62	5.62	0.021
LDNO EHV: Unmetered Supplies		0, 1 or 8	13.933	1.071	0.639				
LDNO EHV: LV Generation Aggregated		0	-3.834	-0.482	-0.060	0.00			
LDNO EHV: LV Sub Generation Aggregated		0	-3.429	-0.428	-0.049	0.00			
LDNO EHV: LV Generation Site Specific		0	-3.834	-0.482	-0.060	0.00			0.107
LDNO EHV: LV Sub Generation Site Specific		0	-3.429	-0.428	-0.049	0.00			0.081
LDNO EHV: HV Generation Site Specific		0	-2.335	-0.280	-0.019	56.35			0.089
LDNO 132kV/EHV: Domestic Aggregated or CT with Residual		0, 1, 2	3.713	0.467	0.058	5.16			

Tariff name	Unique billing identifier	PCs	Red/black unit charge p/kWh	Amber/yellow unit charge p/kWh	Green unit charge p/kWh	Fixed charge p/MPAN/day	Capacity charge p/kVA/day	Exceeded capacity charge p/kVA/day	Reactive power charge p/kVArh
LDNO 132kV/EHV: Domestic Aggregated (related MPAN)		2	3.713	0.467	0.058				
LDNO 132kV/EHV: Non-Domestic Aggregated or CT No Residual		0, 3, 4, 5-8	3.355	0.422	0.052	4.75			
LDNO 132kV/EHV: Non-Domestic Aggregated or CT Band 1		0, 3, 4, 5-8	3.355	0.422	0.052	6.08			
LDNO 132kV/EHV: Non-Domestic Aggregated or CT Band 2		0, 3, 4, 5-8	3.355	0.422	0.052	9.91			
LDNO 132kV/EHV: Non-Domestic Aggregated or CT Band 3		0, 3, 4, 5-8	3.355	0.422	0.052	15.86			
LDNO 132kV/EHV: Non-Domestic Aggregated or CT Band 4		0, 3, 4, 5-8	3.355	0.422	0.052	33.49			
LDNO 132kV/EHV: Non-Domestic Aggregated (related MPAN)		4	3.355	0.422	0.052				
LDNO 132kV/EHV: LV Site Specific No Residual		0	2.143	0.266	0.029	4.75	3.45	3.45	0.047
LDNO 132kV/EHV: LV Site Specific Band 1		0	2.143	0.266	0.029	53.05	3.45	3.45	0.047
LDNO 132kV/EHV: LV Site Specific Band 2		0	2.143	0.266	0.029	90.54	3.45	3.45	0.047
LDNO 132kV/EHV: LV Site Specific Band 3		0	2.143	0.266	0.029	139.56	3.45	3.45	0.047
LDNO 132kV/EHV: LV Site Specific Band 4		0	2.143	0.266	0.029	248.84	3.45	3.45	0.047
LDNO 132kV/EHV: LV Sub Site Specific No Residual		0	1.874	0.225	0.016	5.91	4.71	4.71	0.040
LDNO 132kV/EHV: LV Sub Site Specific Band 1		0	1.874	0.225	0.016	82.85	4.71	4.71	0.040
LDNO 132kV/EHV: LV Sub Site Specific Band 2		0	1.874	0.225	0.016	142.58	4.71	4.71	0.040
LDNO 132kV/EHV: LV Sub Site Specific Band 3		0	1.874	0.225	0.016	220.67	4.71	4.71	0.040
LDNO 132kV/EHV: LV Sub Site Specific Band 4		0	1.874	0.225	0.016	394.77	4.71	4.71	0.040
LDNO 132kV/EHV: HV Site Specific No Residual		0	1.043	0.118	0.006	61.88	5.38	5.38	0.020
LDNO 132kV/EHV: HV Site Specific Band 1		0	1.043	0.118	0.006	593.59	5.38	5.38	0.020
LDNO 132kV/EHV: HV Site Specific Band 2		0	1.043	0.118	0.006	1659.85	5.38	5.38	0.020
LDNO 132kV/EHV: HV Site Specific Band 3		0	1.043	0.118	0.006	3246.11	5.38	5.38	0.020
LDNO 132kV/EHV: HV Site Specific Band 4		0	1.043	0.118	0.006	7284.03	5.38	5.38	0.020
LDNO 132kV/EHV: Unmetered Supplies		0, 1 or 8	13.355	1.027	0.613				
LDNO 132kV/EHV: LV Generation Aggregated		0	-3.675	-0.462	-0.057	0.00			
LDNO 132kV/EHV: LV Sub Generation Aggregated		0	-3.286	-0.410	-0.047	0.00			
LDNO 132kV/EHV: LV Generation Site Specific		0	-3.675	-0.462	-0.057	0.00			0.102
LDNO 132kV/EHV: LV Sub Generation Site Specific		0	-3.286	-0.410	-0.047	0.00			0.078
LDNO 132kV/EHV: HV Generation Site Specific		0	-2.238	-0.268	-0.019	54.01			0.085

Tariff name	Unique billing identifier	PCs	Red/black unit charge p/kWh	Amber/yellow unit charge p/kWh	Green unit charge p/kWh	Fixed charge p/MPAN/day	Capacity charge p/kVA/day	Exceeded capacity charge p/kVA/day	Reactive power charge p/kVArh
LDNO 132kV: Domestic Aggregated or CT with Residual		0, 1, 2	2.436	0.306	0.038	3.38			
LDNO 132kV: Domestic Aggregated (related MPAN)		2	2.436	0.306	0.038				
LDNO 132kV: Non-Domestic Aggregated or CT No Residual		0, 3, 4, 5-8	2.201	0.277	0.034	3.12			
LDNO 132kV: Non-Domestic Aggregated or CT Band 1		0, 3, 4, 5-8	2.201	0.277	0.034	3.99			
LDNO 132kV: Non-Domestic Aggregated or CT Band 2		0, 3, 4, 5-8	2.201	0.277	0.034	6.50			
LDNO 132kV: Non-Domestic Aggregated or CT Band 3		0, 3, 4, 5-8	2.201	0.277	0.034	10.40			
LDNO 132kV: Non-Domestic Aggregated or CT Band 4		0, 3, 4, 5-8	2.201	0.277	0.034	21.97			
LDNO 132kV: Non-Domestic Aggregated (related MPAN)		4	2.201	0.277	0.034				
LDNO 132kV: LV Site Specific No Residual		0	1.405	0.175	0.019	3.12	2.26	2.26	0.031
LDNO 132kV: LV Site Specific Band 1		0	1.405	0.175	0.019	34.80	2.26	2.26	0.031
LDNO 132kV: LV Site Specific Band 2		0	1.405	0.175	0.019	59.39	2.26	2.26	0.031
LDNO 132kV: LV Site Specific Band 3		0	1.405	0.175	0.019	91.55	2.26	2.26	0.031
LDNO 132kV: LV Site Specific Band 4		0	1.405	0.175	0.019	163.23	2.26	2.26	0.031
LDNO 132kV: LV Sub Site Specific No Residual		0	1.229	0.147	0.010	3.88	3.09	3.09	0.026
LDNO 132kV: LV Sub Site Specific Band 1		0	1.229	0.147	0.010	54.35	3.09	3.09	0.026
LDNO 132kV: LV Sub Site Specific Band 2		0	1.229	0.147	0.010	93.53	3.09	3.09	0.026
LDNO 132kV: LV Sub Site Specific Band 3		0	1.229	0.147	0.010	144.75	3.09	3.09	0.026
LDNO 132kV: LV Sub Site Specific Band 4		0	1.229	0.147	0.010	258.96	3.09	3.09	0.026
LDNO 132kV: HV Site Specific No Residual		0	0.684	0.077	0.004	40.59	3.53	3.53	0.013
LDNO 132kV: HV Site Specific Band 1		0	0.684	0.077	0.004	389.38	3.53	3.53	0.013
LDNO 132kV: HV Site Specific Band 2		0	0.684	0.077	0.004	1088.81	3.53	3.53	0.013
LDNO 132kV: HV Site Specific Band 3		0	0.684	0.077	0.004	2129.36	3.53	3.53	0.013
LDNO 132kV: HV Site Specific Band 4		0	0.684	0.077	0.004	4778.12	3.53	3.53	0.013
LDNO 132kV: Unmetered Supplies		0, 1 or 8	8.761	0.673	0.402				
LDNO 132kV: LV Generation Aggregated		0	-2.411	-0.303	-0.037	0.00			
LDNO 132kV: LV Sub Generation Aggregated		0	-2.156	-0.269	-0.031	0.00			
LDNO 132kV: LV Generation Site Specific		0	-2.411	-0.303	-0.037	0.00			0.067
LDNO 132kV: LV Sub Generation Site Specific		0	-2.156	-0.269	-0.031	0.00			0.051
LDNO 132kV: HV Generation Site Specific		0	-1.468	-0.176	-0.012	35.43			0.056
LDNO 0000: Domestic Aggregated or CT with Residual		0, 1, 2	0.520	0.065	0.008	0.72			
LDNO 0000: Domestic Aggregated (related MPAN)		2	0.520	0.065	0.008				

Tariff name	Unique billing identifier	PCs	Red/black unit charge p/kWh	Amber/yellow unit charge p/kWh	Green unit charge p/kWh	Fixed charge p/MPAN/day	Capacity charge p/kVA/day	Exceeded capacity charge p/kVA/day	Reactive power charge p/kVArh
LDNO 0000: Non-Domestic Aggregated or CT No Residual		0, 3, 4, 5-8	0.469	0.059	0.007	0.66			
LDNO 0000: Non-Domestic Aggregated or CT Band 1		0, 3, 4, 5-8	0.469	0.059	0.007	0.85			
LDNO 0000: Non-Domestic Aggregated or CT Band 2		0, 3, 4, 5-8	0.469	0.059	0.007	1.39			
LDNO 0000: Non-Domestic Aggregated or CT Band 3		0, 3, 4, 5-8	0.469	0.059	0.007	2.22			
LDNO 0000: Non-Domestic Aggregated or CT Band 4		0, 3, 4, 5-8	0.469	0.059	0.007	4.69			
LDNO 0000: Non-Domestic Aggregated (related MPAN)		4	0.469	0.059	0.007				
LDNO 0000: LV Site Specific No Residual		0	0.300	0.037	0.004	0.66	0.48	0.48	0.007
LDNO 0000: LV Site Specific Band 1		0	0.300	0.037	0.004	7.42	0.48	0.48	0.007
LDNO 0000: LV Site Specific Band 2		0	0.300	0.037	0.004	12.67	0.48	0.48	0.007
LDNO 0000: LV Site Specific Band 3		0	0.300	0.037	0.004	19.53	0.48	0.48	0.007
LDNO 0000: LV Site Specific Band 4		0	0.300	0.037	0.004	34.83	0.48	0.48	0.007
LDNO 0000: LV Sub Site Specific No Residual		0	0.262	0.031	0.002	0.83	0.66	0.66	0.006
LDNO 0000: LV Sub Site Specific Band 1		0	0.262	0.031	0.002	11.60	0.66	0.66	0.006
LDNO 0000: LV Sub Site Specific Band 2		0	0.262	0.031	0.002	19.96	0.66	0.66	0.006
LDNO 0000: LV Sub Site Specific Band 3		0	0.262	0.031	0.002	30.88	0.66	0.66	0.006
LDNO 0000: LV Sub Site Specific Band 4		0	0.262	0.031	0.002	55.25	0.66	0.66	0.006
LDNO 0000: HV Site Specific No Residual		0	0.146	0.017	0.001	8.66	0.75	0.75	0.003
LDNO 0000: HV Site Specific Band 1		0	0.146	0.017	0.001	83.08	0.75	0.75	0.003
LDNO 0000: HV Site Specific Band 2		0	0.146	0.017	0.001	232.30	0.75	0.75	0.003
LDNO 0000: HV Site Specific Band 3		0	0.146	0.017	0.001	454.31	0.75	0.75	0.003
LDNO 0000: HV Site Specific Band 4		0	0.146	0.017	0.001	1019.43	0.75	0.75	0.003
LDNO 0000: Unmetered Supplies		0, 1 or 8	1.869	0.144	0.086				
LDNO 0000: LV Generation Aggregated		0	-0.514	-0.065	-0.008	0.00			
LDNO 0000: LV Sub Generation Aggregated		0	-0.460	-0.057	-0.007	0.00			
LDNO 0000: LV Generation Site Specific		0	-0.514	-0.065	-0.008	0.00			0.014
LDNO 0000: LV Sub Generation Site Specific		0	-0.460	-0.057	-0.007	0.00			0.011
LDNO 0000: HV Generation Site Specific		0	-0.313	-0.038	-0.003	7.56			0.012

## Annex 4 - Charges applied to LDNOs with HV/LV end users in “Northern Powergrid (Northeast) Area (GSP Group \_F)”

### Southern Electric Power Distribution plc - Effective from 1st April 2027 - Final LDNO tariffs in NPG Northeast Area (GSP Group \_F)

Time Bands for LV and HV Properties			
Time periods	Red Time Band	Amber Time Band	Green Time Band
Monday to Friday (Including Bank Holidays) All Year	16:00 to 19:30	08:00 to 16:00 19:30 to 22:00	00:00 to 08:00 22:00 to 24:00
Saturday and Sunday All Year			00:00 to 24:00
Notes	All the above times are in UK Clock time		

Time Bands for Unmetered Properties			
	Black Time Band	Yellow Time Band	Green Time Band
Monday to Friday (Including Bank Holidays) November to February Inclusive	16:00 to 19:30	08:00 to 16:00 19:30 to 22:00	00:00 to 08:00 22:00 to 24:00
Monday to Friday (Including Bank Holidays) April to October Inclusive and March		08:00 to 22:00	00:00 to 08:00 22:00 to 24:00
Saturday and Sunday All year			00:00 to 24:00
Notes	All the above times are in UK Clock time		

Tariff name	Unique billing identifier	PCs	Red/black unit charge p/kWh	Amber/yellow unit charge p/kWh	Green unit charge p/kWh	Fixed charge p/MPAN/day	Capacity charge p/kVA/day	Exceeded capacity charge p/kVA/day	Reactive power charge p/kVArh
LDNO LV: Domestic Aggregated or CT with Residual		0, 1, 2	6.580	1.063	0.180	12.65			
LDNO LV: Domestic Aggregated (related MPAN)		2	6.580	1.063	0.180				
LDNO LV: Non-Domestic Aggregated or CT No Residual		0, 3, 4, 5-8	7.005	1.132	0.192	8.44			
LDNO LV: Non-Domestic Aggregated or CT Band 1		0, 3, 4, 5-8	7.005	1.132	0.192	12.20			
LDNO LV: Non-Domestic Aggregated or CT Band 2		0, 3, 4, 5-8	7.005	1.132	0.192	18.16			
LDNO LV: Non-Domestic Aggregated or CT Band 3		0, 3, 4, 5-8	7.005	1.132	0.192	29.20			
LDNO LV: Non-Domestic Aggregated or CT Band 4		0, 3, 4, 5-8	7.005	1.132	0.192	64.65			
LDNO LV: Non-Domestic Aggregated (related MPAN)		4	7.005	1.132	0.192				
LDNO LV: LV Site Specific No Residual		0	4.900	0.759	0.130	8.58	3.24	3.24	0.088
LDNO LV: LV Site Specific Band 1		0	4.900	0.759	0.130	102.08	3.24	3.24	0.088
LDNO LV: LV Site Specific Band 2		0	4.900	0.759	0.130	208.99	3.24	3.24	0.088
LDNO LV: LV Site Specific Band 3		0	4.900	0.759	0.130	334.91	3.24	3.24	0.088
LDNO LV: LV Site Specific Band 4		0	4.900	0.759	0.130	863.81	3.24	3.24	0.088

Tariff name	Unique billing identifier	PCs	Red/black unit charge p/kWh	Amber/yellow unit charge p/kWh	Green unit charge p/kWh	Fixed charge p/MPAN/day	Capacity charge p/kVA/day	Exceeded capacity charge p/kVA/day	Reactive power charge p/kVArh
LDNO LV: Unmetered Supplies		0, 1, 8	18.896	1.295	0.597				
LDNO LV: LV Generation Aggregated		0, 8	-7.719	-1.247	-0.211				
LDNO LV: LV Generation Site Specific		0	-7.719	-1.247	-0.211				0.122
LDNO HV: Domestic Aggregated or CT with Residual		0, 1, 2	4.422	0.714	0.121	8.50			
LDNO HV: Domestic Aggregated (Related MPAN)		2	4.422	0.714	0.121				
LDNO HV: Non-Domestic Aggregated or CT No Residual		0, 3, 4, 5-8	4.707	0.760	0.129	5.67			
LDNO HV: Non-Domestic Aggregated or CT Band 1		0, 3, 4, 5-8	4.707	0.760	0.129	8.20			
LDNO HV: Non-Domestic Aggregated or CT Band 2		0, 3, 4, 5-8	4.707	0.760	0.129	12.21			
LDNO HV: Non-Domestic Aggregated or CT Band 3		0, 3, 4, 5-8	4.707	0.760	0.129	19.62			
LDNO HV: Non-Domestic Aggregated or CT Band 4		0, 3, 4, 5-8	4.707	0.760	0.129	43.45			
LDNO HV: Non-Domestic Aggregated (related MPAN)		4	4.707	0.760	0.129				
LDNO HV: LV Site Specific No Residual		0	3.293	0.510	0.088	5.77	2.18	2.18	0.059
LDNO HV: LV Site Specific Band 1		0	3.293	0.510	0.088	68.60	2.18	2.18	0.059
LDNO HV: LV Site Specific Band 2		0	3.293	0.510	0.088	140.45	2.18	2.18	0.059
LDNO HV: LV Site Specific Band 3		0	3.293	0.510	0.088	225.08	2.18	2.18	0.059
LDNO HV: LV Site Specific Band 4		0	3.293	0.510	0.088	580.53	2.18	2.18	0.059
LDNO HV: LV Sub Site Specific No Residual		0	3.266	0.446	0.080	10.13	3.58	3.58	0.055
LDNO HV: LV Sub Site Specific Band 1		0	3.266	0.446	0.080	120.55	3.58	3.58	0.055
LDNO HV: LV Sub Site Specific Band 2		0	3.266	0.446	0.080	246.81	3.58	3.58	0.055
LDNO HV: LV Sub Site Specific Band 3		0	3.266	0.446	0.080	395.51	3.58	3.58	0.055
LDNO HV: LV Sub Site Specific Band 4		0	3.266	0.446	0.080	1020.11	3.58	3.58	0.055
LDNO HV: HV Site Specific No Residual		0	2.961	0.359	0.068	258.50	4.95	4.95	0.049
LDNO HV: HV Site Specific Band 1		0	2.961	0.359	0.068	1405.33	4.95	4.95	0.049
LDNO HV: HV Site Specific Band 2		0	2.961	0.359	0.068	3070.65	4.95	4.95	0.049
LDNO HV: HV Site Specific Band 3		0	2.961	0.359	0.068	5561.28	4.95	4.95	0.049
LDNO HV: HV Site Specific Band 4		0	2.961	0.359	0.068	13639.65	4.95	4.95	0.049
LDNO HV: Unmetered Supplies		0, 1, 8	12.699	0.870	0.401				
LDNO HV: LV Generation Aggregated		0, 8	-7.719	-1.247	-0.211				
LDNO HV: LV Sub Generation Aggregated		8	-6.500	-1.026	-0.175				
LDNO HV: LV Generation Site Specific		0	-7.719	-1.247	-0.211				0.122
LDNO HV: LV Sub Generation Site Specific		0	-6.500	-1.026	-0.175				0.114
LDNO HV: HV Generation Site Specific		0	-4.059	-0.555	-0.100				0.101

Tariff name	Unique billing identifier	PCs	Red/black unit charge p/kWh	Amber/yellow unit charge p/kWh	Green unit charge p/kWh	Fixed charge p/MPAN/day	Capacity charge p/kVA/day	Exceeded capacity charge p/kVA/day	Reactive power charge p/kVArh
LDNO HVplus: Domestic Aggregated or CT with Residual		0, 1, 2	3.093	0.500	0.085	5.94			
LDNO HVplus: Domestic Aggregated (related MPAN)		2	3.093	0.500	0.085				
LDNO HVplus: Non-Domestic Aggregated or CT No Residual		0, 3, 4, 5-8	3.292	0.532	0.090	3.97			
LDNO HVplus: Non-Domestic Aggregated or CT Band 1		0, 3, 4, 5-8	3.292	0.532	0.090	5.74			
LDNO HVplus: Non-Domestic Aggregated or CT Band 2		0, 3, 4, 5-8	3.292	0.532	0.090	8.54			
LDNO HVplus: Non-Domestic Aggregated or CT Band 3		0, 3, 4, 5-8	3.292	0.532	0.090	13.72			
LDNO HVplus: Non-Domestic Aggregated or CT Band 4		0, 3, 4, 5-8	3.292	0.532	0.090	30.39			
LDNO HVplus: Non-Domestic Aggregated (related MPAN)		4	3.292	0.532	0.090				
LDNO HVplus: LV Site Specific No Residual		0	2.303	0.357	0.061	4.03	1.52	1.52	0.041
LDNO HVplus: LV Site Specific Band 1		0	2.303	0.357	0.061	47.98	1.52	1.52	0.041
LDNO HVplus: LV Site Specific Band 2		0	2.303	0.357	0.061	98.22	1.52	1.52	0.041
LDNO HVplus: LV Site Specific Band 3		0	2.303	0.357	0.061	157.40	1.52	1.52	0.041
LDNO HVplus: LV Site Specific Band 4		0	2.303	0.357	0.061	405.98	1.52	1.52	0.041
LDNO HVplus: LV Sub Site Specific No Residual		0	2.254	0.308	0.055	6.99	2.47	2.47	0.038
LDNO HVplus: LV Sub Site Specific Band 1		0	2.254	0.308	0.055	83.18	2.47	2.47	0.038
LDNO HVplus: LV Sub Site Specific Band 2		0	2.254	0.308	0.055	170.30	2.47	2.47	0.038
LDNO HVplus: LV Sub Site Specific Band 3		0	2.254	0.308	0.055	272.91	2.47	2.47	0.038
LDNO HVplus: LV Sub Site Specific Band 4		0	2.254	0.308	0.055	703.90	2.47	2.47	0.038
LDNO HVplus: HV Site Specific No Residual		0	2.022	0.245	0.046	176.49	3.38	3.38	0.033
LDNO HVplus: HV Site Specific Band 1		0	2.022	0.245	0.046	959.50	3.38	3.38	0.033
LDNO HVplus: HV Site Specific Band 2		0	2.022	0.245	0.046	2096.51	3.38	3.38	0.033
LDNO HVplus: HV Site Specific Band 3		0	2.022	0.245	0.046	3797.01	3.38	3.38	0.033
LDNO HVplus: HV Site Specific Band 4		0	2.022	0.245	0.046	9312.59	3.38	3.38	0.033
LDNO HVplus: Unmetered Supplies		0, 1, 8	8.881	0.609	0.281				
LDNO HVplus: LV Generation Aggregated		0, 8	-3.608	-0.583	-0.099				
LDNO HVplus: LV Sub Generation Aggregated		8	-3.693	-0.583	-0.100				
LDNO HVplus: LV Generation Site Specific		0	-3.608	-0.583	-0.099				0.057
LDNO HVplus: LV Sub Generation Site Specific		0	-3.693	-0.583	-0.100				0.065
LDNO HVplus: HV Generation Site Specific		0	-4.059	-0.555	-0.100	69.30			0.101
LDNO EHV: Domestic Aggregated or CT with Residual		0, 1, 2	2.151	0.348	0.059	4.14			
LDNO EHV: Domestic Aggregated (related MPAN)		2	2.151	0.348	0.059				

Tariff name	Unique billing identifier	PCs	Red/black unit charge p/kWh	Amber/yellow unit charge p/kWh	Green unit charge p/kWh	Fixed charge p/MPAN/day	Capacity charge p/kVA/day	Exceeded capacity charge p/kVA/day	Reactive power charge p/kVArh
LDNO EHV: Non-Domestic Aggregated or CT No Residual		0, 3, 4, 5-8	2.290	0.370	0.063	2.76			
LDNO EHV: Non-Domestic Aggregated or CT Band 1		0, 3, 4, 5-8	2.290	0.370	0.063	3.99			
LDNO EHV: Non-Domestic Aggregated or CT Band 2		0, 3, 4, 5-8	2.290	0.370	0.063	5.94			
LDNO EHV: Non-Domestic Aggregated or CT Band 3		0, 3, 4, 5-8	2.290	0.370	0.063	9.55			
LDNO EHV: Non-Domestic Aggregated or CT Band 4		0, 3, 4, 5-8	2.290	0.370	0.063	21.14			
LDNO EHV: Non-Domestic Aggregated (related MPAN)		4	2.290	0.370	0.063				
LDNO EHV: LV Site Specific No Residual		0	1.602	0.248	0.043	2.80	1.06	1.06	0.029
LDNO EHV: LV Site Specific Band 1		0	1.602	0.248	0.043	33.37	1.06	1.06	0.029
LDNO EHV: LV Site Specific Band 2		0	1.602	0.248	0.043	68.33	1.06	1.06	0.029
LDNO EHV: LV Site Specific Band 3		0	1.602	0.248	0.043	109.50	1.06	1.06	0.029
LDNO EHV: LV Site Specific Band 4		0	1.602	0.248	0.043	282.42	1.06	1.06	0.029
LDNO EHV: LV Sub Site Specific No Residual		0	1.568	0.214	0.039	4.86	1.72	1.72	0.027
LDNO EHV: LV Sub Site Specific Band 1		0	1.568	0.214	0.039	57.87	1.72	1.72	0.027
LDNO EHV: LV Sub Site Specific Band 2		0	1.568	0.214	0.039	118.47	1.72	1.72	0.027
LDNO EHV: LV Sub Site Specific Band 3		0	1.568	0.214	0.039	189.85	1.72	1.72	0.027
LDNO EHV: LV Sub Site Specific Band 4		0	1.568	0.214	0.039	489.67	1.72	1.72	0.027
LDNO EHV: HV Site Specific No Residual		0	1.406	0.171	0.032	122.78	2.35	2.35	0.023
LDNO EHV: HV Site Specific Band 1		0	1.406	0.171	0.032	667.48	2.35	2.35	0.023
LDNO EHV: HV Site Specific Band 2		0	1.406	0.171	0.032	1458.44	2.35	2.35	0.023
LDNO EHV: HV Site Specific Band 3		0	1.406	0.171	0.032	2641.40	2.35	2.35	0.023
LDNO EHV: HV Site Specific Band 4		0	1.406	0.171	0.032	6478.32	2.35	2.35	0.023
LDNO EHV: Unmetered Supplies		0, 1, 8	6.178	0.423	0.195				
LDNO EHV: LV Generation Aggregated		0, 8	-2.510	-0.405	-0.069				
LDNO EHV: LV Sub Generation Aggregated		8	-2.569	-0.406	-0.069				
LDNO EHV: LV Generation Site Specific		0	-2.510	-0.405	-0.069				0.040
LDNO EHV: LV Sub Generation Site Specific		0	-2.569	-0.406	-0.069				0.045
LDNO EHV: HV Generation Site Specific		0	-2.824	-0.386	-0.069	48.21			0.070
LDNO 132kV/EHV: Domestic Aggregated or CT with Residual		0, 1, 2	1.427	0.230	0.039	2.74			
LDNO 132kV/EHV: Domestic Aggregated (related MPAN)		2	1.427	0.230	0.039				
LDNO 132kV/EHV: Non-Domestic Aggregated or CT No Residual		0, 3, 4, 5-8	1.519	0.245	0.042	1.83			

Tariff name	Unique billing identifier	PCs	Red/black unit charge p/kWh	Amber/yellow unit charge p/kWh	Green unit charge p/kWh	Fixed charge p/MPAN/day	Capacity charge p/kVA/day	Exceeded capacity charge p/kVA/day	Reactive power charge p/kVArh
LDNO 132kV/EHV: Non-Domestic Aggregated or CT Band 1		0, 3, 4, 5-8	1.519	0.245	0.042	2.65			
LDNO 132kV/EHV: Non-Domestic Aggregated or CT Band 2		0, 3, 4, 5-8	1.519	0.245	0.042	3.94			
LDNO 132kV/EHV: Non-Domestic Aggregated or CT Band 3		0, 3, 4, 5-8	1.519	0.245	0.042	6.33			
LDNO 132kV/EHV: Non-Domestic Aggregated or CT Band 4		0, 3, 4, 5-8	1.519	0.245	0.042	14.02			
LDNO 132kV/EHV: Non-Domestic Aggregated (related MPAN)		4	1.519	0.245	0.042				
LDNO 132kV/EHV: LV Site Specific No Residual		0	1.062	0.165	0.028	1.86	0.70	0.70	0.019
LDNO 132kV/EHV: LV Site Specific Band 1		0	1.062	0.165	0.028	22.13	0.70	0.70	0.019
LDNO 132kV/EHV: LV Site Specific Band 2		0	1.062	0.165	0.028	45.31	0.70	0.70	0.019
LDNO 132kV/EHV: LV Site Specific Band 3		0	1.062	0.165	0.028	72.61	0.70	0.70	0.019
LDNO 132kV/EHV: LV Site Specific Band 4		0	1.062	0.165	0.028	187.29	0.70	0.70	0.019
LDNO 132kV/EHV: LV Sub Site Specific No Residual		0	1.040	0.142	0.026	3.22	1.14	1.14	0.018
LDNO 132kV/EHV: LV Sub Site Specific Band 1		0	1.040	0.142	0.026	38.37	1.14	1.14	0.018
LDNO 132kV/EHV: LV Sub Site Specific Band 2		0	1.040	0.142	0.026	78.57	1.14	1.14	0.018
LDNO 132kV/EHV: LV Sub Site Specific Band 3		0	1.040	0.142	0.026	125.90	1.14	1.14	0.018
LDNO 132kV/EHV: LV Sub Site Specific Band 4		0	1.040	0.142	0.026	324.73	1.14	1.14	0.018
LDNO 132kV/EHV: HV Site Specific No Residual		0	0.933	0.113	0.021	81.42	1.56	1.56	0.015
LDNO 132kV/EHV: HV Site Specific Band 1		0	0.933	0.113	0.021	442.65	1.56	1.56	0.015
LDNO 132kV/EHV: HV Site Specific Band 2		0	0.933	0.113	0.021	967.18	1.56	1.56	0.015
LDNO 132kV/EHV: HV Site Specific Band 3		0	0.933	0.113	0.021	1751.67	1.56	1.56	0.015
LDNO 132kV/EHV: HV Site Specific Band 4		0	0.933	0.113	0.021	4296.16	1.56	1.56	0.015
LDNO 132kV/EHV: Unmetered Supplies		0, 1, 8	4.097	0.281	0.129				
LDNO 132kV/EHV: LV Generation Aggregated		0, 8	-1.664	-0.269	-0.046				
LDNO 132kV/EHV: LV Sub Generation Aggregated		8	-1.704	-0.269	-0.046				
LDNO 132kV/EHV: LV Generation Site Specific		0	-1.664	-0.269	-0.046				0.026
LDNO 132kV/EHV: LV Sub Generation Site Specific		0	-1.704	-0.269	-0.046				0.030
LDNO 132kV/EHV: HV Generation Site Specific		0	-1.872	-0.256	-0.046	31.97			0.047
LDNO 132kV: Domestic Aggregated or CT with Residual		0, 1, 2	0.727	0.117	0.020	1.40			
LDNO 132kV: Domestic Aggregated (related MPAN)		2	0.727	0.117	0.020				
LDNO 132kV: Non-Domestic Aggregated or CT No Residual		0, 3, 4, 5-8	0.774	0.125	0.021	0.93			

Tariff name	Unique billing identifier	PCs	Red/black unit charge p/kWh	Amber/yellow unit charge p/kWh	Green unit charge p/kWh	Fixed charge p/MPAN/day	Capacity charge p/kVA/day	Exceeded capacity charge p/kVA/day	Reactive power charge p/kVArh
LDNO 132kV: Non-Domestic Aggregated or CT Band 1		0, 3, 4, 5-8	0.774	0.125	0.021	1.35			
LDNO 132kV: Non-Domestic Aggregated or CT Band 2		0, 3, 4, 5-8	0.774	0.125	0.021	2.01			
LDNO 132kV: Non-Domestic Aggregated or CT Band 3		0, 3, 4, 5-8	0.774	0.125	0.021	3.23			
LDNO 132kV: Non-Domestic Aggregated or CT Band 4		0, 3, 4, 5-8	0.774	0.125	0.021	7.14			
LDNO 132kV: Non-Domestic Aggregated (related MPAN)		4	0.774	0.125	0.021				
LDNO 132kV: LV Site Specific No Residual		0	0.541	0.084	0.014	0.95	0.36	0.36	0.010
LDNO 132kV: LV Site Specific Band 1		0	0.541	0.084	0.014	11.28	0.36	0.36	0.010
LDNO 132kV: LV Site Specific Band 2		0	0.541	0.084	0.014	23.09	0.36	0.36	0.010
LDNO 132kV: LV Site Specific Band 3		0	0.541	0.084	0.014	37.01	0.36	0.36	0.010
LDNO 132kV: LV Site Specific Band 4		0	0.541	0.084	0.014	95.46	0.36	0.36	0.010
LDNO 132kV: LV Sub Site Specific No Residual		0	0.530	0.072	0.013	1.64	0.58	0.58	0.009
LDNO 132kV: LV Sub Site Specific Band 1		0	0.530	0.072	0.013	19.56	0.58	0.58	0.009
LDNO 132kV: LV Sub Site Specific Band 2		0	0.530	0.072	0.013	40.04	0.58	0.58	0.009
LDNO 132kV: LV Sub Site Specific Band 3		0	0.530	0.072	0.013	64.17	0.58	0.58	0.009
LDNO 132kV: LV Sub Site Specific Band 4		0	0.530	0.072	0.013	165.51	0.58	0.58	0.009
LDNO 132kV: HV Site Specific No Residual		0	0.475	0.058	0.011	41.50	0.79	0.79	0.008
LDNO 132kV: HV Site Specific Band 1		0	0.475	0.058	0.011	225.61	0.79	0.79	0.008
LDNO 132kV: HV Site Specific Band 2		0	0.475	0.058	0.011	492.95	0.79	0.79	0.008
LDNO 132kV: HV Site Specific Band 3		0	0.475	0.058	0.011	892.78	0.79	0.79	0.008
LDNO 132kV: HV Site Specific Band 4		0	0.475	0.058	0.011	2189.65	0.79	0.79	0.008
LDNO 132kV: Unmetered Supplies		0, 1, 8	2.088	0.143	0.066				
LDNO 132kV: LV Generation Aggregated		0, 8	-0.848	-0.137	-0.023				
LDNO 132kV: LV Sub Generation Aggregated		8	-0.868	-0.137	-0.023				
LDNO 132kV: LV Generation Site Specific		0	-0.848	-0.137	-0.023				0.013
LDNO 132kV: LV Sub Generation Site Specific		0	-0.868	-0.137	-0.023				0.015
LDNO 132kV: HV Generation Site Specific		0	-0.954	-0.130	-0.023	16.29			0.024
LDNO 0000: Domestic Aggregated or CT with Residual		0, 1, 2	0.231	0.037	0.006	0.44			
LDNO 0000: Domestic Aggregated (related MPAN)		2	0.231	0.037	0.006				
LDNO 0000: Non-Domestic Aggregated or CT No Residual		0, 3, 4, 5-8	0.246	0.040	0.007	0.30			
LDNO 0000: Non-Domestic Aggregated or CT Band 1		0, 3, 4, 5-8	0.246	0.040	0.007	0.43			
LDNO 0000: Non-Domestic Aggregated or CT Band 2		0, 3, 4, 5-8	0.246	0.040	0.007	0.64			
LDNO 0000: Non-Domestic Aggregated or CT Band 3		0, 3, 4, 5-8	0.246	0.040	0.007	1.03			

Tariff name	Unique billing identifier	PCs	Red/black unit charge p/kWh	Amber/yellow unit charge p/kWh	Green unit charge p/kWh	Fixed charge p/MPAN/day	Capacity charge p/kVA/day	Exceeded capacity charge p/kVA/day	Reactive power charge p/kVArh
LDNO 0000: Non-Domestic Aggregated or CT Band 4		0, 3, 4, 5-8	0.246	0.040	0.007	2.27			
LDNO 0000: Non-Domestic Aggregated (related MPAN)		4	0.246	0.040	0.007				
LDNO 0000: LV Site Specific No Residual		0	0.172	0.027	0.005	0.30	0.11	0.11	0.003
LDNO 0000: LV Site Specific Band 1		0	0.172	0.027	0.005	3.59	0.11	0.11	0.003
LDNO 0000: LV Site Specific Band 2		0	0.172	0.027	0.005	7.35	0.11	0.11	0.003
LDNO 0000: LV Site Specific Band 3		0	0.172	0.027	0.005	11.78	0.11	0.11	0.003
LDNO 0000: LV Site Specific Band 4		0	0.172	0.027	0.005	30.37	0.11	0.11	0.003
LDNO 0000: LV Sub Site Specific No Residual		0	0.169	0.023	0.004	0.52	0.18	0.18	0.003
LDNO 0000: LV Sub Site Specific Band 1		0	0.169	0.023	0.004	6.22	0.18	0.18	0.003
LDNO 0000: LV Sub Site Specific Band 2		0	0.169	0.023	0.004	12.74	0.18	0.18	0.003
LDNO 0000: LV Sub Site Specific Band 3		0	0.169	0.023	0.004	20.42	0.18	0.18	0.003
LDNO 0000: LV Sub Site Specific Band 4		0	0.169	0.023	0.004	52.66	0.18	0.18	0.003
LDNO 0000: HV Site Specific No Residual		0	0.151	0.018	0.003	13.20	0.25	0.25	0.002
LDNO 0000: HV Site Specific Band 1		0	0.151	0.018	0.003	71.78	0.25	0.25	0.002
LDNO 0000: HV Site Specific Band 2		0	0.151	0.018	0.003	156.84	0.25	0.25	0.002
LDNO 0000: HV Site Specific Band 3		0	0.151	0.018	0.003	284.06	0.25	0.25	0.002
LDNO 0000: HV Site Specific Band 4		0	0.151	0.018	0.003	696.69	0.25	0.25	0.002
LDNO 0000: Unmetered Supplies		0, 1, 8	0.664	0.046	0.021				
LDNO 0000: LV Generation Aggregated		0, 8	-0.270	-0.044	-0.007				
LDNO 0000: LV Sub Generation Aggregated		8	-0.276	-0.044	-0.007				
LDNO 0000: LV Generation Site Specific		0	-0.270	-0.044	-0.007				0.004
LDNO 0000: LV Sub Generation Site Specific		0	-0.276	-0.044	-0.007				0.005
LDNO 0000: HV Generation Site Specific		0	-0.304	-0.041	-0.007	5.18			0.008

## Annex 4 - Charges applied to LDNOs with HV/LV end users in “SP Electricity North West Area (GSP Group \_G)”

### Southern Electric Power Distribution plc - Effective from 1st April 2027 - Final LDNO tariffs in SP Electricity North West Area (GSP Group \_G)

Time Bands for LV and HV Properties			
Time periods	Red Time Band	Amber Time Band	Green Time Band
Monday to Friday (Including Bank Holidays) All Year	16:00 to 19:00	09:00 to 16:00 19:00 to 20:30	00.00 - 09.00 20.30 - 24.00
Saturday and Sunday All Year		16:00 to 19:00	00.00 - 16.00 19.00 - 24.00
Notes	All the above times are in UK Clock time		

Time Bands for Unmetered Properties			
	Black Time Band	Yellow Time Band	Green Time Band
Monday to Friday (Including Bank Holidays) March to October Inclusive		09.00 - 20.30	00.00 - 09.00 20.30 - 24.00
Monday to Friday (Including Bank Holidays) November to February Inclusive	16:00 to 19:00	09:00 - 16.00 19.00 - 20.30	00.00 - 09.00 20.30 - 24.00
Saturday and Sunday All Year		16:00 to 19:00	00.00 - 16.00 19.00 - 24.00
Notes	All the above times are in UK Clock time		

Tariff name	Unique billing identifier	PCs	Red/black unit charge p/kWh	Amber/yellow unit charge p/kWh	Green unit charge p/kWh	Fixed charge p/MPAN/day	Capacity charge p/kVA/day	Exceeded capacity charge p/kVA/day	Reactive power charge p/kVArh
LDNO LV: Domestic Aggregated or CT with Residual		0, 1 or 2	12.164	1.851	0.102	6.01			
LDNO LV: Domestic Aggregated (related MPAN)		2	12.164	1.851	0.102				
LDNO LV: Non-Domestic Aggregated or CT No Residual		0, 3, 4 or 5-8	11.202	1.704	0.094	5.26			
LDNO LV: Non-Domestic Aggregated or CT Band 1		0, 3, 4 or 5-8	11.202	1.704	0.094	6.55			
LDNO LV: Non-Domestic Aggregated or CT Band 2		0, 3, 4 or 5-8	11.202	1.704	0.094	7.20			
LDNO LV: Non-Domestic Aggregated or CT Band 3		0, 3, 4 or 5-8	11.202	1.704	0.094	9.23			
LDNO LV: Non-Domestic Aggregated or CT Band 4		0, 3, 4 or 5-8	11.202	1.704	0.094	15.78			
LDNO LV: Non-Domestic Aggregated (related MPAN)		4	11.202	1.704	0.094				
LDNO LV: LV Site Specific No Residual		0	7.415	1.105	0.060	17.10	5.23	5.23	0.145
LDNO LV: LV Site Specific Band 1		0	7.415	1.105	0.060	39.07	5.23	5.23	0.145
LDNO LV: LV Site Specific Band 2		0	7.415	1.105	0.060	52.90	5.23	5.23	0.145
LDNO LV: LV Site Specific Band 3		0	7.415	1.105	0.060	75.29	5.23	5.23	0.145
LDNO LV: LV Site Specific Band 4		0	7.415	1.105	0.060	145.87	5.23	5.23	0.145

Tariff name	Unique billing identifier	PCs	Red/black unit charge p/kWh	Amber/yellow unit charge p/kWh	Green unit charge p/kWh	Fixed charge p/MPAN/day	Capacity charge p/kVA/day	Exceeded capacity charge p/kVA/day	Reactive power charge p/kVArh
LDNO LV: Unmetered Supplies		0, 1 or 8	34.402	3.622	2.296				
LDNO LV: LV Generation Aggregated		0 or 8	-12.646	-1.924	-0.106	0.00			
LDNO LV: LV Generation Site Specific		0 or 8	-12.646	-1.924	-0.106	0.00			0.228
LDNO HV: Domestic Aggregated or CT with Residual		0, 1 or 2	8.622	1.312	0.072	4.26			
LDNO HV: Domestic Aggregated (Related MPAN)		2	8.622	1.312	0.072				
LDNO HV: Non-Domestic Aggregated or CT No Residual		0, 3, 4 or 5-8	7.940	1.208	0.067	3.73			
LDNO HV: Non-Domestic Aggregated or CT Band 1		0, 3, 4 or 5-8	7.940	1.208	0.067	4.64			
LDNO HV: Non-Domestic Aggregated or CT Band 2		0, 3, 4 or 5-8	7.940	1.208	0.067	5.10			
LDNO HV: Non-Domestic Aggregated or CT Band 3		0, 3, 4 or 5-8	7.940	1.208	0.067	6.54			
LDNO HV: Non-Domestic Aggregated or CT Band 4		0, 3, 4 or 5-8	7.940	1.208	0.067	11.19			
LDNO HV: Non-Domestic Aggregated (related MPAN)		4	7.940	1.208	0.067				
LDNO HV: LV Site Specific No Residual		0	5.256	0.783	0.043	12.12	3.71	3.71	0.103
LDNO HV: LV Site Specific Band 1		0	5.256	0.783	0.043	27.70	3.71	3.71	0.103
LDNO HV: LV Site Specific Band 2		0	5.256	0.783	0.043	37.50	3.71	3.71	0.103
LDNO HV: LV Site Specific Band 3		0	5.256	0.783	0.043	53.36	3.71	3.71	0.103
LDNO HV: LV Site Specific Band 4		0	5.256	0.783	0.043	103.40	3.71	3.71	0.103
LDNO HV: LV Sub Site Specific No Residual		0	6.476	0.941	0.050	65.82	7.22	7.22	0.123
LDNO HV: LV Sub Site Specific Band 1		0	6.476	0.941	0.050	92.01	7.22	7.22	0.123
LDNO HV: LV Sub Site Specific Band 2		0	6.476	0.941	0.050	108.50	7.22	7.22	0.123
LDNO HV: LV Sub Site Specific Band 3		0	6.476	0.941	0.050	135.19	7.22	7.22	0.123
LDNO HV: LV Sub Site Specific Band 4		0	6.476	0.941	0.050	219.35	7.22	7.22	0.123
LDNO HV: HV Site Specific No Residual		0	5.099	0.712	0.037	171.08	8.48	8.48	0.088
LDNO HV: HV Site Specific Band 1		0	5.099	0.712	0.037	357.69	8.48	8.48	0.088
LDNO HV: HV Site Specific Band 2		0	5.099	0.712	0.037	639.58	8.48	8.48	0.088
LDNO HV: HV Site Specific Band 3		0	5.099	0.712	0.037	1113.89	8.48	8.48	0.088
LDNO HV: HV Site Specific Band 4		0	5.099	0.712	0.037	2454.33	8.48	8.48	0.088
LDNO HV: Unmetered Supplies		0, 1 or 8	24.385	2.568	1.627				
LDNO HV: LV Generation Aggregated		0 or 8	-12.646	-1.924	-0.106	0.00			
LDNO HV: LV Sub Generation Aggregated		0 or 8	-9.794	-1.466	-0.080	0.00			
LDNO HV: LV Generation Site Specific		0	-12.646	-1.924	-0.106	0.00			0.228
LDNO HV: LV Sub Generation Site Specific		0	-9.794	-1.466	-0.080	0.00			0.198
LDNO HV: HV Generation Site Specific		0	-7.196	-1.046	-0.056	0.00			0.160

Tariff name	Unique billing identifier	PCs	Red/black unit charge p/kWh	Amber/yellow unit charge p/kWh	Green unit charge p/kWh	Fixed charge p/MPAN/day	Capacity charge p/kVA/day	Exceeded capacity charge p/kVA/day	Reactive power charge p/kVArh
LDNO HVplus: Domestic Aggregated or CT with Residual		0, 1 or 2	7.042	1.071	0.059	3.54			
LDNO HVplus: Domestic Aggregated (related MPAN)		2	7.042	1.071	0.059				
LDNO HVplus: Non-Domestic Aggregated or CT No Residual		0, 3, 4 or 5-8	6.484	0.987	0.054	3.04			
LDNO HVplus: Non-Domestic Aggregated or CT Band 1		0, 3, 4 or 5-8	6.484	0.987	0.054	3.90			
LDNO HVplus: Non-Domestic Aggregated or CT Band 2		0, 3, 4 or 5-8	6.484	0.987	0.054	4.33			
LDNO HVplus: Non-Domestic Aggregated or CT Band 3		0, 3, 4 or 5-8	6.484	0.987	0.054	5.67			
LDNO HVplus: Non-Domestic Aggregated or CT Band 4		0, 3, 4 or 5-8	6.484	0.987	0.054	10.00			
LDNO HVplus: Non-Domestic Aggregated (related MPAN)		4	6.484	0.987	0.054				
LDNO HVplus: LV Site Specific No Residual		0	4.293	0.640	0.035	9.90	3.03	3.03	0.084
LDNO HVplus: LV Site Specific Band 1		0	4.293	0.640	0.035	24.42	3.03	3.03	0.084
LDNO HVplus: LV Site Specific Band 2		0	4.293	0.640	0.035	33.56	3.03	3.03	0.084
LDNO HVplus: LV Site Specific Band 3		0	4.293	0.640	0.035	48.35	3.03	3.03	0.084
LDNO HVplus: LV Site Specific Band 4		0	4.293	0.640	0.035	95.00	3.03	3.03	0.084
LDNO HVplus: LV Sub Site Specific No Residual		0	5.158	0.749	0.040	52.42	5.75	5.75	0.098
LDNO HVplus: LV Sub Site Specific Band 1		0	5.158	0.749	0.040	76.23	5.75	5.75	0.098
LDNO HVplus: LV Sub Site Specific Band 2		0	5.158	0.749	0.040	91.22	5.75	5.75	0.098
LDNO HVplus: LV Sub Site Specific Band 3		0	5.158	0.749	0.040	115.49	5.75	5.75	0.098
LDNO HVplus: LV Sub Site Specific Band 4		0	5.158	0.749	0.040	192.00	5.75	5.75	0.098
LDNO HVplus: HV Site Specific No Residual		0	4.006	0.559	0.029	134.41	6.67	6.67	0.069
LDNO HVplus: HV Site Specific Band 1		0	4.006	0.559	0.029	301.77	6.67	6.67	0.069
LDNO HVplus: HV Site Specific Band 2		0	4.006	0.559	0.029	554.57	6.67	6.67	0.069
LDNO HVplus: HV Site Specific Band 3		0	4.006	0.559	0.029	979.96	6.67	6.67	0.069
LDNO HVplus: HV Site Specific Band 4		0	4.006	0.559	0.029	2182.11	6.67	6.67	0.069
LDNO HVplus: Unmetered Supplies		0, 1 or 8	19.922	2.104	1.336				
LDNO HVplus: LV Generation Aggregated		0 or 8	-7.255	-1.104	-0.061	0.00			
LDNO HVplus: LV Sub Generation Aggregated		0 or 8	-6.553	-0.981	-0.053	0.00			
LDNO HVplus: LV Generation Site Specific		0	-7.255	-1.104	-0.061	0.00			0.131
LDNO HVplus: LV Sub Generation Site Specific		0	-6.553	-0.981	-0.053	0.00			0.132
LDNO HVplus: HV Generation Site Specific		0	-7.196	-1.046	-0.056	13.53			0.160
LDNO EHV: Domestic Aggregated or CT with Residual		0, 1 or 2	5.584	0.850	0.047	2.81			

Tariff name	Unique billing identifier	PCs	Red/black unit charge p/kWh	Amber/yellow unit charge p/kWh	Green unit charge p/kWh	Fixed charge p/MPAN/day	Capacity charge p/kVA/day	Exceeded capacity charge p/kVA/day	Reactive power charge p/kVArh
LDNO EHV: Domestic Aggregated (related MPAN)		2	5.584	0.850	0.047				
LDNO EHV: Non-Domestic Aggregated or CT No Residual		0, 3, 4 or 5-8	5.142	0.782	0.043	2.41			
LDNO EHV: Non-Domestic Aggregated or CT Band 1		0, 3, 4 or 5-8	5.142	0.782	0.043	3.09			
LDNO EHV: Non-Domestic Aggregated or CT Band 2		0, 3, 4 or 5-8	5.142	0.782	0.043	3.43			
LDNO EHV: Non-Domestic Aggregated or CT Band 3		0, 3, 4 or 5-8	5.142	0.782	0.043	4.50			
LDNO EHV: Non-Domestic Aggregated or CT Band 4		0, 3, 4 or 5-8	5.142	0.782	0.043	7.93			
LDNO EHV: Non-Domestic Aggregated (related MPAN)		4	5.142	0.782	0.043				
LDNO EHV: LV Site Specific No Residual		0	3.404	0.507	0.028	7.85	2.40	2.40	0.067
LDNO EHV: LV Site Specific Band 1		0	3.404	0.507	0.028	19.36	2.40	2.40	0.067
LDNO EHV: LV Site Specific Band 2		0	3.404	0.507	0.028	26.61	2.40	2.40	0.067
LDNO EHV: LV Site Specific Band 3		0	3.404	0.507	0.028	38.34	2.40	2.40	0.067
LDNO EHV: LV Site Specific Band 4		0	3.404	0.507	0.028	75.33	2.40	2.40	0.067
LDNO EHV: LV Sub Site Specific No Residual		0	4.090	0.594	0.032	41.56	4.56	4.56	0.078
LDNO EHV: LV Sub Site Specific Band 1		0	4.090	0.594	0.032	60.45	4.56	4.56	0.078
LDNO EHV: LV Sub Site Specific Band 2		0	4.090	0.594	0.032	72.34	4.56	4.56	0.078
LDNO EHV: LV Sub Site Specific Band 3		0	4.090	0.594	0.032	91.58	4.56	4.56	0.078
LDNO EHV: LV Sub Site Specific Band 4		0	4.090	0.594	0.032	152.25	4.56	4.56	0.078
LDNO EHV: HV Site Specific No Residual		0	3.177	0.444	0.023	106.58	5.29	5.29	0.055
LDNO EHV: HV Site Specific Band 1		0	3.177	0.444	0.023	239.29	5.29	5.29	0.055
LDNO EHV: HV Site Specific Band 2		0	3.177	0.444	0.023	439.76	5.29	5.29	0.055
LDNO EHV: HV Site Specific Band 3		0	3.177	0.444	0.023	777.08	5.29	5.29	0.055
LDNO EHV: HV Site Specific Band 4		0	3.177	0.444	0.023	1730.36	5.29	5.29	0.055
LDNO EHV: Unmetered Supplies		0, 1 or 8	15.798	1.669	1.060				
LDNO EHV: LV Generation Aggregated		0 or 8	-5.753	-0.875	-0.048	0.00			
LDNO EHV: LV Sub Generation Aggregated		0 or 8	-5.196	-0.778	-0.042	0.00			
LDNO EHV: LV Generation Site Specific		0	-5.753	-0.875	-0.048	0.00			0.104
LDNO EHV: LV Sub Generation Site Specific		0	-5.196	-0.778	-0.042	0.00			0.105
LDNO EHV: HV Generation Site Specific		0	-5.707	-0.829	-0.044	10.73			0.127
LDNO 132kV/EHV: Domestic Aggregated or CT with Residual		0, 1 or 2	4.675	0.711	0.039	2.35			
LDNO 132kV/EHV: Domestic Aggregated (related MPAN)		2	4.675	0.711	0.039				

Tariff name	Unique billing identifier	PCs	Red/black unit charge p/kWh	Amber/yellow unit charge p/kWh	Green unit charge p/kWh	Fixed charge p/MPAN/day	Capacity charge p/kVA/day	Exceeded capacity charge p/kVA/day	Reactive power charge p/kVArh
LDNO 132kV/EHV: Non-Domestic Aggregated or CT No Residual		0, 3, 4 or 5-8	4.305	0.655	0.036	2.02			
LDNO 132kV/EHV: Non-Domestic Aggregated or CT Band 1		0, 3, 4 or 5-8	4.305	0.655	0.036	2.59			
LDNO 132kV/EHV: Non-Domestic Aggregated or CT Band 2		0, 3, 4 or 5-8	4.305	0.655	0.036	2.87			
LDNO 132kV/EHV: Non-Domestic Aggregated or CT Band 3		0, 3, 4 or 5-8	4.305	0.655	0.036	3.76			
LDNO 132kV/EHV: Non-Domestic Aggregated or CT Band 4		0, 3, 4 or 5-8	4.305	0.655	0.036	6.64			
LDNO 132kV/EHV: Non-Domestic Aggregated (related MPAN)		4	4.305	0.655	0.036				
LDNO 132kV/EHV: LV Site Specific No Residual		0	2.850	0.425	0.023	6.57	2.01	2.01	0.056
LDNO 132kV/EHV: LV Site Specific Band 1		0	2.850	0.425	0.023	16.21	2.01	2.01	0.056
LDNO 132kV/EHV: LV Site Specific Band 2		0	2.850	0.425	0.023	22.28	2.01	2.01	0.056
LDNO 132kV/EHV: LV Site Specific Band 3		0	2.850	0.425	0.023	32.10	2.01	2.01	0.056
LDNO 132kV/EHV: LV Site Specific Band 4		0	2.850	0.425	0.023	63.06	2.01	2.01	0.056
LDNO 132kV/EHV: LV Sub Site Specific No Residual		0	3.424	0.498	0.026	34.80	3.82	3.82	0.065
LDNO 132kV/EHV: LV Sub Site Specific Band 1		0	3.424	0.498	0.026	50.61	3.82	3.82	0.065
LDNO 132kV/EHV: LV Sub Site Specific Band 2		0	3.424	0.498	0.026	60.56	3.82	3.82	0.065
LDNO 132kV/EHV: LV Sub Site Specific Band 3		0	3.424	0.498	0.026	76.67	3.82	3.82	0.065
LDNO 132kV/EHV: LV Sub Site Specific Band 4		0	3.424	0.498	0.026	127.46	3.82	3.82	0.065
LDNO 132kV/EHV: HV Site Specific No Residual		0	2.660	0.371	0.019	89.23	4.43	4.43	0.046
LDNO 132kV/EHV: HV Site Specific Band 1		0	2.660	0.371	0.019	200.33	4.43	4.43	0.046
LDNO 132kV/EHV: HV Site Specific Band 2		0	2.660	0.371	0.019	368.15	4.43	4.43	0.046
LDNO 132kV/EHV: HV Site Specific Band 3		0	2.660	0.371	0.019	650.55	4.43	4.43	0.046
LDNO 132kV/EHV: HV Site Specific Band 4		0	2.660	0.371	0.019	1448.60	4.43	4.43	0.046
LDNO 132kV/EHV: Unmetered Supplies		0, 1 or 8	13.225	1.397	0.887				
LDNO 132kV/EHV: LV Generation Aggregated		0 or 8	-4.816	-0.733	-0.040	0.00			
LDNO 132kV/EHV: LV Sub Generation Aggregated		0 or 8	-4.350	-0.651	-0.035	0.00			
LDNO 132kV/EHV: LV Generation Site Specific		0	-4.816	-0.733	-0.040	0.00			0.087
LDNO 132kV/EHV: LV Sub Generation Site Specific		0	-4.350	-0.651	-0.035	0.00			0.088
LDNO 132kV/EHV: HV Generation Site Specific		0	-4.777	-0.694	-0.037	8.98			0.106
LDNO 132kV: Domestic Aggregated or CT with Residual		0, 1 or 2	3.534	0.538	0.030	1.78			
LDNO 132kV: Domestic Aggregated (related MPAN)		2	3.534	0.538	0.030				

Tariff name	Unique billing identifier	PCs	Red/black unit charge p/kWh	Amber/yellow unit charge p/kWh	Green unit charge p/kWh	Fixed charge p/MPAN/day	Capacity charge p/kVA/day	Exceeded capacity charge p/kVA/day	Reactive power charge p/kVArh
LDNO 132kV: Non-Domestic Aggregated or CT No Residual		0, 3, 4 or 5-8	3.254	0.495	0.027	1.53			
LDNO 132kV: Non-Domestic Aggregated or CT Band 1		0, 3, 4 or 5-8	3.254	0.495	0.027	1.96			
LDNO 132kV: Non-Domestic Aggregated or CT Band 2		0, 3, 4 or 5-8	3.254	0.495	0.027	2.17			
LDNO 132kV: Non-Domestic Aggregated or CT Band 3		0, 3, 4 or 5-8	3.254	0.495	0.027	2.84			
LDNO 132kV: Non-Domestic Aggregated or CT Band 4		0, 3, 4 or 5-8	3.254	0.495	0.027	5.02			
LDNO 132kV: Non-Domestic Aggregated (related MPAN)		4	3.254	0.495	0.027				
LDNO 132kV: LV Site Specific No Residual		0	2.154	0.321	0.017	4.97	1.52	1.52	0.042
LDNO 132kV: LV Site Specific Band 1		0	2.154	0.321	0.017	12.26	1.52	1.52	0.042
LDNO 132kV: LV Site Specific Band 2		0	2.154	0.321	0.017	16.84	1.52	1.52	0.042
LDNO 132kV: LV Site Specific Band 3		0	2.154	0.321	0.017	24.27	1.52	1.52	0.042
LDNO 132kV: LV Site Specific Band 4		0	2.154	0.321	0.017	47.68	1.52	1.52	0.042
LDNO 132kV: LV Sub Site Specific No Residual		0	2.589	0.376	0.020	26.31	2.89	2.89	0.049
LDNO 132kV: LV Sub Site Specific Band 1		0	2.589	0.376	0.020	38.26	2.89	2.89	0.049
LDNO 132kV: LV Sub Site Specific Band 2		0	2.589	0.376	0.020	45.78	2.89	2.89	0.049
LDNO 132kV: LV Sub Site Specific Band 3		0	2.589	0.376	0.020	57.96	2.89	2.89	0.049
LDNO 132kV: LV Sub Site Specific Band 4		0	2.589	0.376	0.020	96.36	2.89	2.89	0.049
LDNO 132kV: HV Site Specific No Residual		0	2.011	0.281	0.014	67.46	3.35	3.35	0.035
LDNO 132kV: HV Site Specific Band 1		0	2.011	0.281	0.014	151.45	3.35	3.35	0.035
LDNO 132kV: HV Site Specific Band 2		0	2.011	0.281	0.014	278.33	3.35	3.35	0.035
LDNO 132kV: HV Site Specific Band 3		0	2.011	0.281	0.014	491.82	3.35	3.35	0.035
LDNO 132kV: HV Site Specific Band 4		0	2.011	0.281	0.014	1095.15	3.35	3.35	0.035
LDNO 132kV: Unmetered Supplies		0, 1 or 8	9.999	1.056	0.671				
LDNO 132kV: LV Generation Aggregated		0 or 8	-3.641	-0.554	-0.031	0.00			
LDNO 132kV: LV Sub Generation Aggregated		0 or 8	-3.289	-0.492	-0.027	0.00			
LDNO 132kV: LV Generation Site Specific		0	-3.641	-0.554	-0.031	0.00			0.066
LDNO 132kV: LV Sub Generation Site Specific		0	-3.289	-0.492	-0.027	0.00			0.066
LDNO 132kV: HV Generation Site Specific		0	-3.612	-0.525	-0.028	6.79			0.080
LDNO 0000: Domestic Aggregated or CT with Residual		0, 1 or 2	1.294	0.197	0.011	0.65			
LDNO 0000: Domestic Aggregated (related MPAN)		2	1.294	0.197	0.011				
LDNO 0000: Non-Domestic Aggregated or CT No Residual		0, 3, 4 or 5-8	1.192	0.181	0.010	0.56			
LDNO 0000: Non-Domestic Aggregated or CT Band 1		0, 3, 4 or 5-8	1.192	0.181	0.010	0.72			

Tariff name	Unique billing identifier	PCs	Red/black unit charge p/kWh	Amber/yellow unit charge p/kWh	Green unit charge p/kWh	Fixed charge p/MPAN/day	Capacity charge p/kVA/day	Exceeded capacity charge p/kVA/day	Reactive power charge p/kVArh
LDNO 0000: Non-Domestic Aggregated or CT Band 2		0, 3, 4 or 5-8	1.192	0.181	0.010	0.80			
LDNO 0000: Non-Domestic Aggregated or CT Band 3		0, 3, 4 or 5-8	1.192	0.181	0.010	1.04			
LDNO 0000: Non-Domestic Aggregated or CT Band 4		0, 3, 4 or 5-8	1.192	0.181	0.010	1.84			
LDNO 0000: Non-Domestic Aggregated (related MPAN)		4	1.192	0.181	0.010				
LDNO 0000: LV Site Specific No Residual		0	0.789	0.118	0.006	1.82	0.56	0.56	0.015
LDNO 0000: LV Site Specific Band 1		0	0.789	0.118	0.006	4.49	0.56	0.56	0.015
LDNO 0000: LV Site Specific Band 2		0	0.789	0.118	0.006	6.17	0.56	0.56	0.015
LDNO 0000: LV Site Specific Band 3		0	0.789	0.118	0.006	8.89	0.56	0.56	0.015
LDNO 0000: LV Site Specific Band 4		0	0.789	0.118	0.006	17.46	0.56	0.56	0.015
LDNO 0000: LV Sub Site Specific No Residual		0	0.948	0.138	0.007	9.63	1.06	1.06	0.018
LDNO 0000: LV Sub Site Specific Band 1		0	0.948	0.138	0.007	14.01	1.06	1.06	0.018
LDNO 0000: LV Sub Site Specific Band 2		0	0.948	0.138	0.007	16.76	1.06	1.06	0.018
LDNO 0000: LV Sub Site Specific Band 3		0	0.948	0.138	0.007	21.22	1.06	1.06	0.018
LDNO 0000: LV Sub Site Specific Band 4		0	0.948	0.138	0.007	35.28	1.06	1.06	0.018
LDNO 0000: HV Site Specific No Residual		0	0.736	0.103	0.005	24.70	1.22	1.22	0.013
LDNO 0000: HV Site Specific Band 1		0	0.736	0.103	0.005	55.46	1.22	1.22	0.013
LDNO 0000: HV Site Specific Band 2		0	0.736	0.103	0.005	101.91	1.22	1.22	0.013
LDNO 0000: HV Site Specific Band 3		0	0.736	0.103	0.005	180.09	1.22	1.22	0.013
LDNO 0000: HV Site Specific Band 4		0	0.736	0.103	0.005	401.01	1.22	1.22	0.013
LDNO 0000: Unmetered Supplies		0, 1 or 8	3.661	0.387	0.246				
LDNO 0000: LV Generation Aggregated		0 or 8	-1.333	-0.203	-0.011	0.00			
LDNO 0000: LV Sub Generation Aggregated		0 or 8	-1.204	-0.180	-0.010	0.00			
LDNO 0000: LV Generation Site Specific		0	-1.333	-0.203	-0.011	0.00			0.024
LDNO 0000: LV Sub Generation Site Specific		0	-1.204	-0.180	-0.010	0.00			0.024
LDNO 0000: HV Generation Site Specific		0	-1.323	-0.192	-0.010	2.49			0.029

## Annex 4 - Charges applied to LDNOs with HV/LV end users in “South Eastern Power Networks Area (GSP Group \_J)”

### Southern Electric Power Distribution plc - Effective from 1st April 2027 - Final LDNO tariffs in UKPN SPN Area (GSP Group \_J)

Time Bands for LV and HV Properties			
Time periods	Red Time Band	Amber Time Band	Green Time Band
Monday to Friday (Including Bank Holidays) All Year	16:00 - 19:00	07:00 - 16:00 19:00 - 23:00	00:00 - 07:00 23:00 - 24:00
Saturday and Sunday All Year			00:00 - 24:00
Notes	All times are in UK Clock time		

Time Bands for Unmetered Properties			
	Black Time Band	Yellow Time Band	Green Time Band
Monday to Friday (Including Bank Holidays) November to February Inclusive	16:00 - 19:00	07:00 - 16:00 19:00 - 23:00	00:00 - 07:00 23:00 - 24:00
Monday to Friday (Including Bank Holidays) March to October Inclusive		07:00 - 23:00	00:00 - 07:00 23:00 - 24:00
Saturday and Sunday All Year			00:00 - 24:00
Notes	All times are in UK Clock time		

Tariff name	Unique billing identifier	PCs	Red/black unit charge p/kWh	Amber/yellow unit charge p/kWh	Green unit charge p/kWh	Fixed charge p/MPAN/day	Capacity charge p/kVA/day	Exceeded capacity charge p/kVA/day	Reactive power charge p/kVArh
LDNO LV: Domestic Aggregated or CT with Residual		0, 1, 2	13.726	0.627	0.215	8.92			
LDNO LV: Domestic Aggregated (related MPAN)		2	13.726	0.627	0.215				
LDNO LV: Non-Domestic Aggregated or CT No Residual		0, 3, 4, 5-8	10.941	0.500	0.171	6.20			
LDNO LV: Non-Domestic Aggregated or CT Band 1		0, 3, 4, 5-8	10.941	0.500	0.171	8.88			
LDNO LV: Non-Domestic Aggregated or CT Band 2		0, 3, 4, 5-8	10.941	0.500	0.171	13.97			
LDNO LV: Non-Domestic Aggregated or CT Band 3		0, 3, 4, 5-8	10.941	0.500	0.171	21.88			
LDNO LV: Non-Domestic Aggregated or CT Band 4		0, 3, 4, 5-8	10.941	0.500	0.171	49.47			
LDNO LV: Non-Domestic Aggregated (related MPAN)		4	10.941	0.500	0.171				
LDNO LV: LV Site Specific No Residual		0	8.116	0.347	0.121	14.41	5.96	5.96	0.271
LDNO LV: LV Site Specific Band 1		0	8.116	0.347	0.121	119.28	5.96	5.96	0.271
LDNO LV: LV Site Specific Band 2		0	8.116	0.347	0.121	197.10	5.96	5.96	0.271
LDNO LV: LV Site Specific Band 3		0	8.116	0.347	0.121	283.85	5.96	5.96	0.271
LDNO LV: LV Site Specific Band 4		0	8.116	0.347	0.121	628.95	5.96	5.96	0.271

Tariff name	Unique billing identifier	PCs	Red/black unit charge p/kWh	Amber/yellow unit charge p/kWh	Green unit charge p/kWh	Fixed charge p/MPAN/day	Capacity charge p/kVA/day	Exceeded capacity charge p/kVA/day	Reactive power charge p/kVArh
LDNO LV: Unmetered Supplies		0, 1 or 8	38.362	2.164	1.755				
LDNO LV: LV Generation Aggregated		0, 8	-13.185	-0.602	-0.206	0.00			
LDNO LV: LV Generation Site Specific		0	-13.185	-0.602	-0.206	0.00			0.464
LDNO HV: Domestic Aggregated or CT with Residual		0, 1, 2	10.578	0.483	0.166	6.87			
LDNO HV: Domestic Aggregated (Related MPAN)		2	10.578	0.483	0.166				
LDNO HV: Non-Domestic Aggregated or CT No Residual		0, 3, 4, 5-8	8.432	0.385	0.132	4.78			
LDNO HV: Non-Domestic Aggregated or CT Band 1		0, 3, 4, 5-8	8.432	0.385	0.132	6.84			
LDNO HV: Non-Domestic Aggregated or CT Band 2		0, 3, 4, 5-8	8.432	0.385	0.132	10.76			
LDNO HV: Non-Domestic Aggregated or CT Band 3		0, 3, 4, 5-8	8.432	0.385	0.132	16.86			
LDNO HV: Non-Domestic Aggregated or CT Band 4		0, 3, 4, 5-8	8.432	0.385	0.132	38.13			
LDNO HV: Non-Domestic Aggregated (related MPAN)		4	8.432	0.385	0.132				
LDNO HV: LV Site Specific No Residual		0	6.255	0.267	0.093	11.11	4.60	4.60	0.209
LDNO HV: LV Site Specific Band 1		0	6.255	0.267	0.093	91.92	4.60	4.60	0.209
LDNO HV: LV Site Specific Band 2		0	6.255	0.267	0.093	151.89	4.60	4.60	0.209
LDNO HV: LV Site Specific Band 3		0	6.255	0.267	0.093	218.75	4.60	4.60	0.209
LDNO HV: LV Site Specific Band 4		0	6.255	0.267	0.093	484.69	4.60	4.60	0.209
LDNO HV: LV Sub Site Specific No Residual		0	6.347	0.238	0.086	14.83	6.04	6.04	0.202
LDNO HV: LV Sub Site Specific Band 1		0	6.347	0.238	0.086	143.03	6.04	6.04	0.202
LDNO HV: LV Sub Site Specific Band 2		0	6.347	0.238	0.086	238.17	6.04	6.04	0.202
LDNO HV: LV Sub Site Specific Band 3		0	6.347	0.238	0.086	344.23	6.04	6.04	0.202
LDNO HV: LV Sub Site Specific Band 4		0	6.347	0.238	0.086	766.11	6.04	6.04	0.202
LDNO HV: HV Site Specific No Residual		0	5.784	0.200	0.074	175.18	6.06	6.06	0.185
LDNO HV: HV Site Specific Band 1		0	5.784	0.200	0.074	1250.23	6.06	6.06	0.185
LDNO HV: HV Site Specific Band 2		0	5.784	0.200	0.074	2904.48	6.06	6.06	0.185
LDNO HV: HV Site Specific Band 3		0	5.784	0.200	0.074	3718.67	6.06	6.06	0.185
LDNO HV: HV Site Specific Band 4		0	5.784	0.200	0.074	10609.68	6.06	6.06	0.185
LDNO HV: Unmetered Supplies		0, 1 or 8	29.563	1.668	1.353				
LDNO HV: LV Generation Aggregated		0, 8	-13.185	-0.602	-0.206	0.00			
LDNO HV: LV Sub Generation Aggregated		0	-10.608	-0.463	-0.161	0.00			
LDNO HV: LV Generation Site Specific		0	-13.185	-0.602	-0.206	0.00			0.464
LDNO HV: LV Sub Generation Site Specific		0	-10.608	-0.463	-0.161	0.00			0.348
LDNO HV: HV Generation Site Specific		0	-7.474	-0.280	-0.101	0.00			0.302

Tariff name	Unique billing identifier	PCs	Red/black unit charge p/kWh	Amber/yellow unit charge p/kWh	Green unit charge p/kWh	Fixed charge p/MPAN/day	Capacity charge p/kVA/day	Exceeded capacity charge p/kVA/day	Reactive power charge p/kVArh
LDNO HVplus: Domestic Aggregated or CT with Residual		0, 1, 2	7.747	0.354	0.121	5.03			
LDNO HVplus: Domestic Aggregated (related MPAN)		2	7.747	0.354	0.121				
LDNO HVplus: Non-Domestic Aggregated or CT No Residual		0, 3, 4, 5-8	6.175	0.282	0.097	3.50			
LDNO HVplus: Non-Domestic Aggregated or CT Band 1		0, 3, 4, 5-8	6.175	0.282	0.097	5.01			
LDNO HVplus: Non-Domestic Aggregated or CT Band 2		0, 3, 4, 5-8	6.175	0.282	0.097	7.88			
LDNO HVplus: Non-Domestic Aggregated or CT Band 3		0, 3, 4, 5-8	6.175	0.282	0.097	12.35			
LDNO HVplus: Non-Domestic Aggregated or CT Band 4		0, 3, 4, 5-8	6.175	0.282	0.097	27.92			
LDNO HVplus: Non-Domestic Aggregated (related MPAN)		4	6.175	0.282	0.097				
LDNO HVplus: LV Site Specific No Residual		0	4.581	0.196	0.068	8.14	3.37	3.37	0.153
LDNO HVplus: LV Site Specific Band 1		0	4.581	0.196	0.068	67.32	3.37	3.37	0.153
LDNO HVplus: LV Site Specific Band 2		0	4.581	0.196	0.068	111.25	3.37	3.37	0.153
LDNO HVplus: LV Site Specific Band 3		0	4.581	0.196	0.068	160.21	3.37	3.37	0.153
LDNO HVplus: LV Site Specific Band 4		0	4.581	0.196	0.068	354.99	3.37	3.37	0.153
LDNO HVplus: LV Sub Site Specific No Residual		0	4.587	0.172	0.062	10.72	4.36	4.36	0.146
LDNO HVplus: LV Sub Site Specific Band 1		0	4.587	0.172	0.062	103.37	4.36	4.36	0.146
LDNO HVplus: LV Sub Site Specific Band 2		0	4.587	0.172	0.062	172.13	4.36	4.36	0.146
LDNO HVplus: LV Sub Site Specific Band 3		0	4.587	0.172	0.062	248.78	4.36	4.36	0.146
LDNO HVplus: LV Sub Site Specific Band 4		0	4.587	0.172	0.062	553.68	4.36	4.36	0.146
LDNO HVplus: HV Site Specific No Residual		0	4.160	0.144	0.054	125.99	4.36	4.36	0.133
LDNO HVplus: HV Site Specific Band 1		0	4.160	0.144	0.054	899.15	4.36	4.36	0.133
LDNO HVplus: HV Site Specific Band 2		0	4.160	0.144	0.054	2088.87	4.36	4.36	0.133
LDNO HVplus: HV Site Specific Band 3		0	4.160	0.144	0.054	2674.42	4.36	4.36	0.133
LDNO HVplus: HV Site Specific Band 4		0	4.160	0.144	0.054	7630.36	4.36	4.36	0.133
LDNO HVplus: Unmetered Supplies		0, 1 or 8	21.652	1.221	0.991				
LDNO HVplus: LV Generation Aggregated		0, 8	-7.450	-0.340	-0.117	0.00			
LDNO HVplus: LV Sub Generation Aggregated		0	-6.646	-0.290	-0.101	0.00			
LDNO HVplus: LV Generation Site Specific		0	-7.450	-0.340	-0.117	0.00			0.262
LDNO HVplus: LV Sub Generation Site Specific		0	-6.646	-0.290	-0.101	0.00			0.218
LDNO HVplus: HV Generation Site Specific		0	-7.474	-0.280	-0.101	14.11			0.302
LDNO EHV: Domestic Aggregated or CT with Residual		0, 1, 2	6.258	0.286	0.098	4.07			
LDNO EHV: Domestic Aggregated (related MPAN)		2	6.258	0.286	0.098				

Tariff name	Unique billing identifier	PCs	Red/black unit charge p/kWh	Amber/yellow unit charge p/kWh	Green unit charge p/kWh	Fixed charge p/MPAN/day	Capacity charge p/kVA/day	Exceeded capacity charge p/kVA/day	Reactive power charge p/kVArh
LDNO EHV: Non-Domestic Aggregated or CT No Residual		0, 3, 4, 5-8	4.988	0.228	0.078	2.83			
LDNO EHV: Non-Domestic Aggregated or CT Band 1		0, 3, 4, 5-8	4.988	0.228	0.078	4.05			
LDNO EHV: Non-Domestic Aggregated or CT Band 2		0, 3, 4, 5-8	4.988	0.228	0.078	6.37			
LDNO EHV: Non-Domestic Aggregated or CT Band 3		0, 3, 4, 5-8	4.988	0.228	0.078	9.98			
LDNO EHV: Non-Domestic Aggregated or CT Band 4		0, 3, 4, 5-8	4.988	0.228	0.078	22.56			
LDNO EHV: Non-Domestic Aggregated (related MPAN)		4	4.988	0.228	0.078				
LDNO EHV: LV Site Specific No Residual		0	3.700	0.158	0.055	6.57	2.72	2.72	0.124
LDNO EHV: LV Site Specific Band 1		0	3.700	0.158	0.055	54.38	2.72	2.72	0.124
LDNO EHV: LV Site Specific Band 2		0	3.700	0.158	0.055	89.87	2.72	2.72	0.124
LDNO EHV: LV Site Specific Band 3		0	3.700	0.158	0.055	129.42	2.72	2.72	0.124
LDNO EHV: LV Site Specific Band 4		0	3.700	0.158	0.055	286.76	2.72	2.72	0.124
LDNO EHV: LV Sub Site Specific No Residual		0	3.705	0.139	0.050	8.66	3.52	3.52	0.118
LDNO EHV: LV Sub Site Specific Band 1		0	3.705	0.139	0.050	83.50	3.52	3.52	0.118
LDNO EHV: LV Sub Site Specific Band 2		0	3.705	0.139	0.050	139.04	3.52	3.52	0.118
LDNO EHV: LV Sub Site Specific Band 3		0	3.705	0.139	0.050	200.96	3.52	3.52	0.118
LDNO EHV: LV Sub Site Specific Band 4		0	3.705	0.139	0.050	447.26	3.52	3.52	0.118
LDNO EHV: HV Site Specific No Residual		0	3.360	0.116	0.043	101.77	3.52	3.52	0.108
LDNO EHV: HV Site Specific Band 1		0	3.360	0.116	0.043	726.33	3.52	3.52	0.108
LDNO EHV: HV Site Specific Band 2		0	3.360	0.116	0.043	1687.38	3.52	3.52	0.108
LDNO EHV: HV Site Specific Band 3		0	3.360	0.116	0.043	2160.39	3.52	3.52	0.108
LDNO EHV: HV Site Specific Band 4		0	3.360	0.116	0.043	6163.78	3.52	3.52	0.108
LDNO EHV: Unmetered Supplies		0, 1 or 8	17.491	0.987	0.800				
LDNO EHV: LV Generation Aggregated		0, 8	-6.018	-0.275	-0.094	0.00			
LDNO EHV: LV Sub Generation Aggregated		0	-5.369	-0.234	-0.081	0.00			
LDNO EHV: LV Generation Site Specific		0	-6.018	-0.275	-0.094	0.00			0.212
LDNO EHV: LV Sub Generation Site Specific		0	-5.369	-0.234	-0.081	0.00			0.176
LDNO EHV: HV Generation Site Specific		0	-6.037	-0.226	-0.082	11.40			0.244
LDNO 132kV/EHV: Domestic Aggregated or CT with Residual		0, 1, 2	5.205	0.238	0.081	3.38			
LDNO 132kV/EHV: Domestic Aggregated (related MPAN)		2	5.205	0.238	0.081				
LDNO 132kV/EHV: Non-Domestic Aggregated or CT No Residual		0, 3, 4, 5-8	4.149	0.189	0.065	2.35			

Tariff name	Unique billing identifier	PCs	Red/black unit charge p/kWh	Amber/yellow unit charge p/kWh	Green unit charge p/kWh	Fixed charge p/MPAN/day	Capacity charge p/kVA/day	Exceeded capacity charge p/kVA/day	Reactive power charge p/kVArh
LDNO 132kV/EHV: Non-Domestic Aggregated or CT Band 1		0, 3, 4, 5-8	4.149	0.189	0.065	3.37			
LDNO 132kV/EHV: Non-Domestic Aggregated or CT Band 2		0, 3, 4, 5-8	4.149	0.189	0.065	5.30			
LDNO 132kV/EHV: Non-Domestic Aggregated or CT Band 3		0, 3, 4, 5-8	4.149	0.189	0.065	8.30			
LDNO 132kV/EHV: Non-Domestic Aggregated or CT Band 4		0, 3, 4, 5-8	4.149	0.189	0.065	18.76			
LDNO 132kV/EHV: Non-Domestic Aggregated (related MPAN)		4	4.149	0.189	0.065				
LDNO 132kV/EHV: LV Site Specific No Residual		0	3.077	0.131	0.046	5.47	2.26	2.26	0.103
LDNO 132kV/EHV: LV Site Specific Band 1		0	3.077	0.131	0.046	45.23	2.26	2.26	0.103
LDNO 132kV/EHV: LV Site Specific Band 2		0	3.077	0.131	0.046	74.74	2.26	2.26	0.103
LDNO 132kV/EHV: LV Site Specific Band 3		0	3.077	0.131	0.046	107.63	2.26	2.26	0.103
LDNO 132kV/EHV: LV Site Specific Band 4		0	3.077	0.131	0.046	238.48	2.26	2.26	0.103
LDNO 132kV/EHV: LV Sub Site Specific No Residual		0	3.081	0.116	0.042	7.20	2.93	2.93	0.098
LDNO 132kV/EHV: LV Sub Site Specific Band 1		0	3.081	0.116	0.042	69.44	2.93	2.93	0.098
LDNO 132kV/EHV: LV Sub Site Specific Band 2		0	3.081	0.116	0.042	115.64	2.93	2.93	0.098
LDNO 132kV/EHV: LV Sub Site Specific Band 3		0	3.081	0.116	0.042	167.13	2.93	2.93	0.098
LDNO 132kV/EHV: LV Sub Site Specific Band 4		0	3.081	0.116	0.042	371.96	2.93	2.93	0.098
LDNO 132kV/EHV: HV Site Specific No Residual		0	2.795	0.096	0.036	84.64	2.93	2.93	0.089
LDNO 132kV/EHV: HV Site Specific Band 1		0	2.795	0.096	0.036	604.04	2.93	2.93	0.089
LDNO 132kV/EHV: HV Site Specific Band 2		0	2.795	0.096	0.036	1403.30	2.93	2.93	0.089
LDNO 132kV/EHV: HV Site Specific Band 3		0	2.795	0.096	0.036	1796.67	2.93	2.93	0.089
LDNO 132kV/EHV: HV Site Specific Band 4		0	2.795	0.096	0.036	5126.05	2.93	2.93	0.089
LDNO 132kV/EHV: Unmetered Supplies		0, 1 or 8	14.546	0.821	0.666				
LDNO 132kV/EHV: LV Generation Aggregated		0, 8	-5.005	-0.229	-0.078	0.00			
LDNO 132kV/EHV: LV Sub Generation Aggregated		0	-4.465	-0.195	-0.068	0.00			
LDNO 132kV/EHV: LV Generation Site Specific		0	-5.005	-0.229	-0.078	0.00			0.176
LDNO 132kV/EHV: LV Sub Generation Site Specific		0	-4.465	-0.195	-0.068	0.00			0.146
LDNO 132kV/EHV: HV Generation Site Specific		0	-5.021	-0.188	-0.068	9.48			0.203
LDNO 132kV: Domestic Aggregated or CT with Residual		0, 1, 2	3.654	0.167	0.057	2.37			
LDNO 132kV: Domestic Aggregated (related MPAN)		2	3.654	0.167	0.057				
LDNO 132kV: Non-Domestic Aggregated or CT No Residual		0, 3, 4, 5-8	2.912	0.133	0.046	1.65			

Tariff name	Unique billing identifier	PCs	Red/black unit charge p/kWh	Amber/yellow unit charge p/kWh	Green unit charge p/kWh	Fixed charge p/MPAN/day	Capacity charge p/kVA/day	Exceeded capacity charge p/kVA/day	Reactive power charge p/kVArh
LDNO 132kV: Non-Domestic Aggregated or CT Band 1		0, 3, 4, 5-8	2.912	0.133	0.046	2.36			
LDNO 132kV: Non-Domestic Aggregated or CT Band 2		0, 3, 4, 5-8	2.912	0.133	0.046	3.72			
LDNO 132kV: Non-Domestic Aggregated or CT Band 3		0, 3, 4, 5-8	2.912	0.133	0.046	5.82			
LDNO 132kV: Non-Domestic Aggregated or CT Band 4		0, 3, 4, 5-8	2.912	0.133	0.046	13.17			
LDNO 132kV: Non-Domestic Aggregated (related MPAN)		4	2.912	0.133	0.046				
LDNO 132kV: LV Site Specific No Residual		0	2.160	0.092	0.032	3.84	1.59	1.59	0.072
LDNO 132kV: LV Site Specific Band 1		0	2.160	0.092	0.032	31.75	1.59	1.59	0.072
LDNO 132kV: LV Site Specific Band 2		0	2.160	0.092	0.032	52.46	1.59	1.59	0.072
LDNO 132kV: LV Site Specific Band 3		0	2.160	0.092	0.032	75.56	1.59	1.59	0.072
LDNO 132kV: LV Site Specific Band 4		0	2.160	0.092	0.032	167.41	1.59	1.59	0.072
LDNO 132kV: LV Sub Site Specific No Residual		0	2.163	0.081	0.029	5.05	2.06	2.06	0.069
LDNO 132kV: LV Sub Site Specific Band 1		0	2.163	0.081	0.029	48.75	2.06	2.06	0.069
LDNO 132kV: LV Sub Site Specific Band 2		0	2.163	0.081	0.029	81.18	2.06	2.06	0.069
LDNO 132kV: LV Sub Site Specific Band 3		0	2.163	0.081	0.029	117.32	2.06	2.06	0.069
LDNO 132kV: LV Sub Site Specific Band 4		0	2.163	0.081	0.029	261.12	2.06	2.06	0.069
LDNO 132kV: HV Site Specific No Residual		0	1.962	0.068	0.025	59.42	2.06	2.06	0.063
LDNO 132kV: HV Site Specific Band 1		0	1.962	0.068	0.025	424.04	2.06	2.06	0.063
LDNO 132kV: HV Site Specific Band 2		0	1.962	0.068	0.025	985.11	2.06	2.06	0.063
LDNO 132kV: HV Site Specific Band 3		0	1.962	0.068	0.025	1261.26	2.06	2.06	0.063
LDNO 132kV: HV Site Specific Band 4		0	1.962	0.068	0.025	3598.48	2.06	2.06	0.063
LDNO 132kV: Unmetered Supplies		0, 1 or 8	10.211	0.576	0.467				
LDNO 132kV: LV Generation Aggregated		0, 8	-3.514	-0.160	-0.055	0.00			
LDNO 132kV: LV Sub Generation Aggregated		0	-3.134	-0.137	-0.047	0.00			
LDNO 132kV: LV Generation Site Specific		0	-3.514	-0.160	-0.055	0.00			0.124
LDNO 132kV: LV Sub Generation Site Specific		0	-3.134	-0.137	-0.047	0.00			0.103
LDNO 132kV: HV Generation Site Specific		0	-3.525	-0.132	-0.048	6.66			0.142
LDNO 0000: Domestic Aggregated or CT with Residual		0, 1, 2	1.240	0.057	0.019	0.81			
LDNO 0000: Domestic Aggregated (related MPAN)		2	1.240	0.057	0.019				
LDNO 0000: Non-Domestic Aggregated or CT No Residual		0, 3, 4, 5-8	0.989	0.045	0.015	0.56			
LDNO 0000: Non-Domestic Aggregated or CT Band 1		0, 3, 4, 5-8	0.989	0.045	0.015	0.80			
LDNO 0000: Non-Domestic Aggregated or CT Band 2		0, 3, 4, 5-8	0.989	0.045	0.015	1.26			
LDNO 0000: Non-Domestic Aggregated or CT Band 3		0, 3, 4, 5-8	0.989	0.045	0.015	1.98			

Tariff name	Unique billing identifier	PCs	Red/black unit charge p/kWh	Amber/yellow unit charge p/kWh	Green unit charge p/kWh	Fixed charge p/MPAN/day	Capacity charge p/kVA/day	Exceeded capacity charge p/kVA/day	Reactive power charge p/kVArh
LDNO 0000: Non-Domestic Aggregated or CT Band 4		0, 3, 4, 5-8	0.989	0.045	0.015	4.47			
LDNO 0000: Non-Domestic Aggregated (related MPAN)		4	0.989	0.045	0.015				
LDNO 0000: LV Site Specific No Residual		0	0.733	0.031	0.011	1.30	0.54	0.54	0.024
LDNO 0000: LV Site Specific Band 1		0	0.733	0.031	0.011	10.78	0.54	0.54	0.024
LDNO 0000: LV Site Specific Band 2		0	0.733	0.031	0.011	17.81	0.54	0.54	0.024
LDNO 0000: LV Site Specific Band 3		0	0.733	0.031	0.011	25.65	0.54	0.54	0.024
LDNO 0000: LV Site Specific Band 4		0	0.733	0.031	0.011	56.83	0.54	0.54	0.024
LDNO 0000: LV Sub Site Specific No Residual		0	0.734	0.028	0.010	1.72	0.70	0.70	0.023
LDNO 0000: LV Sub Site Specific Band 1		0	0.734	0.028	0.010	16.55	0.70	0.70	0.023
LDNO 0000: LV Sub Site Specific Band 2		0	0.734	0.028	0.010	27.55	0.70	0.70	0.023
LDNO 0000: LV Sub Site Specific Band 3		0	0.734	0.028	0.010	39.82	0.70	0.70	0.023
LDNO 0000: LV Sub Site Specific Band 4		0	0.734	0.028	0.010	88.63	0.70	0.70	0.023
LDNO 0000: HV Site Specific No Residual		0	0.666	0.023	0.009	20.17	0.70	0.70	0.021
LDNO 0000: HV Site Specific Band 1		0	0.666	0.023	0.009	143.94	0.70	0.70	0.021
LDNO 0000: HV Site Specific Band 2		0	0.666	0.023	0.009	334.39	0.70	0.70	0.021
LDNO 0000: HV Site Specific Band 3		0	0.666	0.023	0.009	428.13	0.70	0.70	0.021
LDNO 0000: HV Site Specific Band 4		0	0.666	0.023	0.009	1221.48	0.70	0.70	0.021
LDNO 0000: Unmetered Supplies		0, 1 or 8	3.466	0.196	0.159				
LDNO 0000: LV Generation Aggregated		0, 8	-1.193	-0.054	-0.019	0.00			
LDNO 0000: LV Sub Generation Aggregated		0	-1.064	-0.046	-0.016	0.00			
LDNO 0000: LV Generation Site Specific		0	-1.193	-0.054	-0.019	0.00			0.042
LDNO 0000: LV Sub Generation Site Specific		0	-1.064	-0.046	-0.016	0.00			0.035
LDNO 0000: HV Generation Site Specific		0	-1.196	-0.045	-0.016	2.26			0.048

## Annex 4 - Charges applied to LDNOs with HV/LV end users in “NGED South Wales Area (GSP Group \_K)”

### Southern Electric Power Distribution plc - Effective from 1st April 2027 - Final LDNO tariffs in NGED South Wales Area (GSP Group \_K)

Time Bands for LV and HV Properties			
Time periods	Red Time Band	Amber Time Band	Green Time Band
Monday to Friday (Including Bank Holidays) All Year	17:00 to 19:30	07:30 to 17:00 19:30 to 22:00	00:00 to 07:30 22:00 to 24:00
Saturday and Sunday All Year		12:00 to 13:00 16:00 to 21:00	00:00 to 12:00 13:00 to 16:00 21:00 to 24:00
Notes	All the above times are in UK Clock time		

Time Bands for Unmetered Properties			
	Black Time Band	Yellow Time Band	Green Time Band
Monday to Friday (Including Bank Holidays) Nov to Feb Inclusive (excluding 22nd Dec to 4th Jan inclusive)	17:00 to 19:30	07:30 to 17:00 19:30 to 22:00	00:00 to 07:30 22:00 to 24:00
Monday to Friday (Including Bank Holidays) Mar to Oct Inclusive (plus 22nd Dec to 4th Jan inclusive)		07:30 to 22:00	00:00 to 07:30 22:00 to 24:00
Saturday and Sunday All Year		12:00 to 13:00 16:00 to 21:00	00:00 to 12:00 13:00 to 16:00 21:00 to 24:00
Notes	All the above times are in UK Clock time		

Tariff name	Unique billing identifier	PCs	Red/black unit charge p/kWh	Amber/yellow unit charge p/kWh	Green unit charge p/kWh	Fixed charge p/MPAN/day	Capacity charge p/kVA/day	Exceeded capacity charge p/kVA/day	Reactive power charge p/kVArh
LDNO LV: Domestic Aggregated or CT with Residual		0, 1, 2	12.165	1.122	0.218	10.30			
LDNO LV: Domestic Aggregated (related MPAN)		2	12.165	1.122	0.218				
LDNO LV: Non-Domestic Aggregated or CT No Residual		0, 3, 4, 5-8	12.591	1.162	0.226	10.37			
LDNO LV: Non-Domestic Aggregated or CT Band 1		0, 3, 4, 5-8	12.591	1.162	0.226	14.27			
LDNO LV: Non-Domestic Aggregated or CT Band 2		0, 3, 4, 5-8	12.591	1.162	0.226	21.17			
LDNO LV: Non-Domestic Aggregated or CT Band 3		0, 3, 4, 5-8	12.591	1.162	0.226	33.10			
LDNO LV: Non-Domestic Aggregated or CT Band 4		0, 3, 4, 5-8	12.591	1.162	0.226	68.99			
LDNO LV: Non-Domestic Aggregated (related MPAN)		4	12.591	1.162	0.226				
LDNO LV: LV Site Specific No Residual		0	8.093	0.705	0.147	11.82	7.02	7.02	0.196
LDNO LV: LV Site Specific Band 1		0	8.093	0.705	0.147	113.44	7.02	7.02	0.196

Tariff name	Unique billing identifier	PCs	Red/black unit charge p/kWh	Amber/yellow unit charge p/kWh	Green unit charge p/kWh	Fixed charge p/MPAN/day	Capacity charge p/kVA/day	Exceeded capacity charge p/kVA/day	Reactive power charge p/kVArh
LDNO LV: LV Site Specific Band 2		0	8.093	0.705	0.147	207.45	7.02	7.02	0.196
LDNO LV: LV Site Specific Band 3		0	8.093	0.705	0.147	342.01	7.02	7.02	0.196
LDNO LV: LV Site Specific Band 4		0	8.093	0.705	0.147	788.77	7.02	7.02	0.196
LDNO LV: Unmetered Supplies		0, 1 or 8	39.787	2.427	1.490				
LDNO LV: LV Generation Aggregated		0	-12.614	-1.164	-0.226	0.00			
LDNO LV: LV Generation Site Specific		0	-12.614	-1.164	-0.226	0.00			0.376
LDNO HV: Domestic Aggregated or CT with Residual		0, 1, 2	7.468	0.689	0.134	6.32			
LDNO HV: Domestic Aggregated (Related MPAN)		2	7.468	0.689	0.134				
LDNO HV: Non-Domestic Aggregated or CT No Residual		0, 3, 4, 5-8	7.729	0.713	0.139	6.37			
LDNO HV: Non-Domestic Aggregated or CT Band 1		0, 3, 4, 5-8	7.729	0.713	0.139	8.76			
LDNO HV: Non-Domestic Aggregated or CT Band 2		0, 3, 4, 5-8	7.729	0.713	0.139	13.00			
LDNO HV: Non-Domestic Aggregated or CT Band 3		0, 3, 4, 5-8	7.729	0.713	0.139	20.32			
LDNO HV: Non-Domestic Aggregated or CT Band 4		0, 3, 4, 5-8	7.729	0.713	0.139	42.35			
LDNO HV: Non-Domestic Aggregated (related MPAN)		4	7.729	0.713	0.139				
LDNO HV: LV Site Specific No Residual		0	4.968	0.433	0.091	7.25	4.31	4.31	0.120
LDNO HV: LV Site Specific Band 1		0	4.968	0.433	0.091	69.64	4.31	4.31	0.120
LDNO HV: LV Site Specific Band 2		0	4.968	0.433	0.091	127.34	4.31	4.31	0.120
LDNO HV: LV Site Specific Band 3		0	4.968	0.433	0.091	209.95	4.31	4.31	0.120
LDNO HV: LV Site Specific Band 4		0	4.968	0.433	0.091	484.20	4.31	4.31	0.120
LDNO HV: LV Sub Site Specific No Residual		0	5.246	0.385	0.100	9.21	6.58	6.58	0.119
LDNO HV: LV Sub Site Specific Band 1		0	5.246	0.385	0.100	110.74	6.58	6.58	0.119
LDNO HV: LV Sub Site Specific Band 2		0	5.246	0.385	0.100	204.65	6.58	6.58	0.119
LDNO HV: LV Sub Site Specific Band 3		0	5.246	0.385	0.100	339.08	6.58	6.58	0.119
LDNO HV: LV Sub Site Specific Band 4		0	5.246	0.385	0.100	785.40	6.58	6.58	0.119
LDNO HV: HV Site Specific No Residual		0	4.216	0.282	0.079	102.86	8.23	8.23	0.091
LDNO HV: HV Site Specific Band 1		0	4.216	0.282	0.079	973.36	8.23	8.23	0.091
LDNO HV: HV Site Specific Band 2		0	4.216	0.282	0.079	2371.02	8.23	8.23	0.091
LDNO HV: HV Site Specific Band 3		0	4.216	0.282	0.079	4344.90	8.23	8.23	0.091
LDNO HV: HV Site Specific Band 4		0	4.216	0.282	0.079	10035.52	8.23	8.23	0.091
LDNO HV: Unmetered Supplies		0, 1 or 8	24.424	1.490	0.914				
LDNO HV: LV Generation Aggregated		0	-12.614	-1.164	-0.226	0.00			
LDNO HV: LV Sub Generation Aggregated		0	-10.955	-0.978	-0.198	0.00			
LDNO HV: LV Generation Site Specific		0	-12.614	-1.164	-0.226	0.00			0.376

Tariff name	Unique billing identifier	PCs	Red/black unit charge p/kWh	Amber/yellow unit charge p/kWh	Green unit charge p/kWh	Fixed charge p/MPAN/day	Capacity charge p/kVA/day	Exceeded capacity charge p/kVA/day	Reactive power charge p/kVArh
LDNO HV: LV Sub Generation Site Specific		0	-10.955	-0.978	-0.198	0.00			0.281
LDNO HV: HV Generation Site Specific		0	-6.536	-0.479	-0.124	0.00			0.239

Tariff name	Unique billing identifier	PCs	Red/black unit charge p/kWh	Amber/yellow unit charge p/kWh	Green unit charge p/kWh	Fixed charge p/MPAN/day	Capacity charge p/kVA/day	Exceeded capacity charge p/kVA/day	Reactive power charge p/kVArh
LDNO HVplus: Domestic Aggregated or CT with Residual		0, 1, 2	4.698	0.433	0.084	3.98			
LDNO HVplus: Domestic Aggregated (related MPAN)		2	4.698	0.433	0.084				
LDNO HVplus: Non-Domestic Aggregated or CT No Residual		0, 3, 4, 5-8	4.862	0.449	0.087	4.01			
LDNO HVplus: Non-Domestic Aggregated or CT Band 1		0, 3, 4, 5-8	4.862	0.449	0.087	5.51			
LDNO HVplus: Non-Domestic Aggregated or CT Band 2		0, 3, 4, 5-8	4.862	0.449	0.087	8.18			
LDNO HVplus: Non-Domestic Aggregated or CT Band 3		0, 3, 4, 5-8	4.862	0.449	0.087	12.78			
LDNO HVplus: Non-Domestic Aggregated or CT Band 4		0, 3, 4, 5-8	4.862	0.449	0.087	26.64			
LDNO HVplus: Non-Domestic Aggregated (related MPAN)		4	4.862	0.449	0.087				
LDNO HVplus: LV Site Specific No Residual		0	3.125	0.272	0.057	4.56	2.71	2.71	0.076
LDNO HVplus: LV Site Specific Band 1		0	3.125	0.272	0.057	43.81	2.71	2.71	0.076
LDNO HVplus: LV Site Specific Band 2		0	3.125	0.272	0.057	80.11	2.71	2.71	0.076
LDNO HVplus: LV Site Specific Band 3		0	3.125	0.272	0.057	132.07	2.71	2.71	0.076
LDNO HVplus: LV Site Specific Band 4		0	3.125	0.272	0.057	304.60	2.71	2.71	0.076
LDNO HVplus: LV Sub Site Specific No Residual		0	3.215	0.236	0.061	5.65	4.03	4.03	0.073
LDNO HVplus: LV Sub Site Specific Band 1		0	3.215	0.236	0.061	67.87	4.03	4.03	0.073
LDNO HVplus: LV Sub Site Specific Band 2		0	3.215	0.236	0.061	125.43	4.03	4.03	0.073
LDNO HVplus: LV Sub Site Specific Band 3		0	3.215	0.236	0.061	207.81	4.03	4.03	0.073
LDNO HVplus: LV Sub Site Specific Band 4		0	3.215	0.236	0.061	481.35	4.03	4.03	0.073
LDNO HVplus: HV Site Specific No Residual		0	2.536	0.170	0.048	61.86	4.95	4.95	0.055
LDNO HVplus: HV Site Specific Band 1		0	2.536	0.170	0.048	585.39	4.95	4.95	0.055
LDNO HVplus: HV Site Specific Band 2		0	2.536	0.170	0.048	1425.95	4.95	4.95	0.055
LDNO HVplus: HV Site Specific Band 3		0	2.536	0.170	0.048	2613.06	4.95	4.95	0.055
LDNO HVplus: HV Site Specific Band 4		0	2.536	0.170	0.048	6035.45	4.95	4.95	0.055
LDNO HVplus: Unmetered Supplies		0, 1 or 8	15.364	0.937	0.575				
LDNO HVplus: LV Generation Aggregated		0	-4.900	-0.452	-0.088	0.00			

Tariff name	Unique billing identifier	PCs	Red/black unit charge p/kWh	Amber/yellow unit charge p/kWh	Green unit charge p/kWh	Fixed charge p/MPAN/day	Capacity charge p/kVA/day	Exceeded capacity charge p/kVA/day	Reactive power charge p/kVArh
LDNO HVplus: LV Sub Generation Aggregated		0	-5.050	-0.451	-0.091	0.00			
LDNO HVplus: LV Generation Site Specific		0	-4.900	-0.452	-0.088	0.00			0.146
LDNO HVplus: LV Sub Generation Site Specific		0	-5.050	-0.451	-0.091	0.00			0.129
LDNO HVplus: HV Generation Site Specific		0	-6.536	-0.479	-0.124	83.99			0.239
LDNO EHV: Domestic Aggregated or CT with Residual		0, 1, 2	3.750	0.346	0.067	3.17			
LDNO EHV: Domestic Aggregated (related MPAN)		2	3.750	0.346	0.067				
LDNO EHV: Non-Domestic Aggregated or CT No Residual		0, 3, 4, 5-8	3.881	0.358	0.070	3.20			
LDNO EHV: Non-Domestic Aggregated or CT Band 1		0, 3, 4, 5-8	3.881	0.358	0.070	4.40			
LDNO EHV: Non-Domestic Aggregated or CT Band 2		0, 3, 4, 5-8	3.881	0.358	0.070	6.53			
LDNO EHV: Non-Domestic Aggregated or CT Band 3		0, 3, 4, 5-8	3.881	0.358	0.070	10.20			
LDNO EHV: Non-Domestic Aggregated or CT Band 4		0, 3, 4, 5-8	3.881	0.358	0.070	21.27			
LDNO EHV: Non-Domestic Aggregated (related MPAN)		4	3.881	0.358	0.070				
LDNO EHV: LV Site Specific No Residual		0	2.495	0.217	0.045	3.64	2.16	2.16	0.060
LDNO EHV: LV Site Specific Band 1		0	2.495	0.217	0.045	34.97	2.16	2.16	0.060
LDNO EHV: LV Site Specific Band 2		0	2.495	0.217	0.045	63.95	2.16	2.16	0.060
LDNO EHV: LV Site Specific Band 3		0	2.495	0.217	0.045	105.43	2.16	2.16	0.060
LDNO EHV: LV Site Specific Band 4		0	2.495	0.217	0.045	243.14	2.16	2.16	0.060
LDNO EHV: LV Sub Site Specific No Residual		0	2.567	0.188	0.049	4.51	3.22	3.22	0.058
LDNO EHV: LV Sub Site Specific Band 1		0	2.567	0.188	0.049	54.18	3.22	3.22	0.058
LDNO EHV: LV Sub Site Specific Band 2		0	2.567	0.188	0.049	100.12	3.22	3.22	0.058
LDNO EHV: LV Sub Site Specific Band 3		0	2.567	0.188	0.049	165.89	3.22	3.22	0.058
LDNO EHV: LV Sub Site Specific Band 4		0	2.567	0.188	0.049	384.23	3.22	3.22	0.058
LDNO EHV: HV Site Specific No Residual		0	2.024	0.136	0.038	49.38	3.95	3.95	0.044
LDNO EHV: HV Site Specific Band 1		0	2.024	0.136	0.038	467.28	3.95	3.95	0.044
LDNO EHV: HV Site Specific Band 2		0	2.024	0.136	0.038	1138.25	3.95	3.95	0.044
LDNO EHV: HV Site Specific Band 3		0	2.024	0.136	0.038	2085.85	3.95	3.95	0.044
LDNO EHV: HV Site Specific Band 4		0	2.024	0.136	0.038	4817.74	3.95	3.95	0.044
LDNO EHV: Unmetered Supplies		0, 1 or 8	12.264	0.748	0.459				
LDNO EHV: LV Generation Aggregated		0	-3.912	-0.361	-0.070	0.00			
LDNO EHV: LV Sub Generation Aggregated		0	-4.031	-0.360	-0.073	0.00			
LDNO EHV: LV Generation Site Specific		0	-3.912	-0.361	-0.070	0.00			0.116
LDNO EHV: LV Sub Generation Site Specific		0	-4.031	-0.360	-0.073	0.00			0.103
LDNO EHV: HV Generation Site Specific		0	-5.217	-0.382	-0.099	67.04			0.191

Tariff name	Unique billing identifier	PCs	Red/black unit charge p/kWh	Amber/yellow unit charge p/kWh	Green unit charge p/kWh	Fixed charge p/MPAN/day	Capacity charge p/kVA/day	Exceeded capacity charge p/kVA/day	Reactive power charge p/kVArh
LDNO 132kV/EHV: Domestic Aggregated or CT with Residual		0, 1, 2	3.145	0.290	0.056	2.66			
LDNO 132kV/EHV: Domestic Aggregated (related MPAN)		2	3.145	0.290	0.056				
LDNO 132kV/EHV: Non-Domestic Aggregated or CT No Residual		0, 3, 4, 5-8	3.255	0.300	0.058	2.68			
LDNO 132kV/EHV: Non-Domestic Aggregated or CT Band 1		0, 3, 4, 5-8	3.255	0.300	0.058	3.69			
LDNO 132kV/EHV: Non-Domestic Aggregated or CT Band 2		0, 3, 4, 5-8	3.255	0.300	0.058	5.47			
LDNO 132kV/EHV: Non-Domestic Aggregated or CT Band 3		0, 3, 4, 5-8	3.255	0.300	0.058	8.56			
LDNO 132kV/EHV: Non-Domestic Aggregated or CT Band 4		0, 3, 4, 5-8	3.255	0.300	0.058	17.84			
LDNO 132kV/EHV: Non-Domestic Aggregated (related MPAN)		4	3.255	0.300	0.058				
LDNO 132kV/EHV: LV Site Specific No Residual		0	2.092	0.182	0.038	3.05	1.81	1.81	0.051
LDNO 132kV/EHV: LV Site Specific Band 1		0	2.092	0.182	0.038	29.33	1.81	1.81	0.051
LDNO 132kV/EHV: LV Site Specific Band 2		0	2.092	0.182	0.038	53.63	1.81	1.81	0.051
LDNO 132kV/EHV: LV Site Specific Band 3		0	2.092	0.182	0.038	88.42	1.81	1.81	0.051
LDNO 132kV/EHV: LV Site Specific Band 4		0	2.092	0.182	0.038	203.92	1.81	1.81	0.051
LDNO 132kV/EHV: LV Sub Site Specific No Residual		0	2.153	0.158	0.041	3.78	2.70	2.70	0.049
LDNO 132kV/EHV: LV Sub Site Specific Band 1		0	2.153	0.158	0.041	45.44	2.70	2.70	0.049
LDNO 132kV/EHV: LV Sub Site Specific Band 2		0	2.153	0.158	0.041	83.97	2.70	2.70	0.049
LDNO 132kV/EHV: LV Sub Site Specific Band 3		0	2.153	0.158	0.041	139.13	2.70	2.70	0.049
LDNO 132kV/EHV: LV Sub Site Specific Band 4		0	2.153	0.158	0.041	322.26	2.70	2.70	0.049
LDNO 132kV/EHV: HV Site Specific No Residual		0	1.698	0.114	0.032	41.41	3.32	3.32	0.037
LDNO 132kV/EHV: HV Site Specific Band 1		0	1.698	0.114	0.032	391.91	3.32	3.32	0.037
LDNO 132kV/EHV: HV Site Specific Band 2		0	1.698	0.114	0.032	954.66	3.32	3.32	0.037
LDNO 132kV/EHV: HV Site Specific Band 3		0	1.698	0.114	0.032	1749.42	3.32	3.32	0.037
LDNO 132kV/EHV: HV Site Specific Band 4		0	1.698	0.114	0.032	4040.67	3.32	3.32	0.037
LDNO 132kV/EHV: Unmetered Supplies		0, 1 or 8	10.286	0.627	0.385				
LDNO 132kV/EHV: LV Generation Aggregated		0	-3.281	-0.303	-0.059	0.00			
LDNO 132kV/EHV: LV Sub Generation Aggregated		0	-3.381	-0.302	-0.061	0.00			
LDNO 132kV/EHV: LV Generation Site Specific		0	-3.281	-0.303	-0.059	0.00			0.098
LDNO 132kV/EHV: LV Sub Generation Site Specific		0	-3.381	-0.302	-0.061	0.00			0.087

Tariff name	Unique billing identifier	PCs	Red/black unit charge p/kWh	Amber/yellow unit charge p/kWh	Green unit charge p/kWh	Fixed charge p/MPAN/day	Capacity charge p/kVA/day	Exceeded capacity charge p/kVA/day	Reactive power charge p/kVArh
LDNO 132kV/EHV: HV Generation Site Specific		0	-4.375	-0.321	-0.083	56.23			0.160
LDNO 132kV: Domestic Aggregated or CT with Residual		0, 1, 2	1.786	0.165	0.032	1.51			
LDNO 132kV: Domestic Aggregated (related MPAN)		2	1.786	0.165	0.032				
LDNO 132kV: Non-Domestic Aggregated or CT No Residual		0, 3, 4, 5-8	1.849	0.171	0.033	1.52			
LDNO 132kV: Non-Domestic Aggregated or CT Band 1		0, 3, 4, 5-8	1.849	0.171	0.033	2.10			
LDNO 132kV: Non-Domestic Aggregated or CT Band 2		0, 3, 4, 5-8	1.849	0.171	0.033	3.11			
LDNO 132kV: Non-Domestic Aggregated or CT Band 3		0, 3, 4, 5-8	1.849	0.171	0.033	4.86			
LDNO 132kV: Non-Domestic Aggregated or CT Band 4		0, 3, 4, 5-8	1.849	0.171	0.033	10.13			
LDNO 132kV: Non-Domestic Aggregated (related MPAN)		4	1.849	0.171	0.033				
LDNO 132kV: LV Site Specific No Residual		0	1.188	0.104	0.022	1.74	1.03	1.03	0.029
LDNO 132kV: LV Site Specific Band 1		0	1.188	0.104	0.022	16.66	1.03	1.03	0.029
LDNO 132kV: LV Site Specific Band 2		0	1.188	0.104	0.022	30.46	1.03	1.03	0.029
LDNO 132kV: LV Site Specific Band 3		0	1.188	0.104	0.022	50.22	1.03	1.03	0.029
LDNO 132kV: LV Site Specific Band 4		0	1.188	0.104	0.022	115.82	1.03	1.03	0.029
LDNO 132kV: LV Sub Site Specific No Residual		0	1.223	0.090	0.023	2.15	1.53	1.53	0.028
LDNO 132kV: LV Sub Site Specific Band 1		0	1.223	0.090	0.023	25.81	1.53	1.53	0.028
LDNO 132kV: LV Sub Site Specific Band 2		0	1.223	0.090	0.023	47.69	1.53	1.53	0.028
LDNO 132kV: LV Sub Site Specific Band 3		0	1.223	0.090	0.023	79.02	1.53	1.53	0.028
LDNO 132kV: LV Sub Site Specific Band 4		0	1.223	0.090	0.023	183.03	1.53	1.53	0.028
LDNO 132kV: HV Site Specific No Residual		0	0.964	0.065	0.018	23.52	1.88	1.88	0.021
LDNO 132kV: HV Site Specific Band 1		0	0.964	0.065	0.018	222.59	1.88	1.88	0.021
LDNO 132kV: HV Site Specific Band 2		0	0.964	0.065	0.018	542.20	1.88	1.88	0.021
LDNO 132kV: HV Site Specific Band 3		0	0.964	0.065	0.018	993.59	1.88	1.88	0.021
LDNO 132kV: HV Site Specific Band 4		0	0.964	0.065	0.018	2294.92	1.88	1.88	0.021
LDNO 132kV: Unmetered Supplies		0, 1 or 8	5.842	0.356	0.219				
LDNO 132kV: LV Generation Aggregated		0	-1.863	-0.172	-0.033	0.00			
LDNO 132kV: LV Sub Generation Aggregated		0	-1.920	-0.171	-0.035	0.00			
LDNO 132kV: LV Generation Site Specific		0	-1.863	-0.172	-0.033	0.00			0.055
LDNO 132kV: LV Sub Generation Site Specific		0	-1.920	-0.171	-0.035	0.00			0.049
LDNO 132kV: HV Generation Site Specific		0	-2.485	-0.182	-0.047	31.94			0.091
LDNO 0000: Domestic Aggregated or CT with Residual		0, 1, 2	0.532	0.049	0.010	0.45			
LDNO 0000: Domestic Aggregated (related MPAN)		2	0.532	0.049	0.010				

Tariff name	Unique billing identifier	PCs	Red/black unit charge p/kWh	Amber/yellow unit charge p/kWh	Green unit charge p/kWh	Fixed charge p/MPAN/day	Capacity charge p/kVA/day	Exceeded capacity charge p/kVA/day	Reactive power charge p/kVArh
LDNO 0000: Non-Domestic Aggregated or CT No Residual		0, 3, 4, 5-8	0.550	0.051	0.010	0.45			
LDNO 0000: Non-Domestic Aggregated or CT Band 1		0, 3, 4, 5-8	0.550	0.051	0.010	0.62			
LDNO 0000: Non-Domestic Aggregated or CT Band 2		0, 3, 4, 5-8	0.550	0.051	0.010	0.93			
LDNO 0000: Non-Domestic Aggregated or CT Band 3		0, 3, 4, 5-8	0.550	0.051	0.010	1.45			
LDNO 0000: Non-Domestic Aggregated or CT Band 4		0, 3, 4, 5-8	0.550	0.051	0.010	3.01			
LDNO 0000: Non-Domestic Aggregated (related MPAN)		4	0.550	0.051	0.010				
LDNO 0000: LV Site Specific No Residual		0	0.354	0.031	0.006	0.52	0.31	0.31	0.009
LDNO 0000: LV Site Specific Band 1		0	0.354	0.031	0.006	4.96	0.31	0.31	0.009
LDNO 0000: LV Site Specific Band 2		0	0.354	0.031	0.006	9.06	0.31	0.31	0.009
LDNO 0000: LV Site Specific Band 3		0	0.354	0.031	0.006	14.94	0.31	0.31	0.009
LDNO 0000: LV Site Specific Band 4		0	0.354	0.031	0.006	34.47	0.31	0.31	0.009
LDNO 0000: LV Sub Site Specific No Residual		0	0.364	0.027	0.007	0.64	0.46	0.46	0.008
LDNO 0000: LV Sub Site Specific Band 1		0	0.364	0.027	0.007	7.68	0.46	0.46	0.008
LDNO 0000: LV Sub Site Specific Band 2		0	0.364	0.027	0.007	14.19	0.46	0.46	0.008
LDNO 0000: LV Sub Site Specific Band 3		0	0.364	0.027	0.007	23.52	0.46	0.46	0.008
LDNO 0000: LV Sub Site Specific Band 4		0	0.364	0.027	0.007	54.47	0.46	0.46	0.008
LDNO 0000: HV Site Specific No Residual		0	0.287	0.019	0.005	7.00	0.56	0.56	0.006
LDNO 0000: HV Site Specific Band 1		0	0.287	0.019	0.005	66.24	0.56	0.56	0.006
LDNO 0000: HV Site Specific Band 2		0	0.287	0.019	0.005	161.35	0.56	0.56	0.006
LDNO 0000: HV Site Specific Band 3		0	0.287	0.019	0.005	295.68	0.56	0.56	0.006
LDNO 0000: HV Site Specific Band 4		0	0.287	0.019	0.005	682.95	0.56	0.56	0.006
LDNO 0000: Unmetered Supplies		0, 1 or 8	1.739	0.106	0.065				
LDNO 0000: LV Generation Aggregated		0	-0.555	-0.051	-0.010	0.00			
LDNO 0000: LV Sub Generation Aggregated		0	-0.571	-0.051	-0.010	0.00			
LDNO 0000: LV Generation Site Specific		0	-0.555	-0.051	-0.010	0.00			0.017
LDNO 0000: LV Sub Generation Site Specific		0	-0.571	-0.051	-0.010	0.00			0.015
LDNO 0000: HV Generation Site Specific		0	-0.740	-0.054	-0.014	9.50			0.027

## Annex 4 - Charges applied to LDNOs with HV/LV end users in “NGED South West Area (GSP Group \_L)”

### Southern Electric Power Distribution plc - Effective from 1st April 2027 - Final LDNO tariffs in NGED South West Area (GSP Group \_L)

Time Bands for LV and HV Properties			
Time periods	Red Time Band	Amber Time Band	Green Time Band
Monday to Friday (Including Bank Holidays) All Year	17.00 - 19.00	07:30 to 17:00 19:00 to 21:30	00:00 to 07:30 21:30 to 24:00
Saturday and Sunday All Year		16:30 to 19:30	00:00 to 16:30 19:30 to 24:00
Notes	All the above times are in UK Clock time		

Time Bands for Unmetered Properties			
	Black Time Band	Yellow Time Band	Green Time Band
Monday to Friday (Including Bank Holidays) Nov to Feb Inclusive (excluding 22nd Dec to 4th Jan inclusive)	17:00 to 19:00	07:30 to 17:00 19:00 to 21:30	00:00 to 07:30 21:30 to 24:00
Monday to Friday (Including Bank Holidays) Mar to Oct Inclusive (plus 22nd Dec to 4th Jan inclusive)		07:30 to 21:30	00:00 to 07:30 21:30 to 24:00
Saturday and Sunday All Year		16:30 to 19:30	00:00 to 16:30 19:30 to 24:00
Notes	All the above times are in UK Clock time		

Tariff name	Unique billing identifier	PCs	Red/black unit charge p/kWh	Amber/yellow unit charge p/kWh	Green unit charge p/kWh	Fixed charge p/MPAN/day	Capacity charge p/kVA/day	Exceeded capacity charge p/kVA/day	Reactive power charge p/kVArh
LDNO LV: Domestic Aggregated or CT with Residual		1, 2 or 0	15.081	1.203	0.119	10.59			
LDNO LV: Domestic Aggregated (related MPAN)		2	15.081	1.203	0.119				
LDNO LV: Non-Domestic Aggregated or CT No Residual		3 to 8 or 0	14.754	1.177	0.116	11.43			
LDNO LV: Non-Domestic Aggregated or CT Band 1		3 to 8 or 0	14.754	1.177	0.116	13.38			
LDNO LV: Non-Domestic Aggregated or CT Band 2		3 to 8 or 0	14.754	1.177	0.116	19.36			
LDNO LV: Non-Domestic Aggregated or CT Band 3		3 to 8 or 0	14.754	1.177	0.116	27.36			
LDNO LV: Non-Domestic Aggregated or CT Band 4		3 to 8 or 0	14.754	1.177	0.116	50.14			
LDNO LV: Non-Domestic Aggregated (related MPAN)		4	14.754	1.177	0.116				
LDNO LV: LV Site Specific No Residual		0	9.162	0.651	0.066	11.33	7.67	7.67	0.150
LDNO LV: LV Site Specific Band 1		0	9.162	0.651	0.066	84.51	7.67	7.67	0.150

Tariff name	Unique billing identifier	PCs	Red/black unit charge p/kWh	Amber/yellow unit charge p/kWh	Green unit charge p/kWh	Fixed charge p/MPAN/day	Capacity charge p/kVA/day	Exceeded capacity charge p/kVA/day	Reactive power charge p/kVArh
LDNO LV: LV Site Specific Band 2		0	9.162	0.651	0.066	142.66	7.67	7.67	0.150
LDNO LV: LV Site Specific Band 3		0	9.162	0.651	0.066	220.07	7.67	7.67	0.150
LDNO LV: LV Site Specific Band 4		0	9.162	0.651	0.066	473.87	7.67	7.67	0.150
LDNO LV: Unmetered Supplies		0, 1 or 8	45.018	2.464	1.224				
LDNO LV: LV Generation Aggregated		0	-15.280	-1.219	-0.121	0.00			
LDNO LV: LV Generation Site Specific		0	-15.280	-1.219	-0.121	0.00			0.312
LDNO HV: Domestic Aggregated or CT with Residual		1, 2 or 0	10.108	0.806	0.080	7.10			
LDNO HV: Domestic Aggregated (Related MPAN)		2	10.108	0.806	0.080				
LDNO HV: Non-Domestic Aggregated or CT No Residual		3 to 8 or 0	9.889	0.789	0.078	7.66			
LDNO HV: Non-Domestic Aggregated or CT Band 1		3 to 8 or 0	9.889	0.789	0.078	8.97			
LDNO HV: Non-Domestic Aggregated or CT Band 2		3 to 8 or 0	9.889	0.789	0.078	12.97			
LDNO HV: Non-Domestic Aggregated or CT Band 3		3 to 8 or 0	9.889	0.789	0.078	18.34			
LDNO HV: Non-Domestic Aggregated or CT Band 4		3 to 8 or 0	9.889	0.789	0.078	33.61			
LDNO HV: Non-Domestic Aggregated (related MPAN)		4	9.889	0.789	0.078				
LDNO HV: LV Site Specific No Residual		0	6.142	0.437	0.044	7.60	5.14	5.14	0.101
LDNO HV: LV Site Specific Band 1		0	6.142	0.437	0.044	56.65	5.14	5.14	0.101
LDNO HV: LV Site Specific Band 2		0	6.142	0.437	0.044	95.62	5.14	5.14	0.101
LDNO HV: LV Site Specific Band 3		0	6.142	0.437	0.044	147.51	5.14	5.14	0.101
LDNO HV: LV Site Specific Band 4		0	6.142	0.437	0.044	317.64	5.14	5.14	0.101
LDNO HV: LV Sub Site Specific No Residual		0	6.776	0.342	0.037	10.28	7.63	7.63	0.096
LDNO HV: LV Sub Site Specific Band 1		0	6.776	0.342	0.037	95.30	7.63	7.63	0.096
LDNO HV: LV Sub Site Specific Band 2		0	6.776	0.342	0.037	162.86	7.63	7.63	0.096
LDNO HV: LV Sub Site Specific Band 3		0	6.776	0.342	0.037	252.81	7.63	7.63	0.096
LDNO HV: LV Sub Site Specific Band 4		0	6.776	0.342	0.037	547.71	7.63	7.63	0.096
LDNO HV: HV Site Specific No Residual		0	6.148	0.236	0.027	112.73	8.70	8.70	0.079
LDNO HV: HV Site Specific Band 1		0	6.148	0.236	0.027	848.40	8.70	8.70	0.079
LDNO HV: HV Site Specific Band 2		0	6.148	0.236	0.027	1810.11	8.70	8.70	0.079
LDNO HV: HV Site Specific Band 3		0	6.148	0.236	0.027	3952.13	8.70	8.70	0.079
LDNO HV: HV Site Specific Band 4		0	6.148	0.236	0.027	7507.68	8.70	8.70	0.079
LDNO HV: Unmetered Supplies		0, 1 or 8	30.175	1.652	0.821				
LDNO HV: LV Generation Aggregated		0	-15.280	-1.219	-0.121	0.00			
LDNO HV: LV Sub Generation Aggregated		0	-13.109	-0.975	-0.097	0.00			
LDNO HV: LV Generation Site Specific		0	-15.280	-1.219	-0.121	0.00			0.312

Tariff name	Unique billing identifier	PCs	Red/black unit charge p/kWh	Amber/yellow unit charge p/kWh	Green unit charge p/kWh	Fixed charge p/MPAN/day	Capacity charge p/kVA/day	Exceeded capacity charge p/kVA/day	Reactive power charge p/kVArh
LDNO HV: LV Sub Generation Site Specific		0	-13.109	-0.975	-0.097	0.00			0.224
LDNO HV: HV Generation Site Specific		0	-8.196	-0.414	-0.045	0.00			0.187

Tariff name	Unique billing identifier	PCs	Red/black unit charge p/kWh	Amber/yellow unit charge p/kWh	Green unit charge p/kWh	Fixed charge p/MPAN/day	Capacity charge p/kVA/day	Exceeded capacity charge p/kVA/day	Reactive power charge p/kVArh
LDNO HVplus: Domestic Aggregated or CT with Residual		1, 2 or 0	7.086	0.565	0.056	4.98			
LDNO HVplus: Domestic Aggregated (related MPAN)		2	7.086	0.565	0.056				
LDNO HVplus: Non-Domestic Aggregated or CT No Residual		3 to 8 or 0	6.932	0.553	0.055	5.37			
LDNO HVplus: Non-Domestic Aggregated or CT Band 1		3 to 8 or 0	6.932	0.553	0.055	6.29			
LDNO HVplus: Non-Domestic Aggregated or CT Band 2		3 to 8 or 0	6.932	0.553	0.055	9.09			
LDNO HVplus: Non-Domestic Aggregated or CT Band 3		3 to 8 or 0	6.932	0.553	0.055	12.86			
LDNO HVplus: Non-Domestic Aggregated or CT Band 4		3 to 8 or 0	6.932	0.553	0.055	23.56			
LDNO HVplus: Non-Domestic Aggregated (related MPAN)		4	6.932	0.553	0.055				
LDNO HVplus: LV Site Specific No Residual		0	4.305	0.306	0.031	5.33	3.60	3.60	0.070
LDNO HVplus: LV Site Specific Band 1		0	4.305	0.306	0.031	39.71	3.60	3.60	0.070
LDNO HVplus: LV Site Specific Band 2		0	4.305	0.306	0.031	67.03	3.60	3.60	0.070
LDNO HVplus: LV Site Specific Band 3		0	4.305	0.306	0.031	103.41	3.60	3.60	0.070
LDNO HVplus: LV Site Specific Band 4		0	4.305	0.306	0.031	222.66	3.60	3.60	0.070
LDNO HVplus: LV Sub Site Specific No Residual		0	4.640	0.234	0.025	7.04	5.22	5.22	0.065
LDNO HVplus: LV Sub Site Specific Band 1		0	4.640	0.234	0.025	65.25	5.22	5.22	0.065
LDNO HVplus: LV Sub Site Specific Band 2		0	4.640	0.234	0.025	111.51	5.22	5.22	0.065
LDNO HVplus: LV Sub Site Specific Band 3		0	4.640	0.234	0.025	173.10	5.22	5.22	0.065
LDNO HVplus: LV Sub Site Specific Band 4		0	4.640	0.234	0.025	375.01	5.22	5.22	0.065
LDNO HVplus: HV Site Specific No Residual		0	4.160	0.159	0.018	76.28	5.89	5.89	0.054
LDNO HVplus: HV Site Specific Band 1		0	4.160	0.159	0.018	574.08	5.89	5.89	0.054
LDNO HVplus: HV Site Specific Band 2		0	4.160	0.159	0.018	1224.84	5.89	5.89	0.054
LDNO HVplus: HV Site Specific Band 3		0	4.160	0.159	0.018	2674.27	5.89	5.89	0.054
LDNO HVplus: HV Site Specific Band 4		0	4.160	0.159	0.018	5080.18	5.89	5.89	0.054
LDNO HVplus: Unmetered Supplies		0, 1 or 8	21.153	1.158	0.575				
LDNO HVplus: LV Generation Aggregated		0	-7.219	-0.576	-0.057	0.00			

Tariff name	Unique billing identifier	PCs	Red/black unit charge p/kWh	Amber/yellow unit charge p/kWh	Green unit charge p/kWh	Fixed charge p/MPAN/day	Capacity charge p/kVA/day	Exceeded capacity charge p/kVA/day	Reactive power charge p/kVArh
LDNO HVplus: LV Sub Generation Aggregated		0	-7.271	-0.541	-0.054	0.00			
LDNO HVplus: LV Generation Site Specific		0	-7.219	-0.576	-0.057	0.00			0.148
LDNO HVplus: LV Sub Generation Site Specific		0	-7.271	-0.541	-0.054	0.00			0.124
LDNO HVplus: HV Generation Site Specific		0	-8.196	-0.414	-0.045	86.08			0.187
LDNO EHV: Domestic Aggregated or CT with Residual		1, 2 or 0	5.517	0.440	0.044	3.87			
LDNO EHV: Domestic Aggregated (related MPAN)		2	5.517	0.440	0.044				
LDNO EHV: Non-Domestic Aggregated or CT No Residual		3 to 8 or 0	5.398	0.431	0.043	4.18			
LDNO EHV: Non-Domestic Aggregated or CT Band 1		3 to 8 or 0	5.398	0.431	0.043	4.89			
LDNO EHV: Non-Domestic Aggregated or CT Band 2		3 to 8 or 0	5.398	0.431	0.043	7.08			
LDNO EHV: Non-Domestic Aggregated or CT Band 3		3 to 8 or 0	5.398	0.431	0.043	10.01			
LDNO EHV: Non-Domestic Aggregated or CT Band 4		3 to 8 or 0	5.398	0.431	0.043	18.35			
LDNO EHV: Non-Domestic Aggregated (related MPAN)		4	5.398	0.431	0.043				
LDNO EHV: LV Site Specific No Residual		0	3.352	0.238	0.024	4.15	2.81	2.81	0.055
LDNO EHV: LV Site Specific Band 1		0	3.352	0.238	0.024	30.92	2.81	2.81	0.055
LDNO EHV: LV Site Specific Band 2		0	3.352	0.238	0.024	52.19	2.81	2.81	0.055
LDNO EHV: LV Site Specific Band 3		0	3.352	0.238	0.024	80.51	2.81	2.81	0.055
LDNO EHV: LV Site Specific Band 4		0	3.352	0.238	0.024	173.37	2.81	2.81	0.055
LDNO EHV: LV Sub Site Specific No Residual		0	3.613	0.182	0.020	5.48	4.07	4.07	0.051
LDNO EHV: LV Sub Site Specific Band 1		0	3.613	0.182	0.020	50.81	4.07	4.07	0.051
LDNO EHV: LV Sub Site Specific Band 2		0	3.613	0.182	0.020	86.83	4.07	4.07	0.051
LDNO EHV: LV Sub Site Specific Band 3		0	3.613	0.182	0.020	134.78	4.07	4.07	0.051
LDNO EHV: LV Sub Site Specific Band 4		0	3.613	0.182	0.020	291.99	4.07	4.07	0.051
LDNO EHV: HV Site Specific No Residual		0	3.239	0.124	0.014	59.40	4.58	4.58	0.042
LDNO EHV: HV Site Specific Band 1		0	3.239	0.124	0.014	446.99	4.58	4.58	0.042
LDNO EHV: HV Site Specific Band 2		0	3.239	0.124	0.014	953.69	4.58	4.58	0.042
LDNO EHV: HV Site Specific Band 3		0	3.239	0.124	0.014	2082.26	4.58	4.58	0.042
LDNO EHV: HV Site Specific Band 4		0	3.239	0.124	0.014	3955.57	4.58	4.58	0.042
LDNO EHV: Unmetered Supplies		0, 1 or 8	16.470	0.902	0.448				
LDNO EHV: LV Generation Aggregated		0	-5.621	-0.448	-0.044	0.00			
LDNO EHV: LV Sub Generation Aggregated		0	-5.661	-0.421	-0.042	0.00			
LDNO EHV: LV Generation Site Specific		0	-5.621	-0.448	-0.044	0.00			0.115
LDNO EHV: LV Sub Generation Site Specific		0	-5.661	-0.421	-0.042	0.00			0.097
LDNO EHV: HV Generation Site Specific		0	-6.382	-0.322	-0.035	67.02			0.146

Tariff name	Unique billing identifier	PCs	Red/black unit charge p/kWh	Amber/yellow unit charge p/kWh	Green unit charge p/kWh	Fixed charge p/MPAN/day	Capacity charge p/kVA/day	Exceeded capacity charge p/kVA/day	Reactive power charge p/kVArh
LDNO 132kV/EHV: Domestic Aggregated or CT with Residual		1, 2 or 0	4.218	0.336	0.033	2.96			
LDNO 132kV/EHV: Domestic Aggregated (related MPAN)		2	4.218	0.336	0.033				
LDNO 132kV/EHV: Non-Domestic Aggregated or CT No Residual		3 to 8 or 0	4.127	0.329	0.033	3.20			
LDNO 132kV/EHV: Non-Domestic Aggregated or CT Band 1		3 to 8 or 0	4.127	0.329	0.033	3.74			
LDNO 132kV/EHV: Non-Domestic Aggregated or CT Band 2		3 to 8 or 0	4.127	0.329	0.033	5.41			
LDNO 132kV/EHV: Non-Domestic Aggregated or CT Band 3		3 to 8 or 0	4.127	0.329	0.033	7.65			
LDNO 132kV/EHV: Non-Domestic Aggregated or CT Band 4		3 to 8 or 0	4.127	0.329	0.033	14.03			
LDNO 132kV/EHV: Non-Domestic Aggregated (related MPAN)		4	4.127	0.329	0.033				
LDNO 132kV/EHV: LV Site Specific No Residual		0	2.563	0.182	0.018	3.17	2.14	2.14	0.042
LDNO 132kV/EHV: LV Site Specific Band 1		0	2.563	0.182	0.018	23.64	2.14	2.14	0.042
LDNO 132kV/EHV: LV Site Specific Band 2		0	2.563	0.182	0.018	39.91	2.14	2.14	0.042
LDNO 132kV/EHV: LV Site Specific Band 3		0	2.563	0.182	0.018	61.56	2.14	2.14	0.042
LDNO 132kV/EHV: LV Site Specific Band 4		0	2.563	0.182	0.018	132.56	2.14	2.14	0.042
LDNO 132kV/EHV: LV Sub Site Specific No Residual		0	2.762	0.139	0.015	4.19	3.11	3.11	0.039
LDNO 132kV/EHV: LV Sub Site Specific Band 1		0	2.762	0.139	0.015	38.85	3.11	3.11	0.039
LDNO 132kV/EHV: LV Sub Site Specific Band 2		0	2.762	0.139	0.015	66.39	3.11	3.11	0.039
LDNO 132kV/EHV: LV Sub Site Specific Band 3		0	2.762	0.139	0.015	103.05	3.11	3.11	0.039
LDNO 132kV/EHV: LV Sub Site Specific Band 4		0	2.762	0.139	0.015	223.26	3.11	3.11	0.039
LDNO 132kV/EHV: HV Site Specific No Residual		0	2.476	0.095	0.011	45.41	3.51	3.51	0.032
LDNO 132kV/EHV: HV Site Specific Band 1		0	2.476	0.095	0.011	341.77	3.51	3.51	0.032
LDNO 132kV/EHV: HV Site Specific Band 2		0	2.476	0.095	0.011	729.18	3.51	3.51	0.032
LDNO 132kV/EHV: HV Site Specific Band 3		0	2.476	0.095	0.011	1592.07	3.51	3.51	0.032
LDNO 132kV/EHV: HV Site Specific Band 4		0	2.476	0.095	0.011	3024.39	3.51	3.51	0.032
LDNO 132kV/EHV: Unmetered Supplies		0, 1 or 8	12.593	0.689	0.343				
LDNO 132kV/EHV: LV Generation Aggregated		0	-4.298	-0.343	-0.034	0.00			
LDNO 132kV/EHV: LV Sub Generation Aggregated		0	-4.328	-0.322	-0.032	0.00			
LDNO 132kV/EHV: LV Generation Site Specific		0	-4.298	-0.343	-0.034	0.00			0.088
LDNO 132kV/EHV: LV Sub Generation Site Specific		0	-4.328	-0.322	-0.032	0.00			0.074

Tariff name	Unique billing identifier	PCs	Red/black unit charge p/kWh	Amber/yellow unit charge p/kWh	Green unit charge p/kWh	Fixed charge p/MPAN/day	Capacity charge p/kVA/day	Exceeded capacity charge p/kVA/day	Reactive power charge p/kVArh
LDNO 132kV/EHV: HV Generation Site Specific		0	-4.880	-0.246	-0.027	51.25			0.112
LDNO 132kV: Domestic Aggregated or CT with Residual		1, 2 or 0	2.941	0.235	0.023	2.06			
LDNO 132kV: Domestic Aggregated (related MPAN)		2	2.941	0.235	0.023				
LDNO 132kV: Non-Domestic Aggregated or CT No Residual		3 to 8 or 0	2.877	0.229	0.023	2.23			
LDNO 132kV: Non-Domestic Aggregated or CT Band 1		3 to 8 or 0	2.877	0.229	0.023	2.61			
LDNO 132kV: Non-Domestic Aggregated or CT Band 2		3 to 8 or 0	2.877	0.229	0.023	3.77			
LDNO 132kV: Non-Domestic Aggregated or CT Band 3		3 to 8 or 0	2.877	0.229	0.023	5.34			
LDNO 132kV: Non-Domestic Aggregated or CT Band 4		3 to 8 or 0	2.877	0.229	0.023	9.78			
LDNO 132kV: Non-Domestic Aggregated (related MPAN)		4	2.877	0.229	0.023				
LDNO 132kV: LV Site Specific No Residual		0	1.787	0.127	0.013	2.21	1.50	1.50	0.029
LDNO 132kV: LV Site Specific Band 1		0	1.787	0.127	0.013	16.48	1.50	1.50	0.029
LDNO 132kV: LV Site Specific Band 2		0	1.787	0.127	0.013	27.82	1.50	1.50	0.029
LDNO 132kV: LV Site Specific Band 3		0	1.787	0.127	0.013	42.91	1.50	1.50	0.029
LDNO 132kV: LV Site Specific Band 4		0	1.787	0.127	0.013	92.40	1.50	1.50	0.029
LDNO 132kV: LV Sub Site Specific No Residual		0	1.925	0.097	0.010	2.92	2.17	2.17	0.027
LDNO 132kV: LV Sub Site Specific Band 1		0	1.925	0.097	0.010	27.08	2.17	2.17	0.027
LDNO 132kV: LV Sub Site Specific Band 2		0	1.925	0.097	0.010	46.28	2.17	2.17	0.027
LDNO 132kV: LV Sub Site Specific Band 3		0	1.925	0.097	0.010	71.84	2.17	2.17	0.027
LDNO 132kV: LV Sub Site Specific Band 4		0	1.925	0.097	0.010	155.63	2.17	2.17	0.027
LDNO 132kV: HV Site Specific No Residual		0	1.726	0.066	0.008	31.66	2.44	2.44	0.022
LDNO 132kV: HV Site Specific Band 1		0	1.726	0.066	0.008	238.24	2.44	2.44	0.022
LDNO 132kV: HV Site Specific Band 2		0	1.726	0.066	0.008	508.30	2.44	2.44	0.022
LDNO 132kV: HV Site Specific Band 3		0	1.726	0.066	0.008	1109.80	2.44	2.44	0.022
LDNO 132kV: HV Site Specific Band 4		0	1.726	0.066	0.008	2108.24	2.44	2.44	0.022
LDNO 132kV: Unmetered Supplies		0, 1 or 8	8.778	0.481	0.239				
LDNO 132kV: LV Generation Aggregated		0	-2.996	-0.239	-0.024	0.00			
LDNO 132kV: LV Sub Generation Aggregated		0	-3.017	-0.224	-0.022	0.00			
LDNO 132kV: LV Generation Site Specific		0	-2.996	-0.239	-0.024	0.00			0.061
LDNO 132kV: LV Sub Generation Site Specific		0	-3.017	-0.224	-0.022	0.00			0.052
LDNO 132kV: HV Generation Site Specific		0	-3.401	-0.172	-0.019	35.72			0.078
LDNO 0000: Domestic Aggregated or CT with Residual		1, 2 or 0	1.230	0.098	0.010	0.86			
LDNO 0000: Domestic Aggregated (related MPAN)		2	1.230	0.098	0.010				

Tariff name	Unique billing identifier	PCs	Red/black unit charge p/kWh	Amber/yellow unit charge p/kWh	Green unit charge p/kWh	Fixed charge p/MPAN/day	Capacity charge p/kVA/day	Exceeded capacity charge p/kVA/day	Reactive power charge p/kVArh
LDNO 0000: Non-Domestic Aggregated or CT No Residual		3 to 8 or 0	1.204	0.096	0.009	0.93			
LDNO 0000: Non-Domestic Aggregated or CT Band 1		3 to 8 or 0	1.204	0.096	0.009	1.09			
LDNO 0000: Non-Domestic Aggregated or CT Band 2		3 to 8 or 0	1.204	0.096	0.009	1.58			
LDNO 0000: Non-Domestic Aggregated or CT Band 3		3 to 8 or 0	1.204	0.096	0.009	2.23			
LDNO 0000: Non-Domestic Aggregated or CT Band 4		3 to 8 or 0	1.204	0.096	0.009	4.09			
LDNO 0000: Non-Domestic Aggregated (related MPAN)		4	1.204	0.096	0.009				
LDNO 0000: LV Site Specific No Residual		0	0.747	0.053	0.005	0.92	0.63	0.63	0.012
LDNO 0000: LV Site Specific Band 1		0	0.747	0.053	0.005	6.89	0.63	0.63	0.012
LDNO 0000: LV Site Specific Band 2		0	0.747	0.053	0.005	11.64	0.63	0.63	0.012
LDNO 0000: LV Site Specific Band 3		0	0.747	0.053	0.005	17.95	0.63	0.63	0.012
LDNO 0000: LV Site Specific Band 4		0	0.747	0.053	0.005	38.66	0.63	0.63	0.012
LDNO 0000: LV Sub Site Specific No Residual		0	0.806	0.041	0.004	1.22	0.91	0.91	0.011
LDNO 0000: LV Sub Site Specific Band 1		0	0.806	0.041	0.004	11.33	0.91	0.91	0.011
LDNO 0000: LV Sub Site Specific Band 2		0	0.806	0.041	0.004	19.36	0.91	0.91	0.011
LDNO 0000: LV Sub Site Specific Band 3		0	0.806	0.041	0.004	30.05	0.91	0.91	0.011
LDNO 0000: LV Sub Site Specific Band 4		0	0.806	0.041	0.004	65.11	0.91	0.91	0.011
LDNO 0000: HV Site Specific No Residual		0	0.722	0.028	0.003	13.24	1.02	1.02	0.009
LDNO 0000: HV Site Specific Band 1		0	0.722	0.028	0.003	99.67	1.02	1.02	0.009
LDNO 0000: HV Site Specific Band 2		0	0.722	0.028	0.003	212.64	1.02	1.02	0.009
LDNO 0000: HV Site Specific Band 3		0	0.722	0.028	0.003	464.28	1.02	1.02	0.009
LDNO 0000: HV Site Specific Band 4		0	0.722	0.028	0.003	881.97	1.02	1.02	0.009
LDNO 0000: Unmetered Supplies		0, 1 or 8	3.672	0.201	0.100				
LDNO 0000: LV Generation Aggregated		0	-1.253	-0.100	-0.010	0.00			
LDNO 0000: LV Sub Generation Aggregated		0	-1.262	-0.094	-0.009	0.00			
LDNO 0000: LV Generation Site Specific		0	-1.253	-0.100	-0.010	0.00			0.026
LDNO 0000: LV Sub Generation Site Specific		0	-1.262	-0.094	-0.009	0.00			0.022
LDNO 0000: HV Generation Site Specific		0	-1.423	-0.072	-0.008	14.94			0.033

## Annex 4 - Charges applied to LDNOs with HV/LV end users in “Northern Powergrid (Yorkshire) Area (GSP Group \_M)”

### Southern Electric Power Distribution plc - Effective from 1st April 2027 - Final LDNO tariffs in NPG Yorkshire Area (GSP Group \_M)

Time Bands for LV and HV Properties			
Time periods	Red Time Band	Amber Time Band	Green Time Band
Monday to Friday (Including Bank Holidays) All Year	16:00 to 19:30	08:00 to 16:00 19:30 to 22:00	00:00 to 08:00 22:00 to 24:00
Saturday and Sunday All Year			00:00 to 24:00
Notes	All the above times are in UK Clock time		

Time Bands for Unmetered Properties			
	Black Time Band	Yellow Time Band	Green Time Band
Monday to Friday (Including Bank Holidays) November to February Inclusive	16:00 to 19:30	08:00 to 16:00 19:30 to 22:00	00:00 to 08:00 22:00 to 24:00
Monday to Friday (Including Bank Holidays) April to October Inclusive and March		08:00 to 22:00	00:00 to 08:00 22:00 to 24:00
Saturday and Sunday All year			00:00 to 24:00
Notes	All the above times are in UK Clock time		

Tariff name	Unique billing identifier	PCs	Red/black unit charge p/kWh	Amber/yellow unit charge p/kWh	Green unit charge p/kWh	Fixed charge p/MPAN/day	Capacity charge p/kVA/day	Exceeded capacity charge p/kVA/day	Reactive power charge p/kVArh
LDNO LV: Domestic Aggregated or CT with Residual		0, 1, 2	4.464	1.093	0.144	11.32			
LDNO LV: Domestic Aggregated (related MPAN)		2	4.464	1.093	0.144				
LDNO LV: Non-Domestic Aggregated or CT No Residual		0, 3, 4, 5-8	5.072	1.241	0.164	6.86			
LDNO LV: Non-Domestic Aggregated or CT Band 1		0, 3, 4, 5-8	5.072	1.241	0.164	11.74			
LDNO LV: Non-Domestic Aggregated or CT Band 2		0, 3, 4, 5-8	5.072	1.241	0.164	18.05			
LDNO LV: Non-Domestic Aggregated or CT Band 3		0, 3, 4, 5-8	5.072	1.241	0.164	30.08			
LDNO LV: Non-Domestic Aggregated or CT Band 4		0, 3, 4, 5-8	5.072	1.241	0.164	70.85			
LDNO LV: Non-Domestic Aggregated (related MPAN)		4	5.072	1.241	0.164				
LDNO LV: LV Site Specific No Residual		0	3.648	0.877	0.112	8.82	2.32	2.32	0.056
LDNO LV: LV Site Specific Band 1		0	3.648	0.877	0.112	118.92	2.32	2.32	0.056
LDNO LV: LV Site Specific Band 2		0	3.648	0.877	0.112	226.31	2.32	2.32	0.056
LDNO LV: LV Site Specific Band 3		0	3.648	0.877	0.112	341.78	2.32	2.32	0.056
LDNO LV: LV Site Specific Band 4		0	3.648	0.877	0.112	744.57	2.32	2.32	0.056

Tariff name	Unique billing identifier	PCs	Red/black unit charge p/kWh	Amber/yellow unit charge p/kWh	Green unit charge p/kWh	Fixed charge p/MPAN/day	Capacity charge p/kVA/day	Exceeded capacity charge p/kVA/day	Reactive power charge p/kVArh
LDNO LV: Unmetered Supplies		0, 1, 8	12.878	1.448	0.633				
LDNO LV: LV Generation Aggregated		0, 8	-5.382	-1.317	-0.174	0.00			
LDNO LV: LV Generation Site Specific		0	-5.382	-1.317	-0.174	0.00			0.076
LDNO HV: Domestic Aggregated or CT with Residual		0, 1, 2	3.081	0.754	0.099	7.81			
LDNO HV: Domestic Aggregated (Related MPAN)		2	3.081	0.754	0.099				
LDNO HV: Non-Domestic Aggregated or CT No Residual		0, 3, 4, 5-8	3.500	0.857	0.113	4.73			
LDNO HV: Non-Domestic Aggregated or CT Band 1		0, 3, 4, 5-8	3.500	0.857	0.113	8.10			
LDNO HV: Non-Domestic Aggregated or CT Band 2		0, 3, 4, 5-8	3.500	0.857	0.113	12.46			
LDNO HV: Non-Domestic Aggregated or CT Band 3		0, 3, 4, 5-8	3.500	0.857	0.113	20.76			
LDNO HV: Non-Domestic Aggregated or CT Band 4		0, 3, 4, 5-8	3.500	0.857	0.113	48.90			
LDNO HV: Non-Domestic Aggregated (related MPAN)		4	3.500	0.857	0.113				
LDNO HV: LV Site Specific No Residual		0	2.518	0.606	0.078	6.09	1.60	1.60	0.039
LDNO HV: LV Site Specific Band 1		0	2.518	0.606	0.078	82.08	1.60	1.60	0.039
LDNO HV: LV Site Specific Band 2		0	2.518	0.606	0.078	156.19	1.60	1.60	0.039
LDNO HV: LV Site Specific Band 3		0	2.518	0.606	0.078	235.89	1.60	1.60	0.039
LDNO HV: LV Site Specific Band 4		0	2.518	0.606	0.078	513.90	1.60	1.60	0.039
LDNO HV: LV Sub Site Specific No Residual		0	2.762	0.638	0.076	10.60	2.19	2.19	0.039
LDNO HV: LV Sub Site Specific Band 1		0	2.762	0.638	0.076	142.98	2.19	2.19	0.039
LDNO HV: LV Sub Site Specific Band 2		0	2.762	0.638	0.076	272.09	2.19	2.19	0.039
LDNO HV: LV Sub Site Specific Band 3		0	2.762	0.638	0.076	410.92	2.19	2.19	0.039
LDNO HV: LV Sub Site Specific Band 4		0	2.762	0.638	0.076	895.19	2.19	2.19	0.039
LDNO HV: HV Site Specific No Residual		0	2.331	0.512	0.055	347.22	3.52	3.52	0.029
LDNO HV: HV Site Specific Band 1		0	2.331	0.512	0.055	1460.95	3.52	3.52	0.029
LDNO HV: HV Site Specific Band 2		0	2.331	0.512	0.055	3621.76	3.52	3.52	0.029
LDNO HV: HV Site Specific Band 3		0	2.331	0.512	0.055	6770.69	3.52	3.52	0.029
LDNO HV: HV Site Specific Band 4		0	2.331	0.512	0.055	16723.91	3.52	3.52	0.029
LDNO HV: Unmetered Supplies		0, 1, 8	8.888	0.999	0.437				
LDNO HV: LV Generation Aggregated		0, 8	-5.382	-1.317	-0.174	0.00			
LDNO HV: LV Sub Generation Aggregated		8	-4.387	-1.063	-0.138	0.00			
LDNO HV: LV Generation Site Specific		0	-5.382	-1.317	-0.174	0.00			0.076
LDNO HV: LV Sub Generation Site Specific		0	-4.387	-1.063	-0.138	0.00			0.068
LDNO HV: HV Generation Site Specific		0	-3.097	-0.715	-0.085	0.00			0.060

Tariff name	Unique billing identifier	PCs	Red/black unit charge p/kWh	Amber/yellow unit charge p/kWh	Green unit charge p/kWh	Fixed charge p/MPAN/day	Capacity charge p/kVA/day	Exceeded capacity charge p/kVA/day	Reactive power charge p/kVArh
LDNO HVplus: Domestic Aggregated or CT with Residual		0, 1, 2	2.122	0.519	0.068	5.38			
LDNO HVplus: Domestic Aggregated (related MPAN)		2	2.122	0.519	0.068				
LDNO HVplus: Non-Domestic Aggregated or CT No Residual		0, 3, 4, 5-8	2.411	0.590	0.078	3.26			
LDNO HVplus: Non-Domestic Aggregated or CT Band 1		0, 3, 4, 5-8	2.411	0.590	0.078	5.58			
LDNO HVplus: Non-Domestic Aggregated or CT Band 2		0, 3, 4, 5-8	2.411	0.590	0.078	8.58			
LDNO HVplus: Non-Domestic Aggregated or CT Band 3		0, 3, 4, 5-8	2.411	0.590	0.078	14.30			
LDNO HVplus: Non-Domestic Aggregated or CT Band 4		0, 3, 4, 5-8	2.411	0.590	0.078	33.68			
LDNO HVplus: Non-Domestic Aggregated (related MPAN)		4	2.411	0.590	0.078				
LDNO HVplus: LV Site Specific No Residual		0	1.734	0.417	0.053	4.19	1.10	1.10	0.027
LDNO HVplus: LV Site Specific Band 1		0	1.734	0.417	0.053	56.53	1.10	1.10	0.027
LDNO HVplus: LV Site Specific Band 2		0	1.734	0.417	0.053	107.58	1.10	1.10	0.027
LDNO HVplus: LV Site Specific Band 3		0	1.734	0.417	0.053	162.47	1.10	1.10	0.027
LDNO HVplus: LV Site Specific Band 4		0	1.734	0.417	0.053	353.94	1.10	1.10	0.027
LDNO HVplus: LV Sub Site Specific No Residual		0	1.879	0.434	0.052	7.21	1.49	1.49	0.026
LDNO HVplus: LV Sub Site Specific Band 1		0	1.879	0.434	0.052	97.27	1.49	1.49	0.026
LDNO HVplus: LV Sub Site Specific Band 2		0	1.879	0.434	0.052	185.09	1.49	1.49	0.026
LDNO HVplus: LV Sub Site Specific Band 3		0	1.879	0.434	0.052	279.54	1.49	1.49	0.026
LDNO HVplus: LV Sub Site Specific Band 4		0	1.879	0.434	0.052	608.98	1.49	1.49	0.026
LDNO HVplus: HV Site Specific No Residual		0	1.569	0.345	0.037	233.74	2.37	2.37	0.020
LDNO HVplus: HV Site Specific Band 1		0	1.569	0.345	0.037	983.46	2.37	2.37	0.020
LDNO HVplus: HV Site Specific Band 2		0	1.569	0.345	0.037	2438.04	2.37	2.37	0.020
LDNO HVplus: HV Site Specific Band 3		0	1.569	0.345	0.037	4557.79	2.37	2.37	0.020
LDNO HVplus: HV Site Specific Band 4		0	1.569	0.345	0.037	11257.96	2.37	2.37	0.020
LDNO HVplus: Unmetered Supplies		0, 1, 8	6.121	0.688	0.301				
LDNO HVplus: LV Generation Aggregated		0, 8	-2.550	-0.624	-0.082	0.00			
LDNO HVplus: LV Sub Generation Aggregated		8	-2.573	-0.623	-0.081	0.00			
LDNO HVplus: LV Generation Site Specific		0	-2.550	-0.624	-0.082	0.00			0.036
LDNO HVplus: LV Sub Generation Site Specific		0	-2.573	-0.623	-0.081	0.00			0.040
LDNO HVplus: HV Generation Site Specific		0	-3.097	-0.715	-0.085	88.59			0.060
LDNO EHV: Domestic Aggregated or CT with Residual		0, 1, 2	1.470	0.360	0.047	3.73			

Tariff name	Unique billing identifier	PCs	Red/black unit charge p/kWh	Amber/yellow unit charge p/kWh	Green unit charge p/kWh	Fixed charge p/MPAN/day	Capacity charge p/kVA/day	Exceeded capacity charge p/kVA/day	Reactive power charge p/kVArh
LDNO EHV: Domestic Aggregated (related MPAN)		2	1.470	0.360	0.047				
LDNO EHV: Non-Domestic Aggregated or CT No Residual		0, 3, 4, 5-8	1.671	0.409	0.054	2.26			
LDNO EHV: Non-Domestic Aggregated or CT Band 1		0, 3, 4, 5-8	1.671	0.409	0.054	3.87			
LDNO EHV: Non-Domestic Aggregated or CT Band 2		0, 3, 4, 5-8	1.671	0.409	0.054	5.95			
LDNO EHV: Non-Domestic Aggregated or CT Band 3		0, 3, 4, 5-8	1.671	0.409	0.054	9.91			
LDNO EHV: Non-Domestic Aggregated or CT Band 4		0, 3, 4, 5-8	1.671	0.409	0.054	23.34			
LDNO EHV: Non-Domestic Aggregated (related MPAN)		4	1.671	0.409	0.054				
LDNO EHV: LV Site Specific No Residual		0	1.202	0.289	0.037	2.91	0.76	0.76	0.019
LDNO EHV: LV Site Specific Band 1		0	1.202	0.289	0.037	39.18	0.76	0.76	0.019
LDNO EHV: LV Site Specific Band 2		0	1.202	0.289	0.037	74.55	0.76	0.76	0.019
LDNO EHV: LV Site Specific Band 3		0	1.202	0.289	0.037	112.60	0.76	0.76	0.019
LDNO EHV: LV Site Specific Band 4		0	1.202	0.289	0.037	245.29	0.76	0.76	0.019
LDNO EHV: LV Sub Site Specific No Residual		0	1.302	0.301	0.036	5.00	1.03	1.03	0.018
LDNO EHV: LV Sub Site Specific Band 1		0	1.302	0.301	0.036	67.41	1.03	1.03	0.018
LDNO EHV: LV Sub Site Specific Band 2		0	1.302	0.301	0.036	128.28	1.03	1.03	0.018
LDNO EHV: LV Sub Site Specific Band 3		0	1.302	0.301	0.036	193.73	1.03	1.03	0.018
LDNO EHV: LV Sub Site Specific Band 4		0	1.302	0.301	0.036	422.05	1.03	1.03	0.018
LDNO EHV: HV Site Specific No Residual		0	1.088	0.239	0.026	161.99	1.64	1.64	0.014
LDNO EHV: HV Site Specific Band 1		0	1.088	0.239	0.026	681.57	1.64	1.64	0.014
LDNO EHV: HV Site Specific Band 2		0	1.088	0.239	0.026	1689.65	1.64	1.64	0.014
LDNO EHV: HV Site Specific Band 3		0	1.088	0.239	0.026	3158.71	1.64	1.64	0.014
LDNO EHV: HV Site Specific Band 4		0	1.088	0.239	0.026	7802.16	1.64	1.64	0.014
LDNO EHV: Unmetered Supplies		0, 1, 8	4.242	0.477	0.209				
LDNO EHV: LV Generation Aggregated		0, 8	-1.767	-0.433	-0.057	0.00			
LDNO EHV: LV Sub Generation Aggregated		8	-1.783	-0.432	-0.056	0.00			
LDNO EHV: LV Generation Site Specific		0	-1.767	-0.433	-0.057	0.00			0.025
LDNO EHV: LV Sub Generation Site Specific		0	-1.783	-0.432	-0.056	0.00			0.028
LDNO EHV: HV Generation Site Specific		0	-2.146	-0.495	-0.059	61.40			0.042
LDNO 132kV/EHV: Domestic Aggregated or CT with Residual		0, 1, 2	0.991	0.243	0.032	2.51			
LDNO 132kV/EHV: Domestic Aggregated (related MPAN)		2	0.991	0.243	0.032				

Tariff name	Unique billing identifier	PCs	Red/black unit charge p/kWh	Amber/yellow unit charge p/kWh	Green unit charge p/kWh	Fixed charge p/MPAN/day	Capacity charge p/kVA/day	Exceeded capacity charge p/kVA/day	Reactive power charge p/kVArh
LDNO 132kV/EHV: Non-Domestic Aggregated or CT No Residual		0, 3, 4, 5-8	1.126	0.276	0.036	1.52			
LDNO 132kV/EHV: Non-Domestic Aggregated or CT Band 1		0, 3, 4, 5-8	1.126	0.276	0.036	2.61			
LDNO 132kV/EHV: Non-Domestic Aggregated or CT Band 2		0, 3, 4, 5-8	1.126	0.276	0.036	4.01			
LDNO 132kV/EHV: Non-Domestic Aggregated or CT Band 3		0, 3, 4, 5-8	1.126	0.276	0.036	6.68			
LDNO 132kV/EHV: Non-Domestic Aggregated or CT Band 4		0, 3, 4, 5-8	1.126	0.276	0.036	15.74			
LDNO 132kV/EHV: Non-Domestic Aggregated (related MPAN)		4	1.126	0.276	0.036				
LDNO 132kV/EHV: LV Site Specific No Residual		0	0.810	0.195	0.025	1.96	0.52	0.52	0.012
LDNO 132kV/EHV: LV Site Specific Band 1		0	0.810	0.195	0.025	26.41	0.52	0.52	0.012
LDNO 132kV/EHV: LV Site Specific Band 2		0	0.810	0.195	0.025	50.26	0.52	0.52	0.012
LDNO 132kV/EHV: LV Site Specific Band 3		0	0.810	0.195	0.025	75.91	0.52	0.52	0.012
LDNO 132kV/EHV: LV Site Specific Band 4		0	0.810	0.195	0.025	165.37	0.52	0.52	0.012
LDNO 132kV/EHV: LV Sub Site Specific No Residual		0	0.878	0.203	0.024	3.37	0.70	0.70	0.012
LDNO 132kV/EHV: LV Sub Site Specific Band 1		0	0.878	0.203	0.024	45.45	0.70	0.70	0.012
LDNO 132kV/EHV: LV Sub Site Specific Band 2		0	0.878	0.203	0.024	86.48	0.70	0.70	0.012
LDNO 132kV/EHV: LV Sub Site Specific Band 3		0	0.878	0.203	0.024	130.61	0.70	0.70	0.012
LDNO 132kV/EHV: LV Sub Site Specific Band 4		0	0.878	0.203	0.024	284.53	0.70	0.70	0.012
LDNO 132kV/EHV: HV Site Specific No Residual		0	0.733	0.161	0.017	109.21	1.11	1.11	0.009
LDNO 132kV/EHV: HV Site Specific Band 1		0	0.733	0.161	0.017	459.49	1.11	1.11	0.009
LDNO 132kV/EHV: HV Site Specific Band 2		0	0.733	0.161	0.017	1139.11	1.11	1.11	0.009
LDNO 132kV/EHV: HV Site Specific Band 3		0	0.733	0.161	0.017	2129.50	1.11	1.11	0.009
LDNO 132kV/EHV: HV Site Specific Band 4		0	0.733	0.161	0.017	5259.96	1.11	1.11	0.009
LDNO 132kV/EHV: Unmetered Supplies		0, 1, 8	2.860	0.322	0.141				
LDNO 132kV/EHV: LV Generation Aggregated		0, 8	-1.192	-0.292	-0.038	0.00			
LDNO 132kV/EHV: LV Sub Generation Aggregated		8	-1.202	-0.291	-0.038	0.00			
LDNO 132kV/EHV: LV Generation Site Specific		0	-1.192	-0.292	-0.038	0.00			0.017
LDNO 132kV/EHV: LV Sub Generation Site Specific		0	-1.202	-0.291	-0.038	0.00			0.019
LDNO 132kV/EHV: HV Generation Site Specific		0	-1.447	-0.334	-0.040	41.39			0.028
LDNO 132kV: Domestic Aggregated or CT with Residual		0, 1, 2	0.516	0.126	0.017	1.31			
LDNO 132kV: Domestic Aggregated (related MPAN)		2	0.516	0.126	0.017				

Tariff name	Unique billing identifier	PCs	Red/black unit charge p/kWh	Amber/yellow unit charge p/kWh	Green unit charge p/kWh	Fixed charge p/MPAN/day	Capacity charge p/kVA/day	Exceeded capacity charge p/kVA/day	Reactive power charge p/kVArh
LDNO 132kV: Non-Domestic Aggregated or CT No Residual		0, 3, 4, 5-8	0.586	0.143	0.019	0.79			
LDNO 132kV: Non-Domestic Aggregated or CT Band 1		0, 3, 4, 5-8	0.586	0.143	0.019	1.36			
LDNO 132kV: Non-Domestic Aggregated or CT Band 2		0, 3, 4, 5-8	0.586	0.143	0.019	2.08			
LDNO 132kV: Non-Domestic Aggregated or CT Band 3		0, 3, 4, 5-8	0.586	0.143	0.019	3.47			
LDNO 132kV: Non-Domestic Aggregated or CT Band 4		0, 3, 4, 5-8	0.586	0.143	0.019	8.18			
LDNO 132kV: Non-Domestic Aggregated (related MPAN)		4	0.586	0.143	0.019				
LDNO 132kV: LV Site Specific No Residual		0	0.421	0.101	0.013	1.02	0.27	0.27	0.006
LDNO 132kV: LV Site Specific Band 1		0	0.421	0.101	0.013	13.74	0.27	0.27	0.006
LDNO 132kV: LV Site Specific Band 2		0	0.421	0.101	0.013	26.14	0.27	0.27	0.006
LDNO 132kV: LV Site Specific Band 3		0	0.421	0.101	0.013	39.48	0.27	0.27	0.006
LDNO 132kV: LV Site Specific Band 4		0	0.421	0.101	0.013	86.00	0.27	0.27	0.006
LDNO 132kV: LV Sub Site Specific No Residual		0	0.457	0.105	0.013	1.75	0.36	0.36	0.006
LDNO 132kV: LV Sub Site Specific Band 1		0	0.457	0.105	0.013	23.63	0.36	0.36	0.006
LDNO 132kV: LV Sub Site Specific Band 2		0	0.457	0.105	0.013	44.97	0.36	0.36	0.006
LDNO 132kV: LV Sub Site Specific Band 3		0	0.457	0.105	0.013	67.92	0.36	0.36	0.006
LDNO 132kV: LV Sub Site Specific Band 4		0	0.457	0.105	0.013	147.97	0.36	0.36	0.006
LDNO 132kV: HV Site Specific No Residual		0	0.381	0.084	0.009	56.79	0.58	0.58	0.005
LDNO 132kV: HV Site Specific Band 1		0	0.381	0.084	0.009	238.96	0.58	0.58	0.005
LDNO 132kV: HV Site Specific Band 2		0	0.381	0.084	0.009	592.40	0.58	0.58	0.005
LDNO 132kV: HV Site Specific Band 3		0	0.381	0.084	0.009	1107.45	0.58	0.58	0.005
LDNO 132kV: HV Site Specific Band 4		0	0.381	0.084	0.009	2735.46	0.58	0.58	0.005
LDNO 132kV: Unmetered Supplies		0, 1, 8	1.487	0.167	0.073				
LDNO 132kV: LV Generation Aggregated		0, 8	-0.620	-0.152	-0.020	0.00			
LDNO 132kV: LV Sub Generation Aggregated		8	-0.625	-0.151	-0.020	0.00			
LDNO 132kV: LV Generation Site Specific		0	-0.620	-0.152	-0.020	0.00			0.009
LDNO 132kV: LV Sub Generation Site Specific		0	-0.625	-0.151	-0.020	0.00			0.010
LDNO 132kV: HV Generation Site Specific		0	-0.752	-0.174	-0.021	21.53			0.015
LDNO 0000: Domestic Aggregated or CT with Residual		0, 1, 2	0.214	0.052	0.007	0.54			
LDNO 0000: Domestic Aggregated (related MPAN)		2	0.214	0.052	0.007				
LDNO 0000: Non-Domestic Aggregated or CT No Residual		0, 3, 4, 5-8	0.243	0.059	0.008	0.33			
LDNO 0000: Non-Domestic Aggregated or CT Band 1		0, 3, 4, 5-8	0.243	0.059	0.008	0.56			

Tariff name	Unique billing identifier	PCs	Red/black unit charge p/kWh	Amber/yellow unit charge p/kWh	Green unit charge p/kWh	Fixed charge p/MPAN/day	Capacity charge p/kVA/day	Exceeded capacity charge p/kVA/day	Reactive power charge p/kVArh
LDNO 0000: Non-Domestic Aggregated or CT Band 2		0, 3, 4, 5-8	0.243	0.059	0.008	0.86			
LDNO 0000: Non-Domestic Aggregated or CT Band 3		0, 3, 4, 5-8	0.243	0.059	0.008	1.44			
LDNO 0000: Non-Domestic Aggregated or CT Band 4		0, 3, 4, 5-8	0.243	0.059	0.008	3.39			
LDNO 0000: Non-Domestic Aggregated (related MPAN)		4	0.243	0.059	0.008				
LDNO 0000: LV Site Specific No Residual		0	0.175	0.042	0.005	0.42	0.11	0.11	0.003
LDNO 0000: LV Site Specific Band 1		0	0.175	0.042	0.005	5.70	0.11	0.11	0.003
LDNO 0000: LV Site Specific Band 2		0	0.175	0.042	0.005	10.84	0.11	0.11	0.003
LDNO 0000: LV Site Specific Band 3		0	0.175	0.042	0.005	16.37	0.11	0.11	0.003
LDNO 0000: LV Site Specific Band 4		0	0.175	0.042	0.005	35.66	0.11	0.11	0.003
LDNO 0000: LV Sub Site Specific No Residual		0	0.189	0.044	0.005	0.73	0.15	0.15	0.003
LDNO 0000: LV Sub Site Specific Band 1		0	0.189	0.044	0.005	9.80	0.15	0.15	0.003
LDNO 0000: LV Sub Site Specific Band 2		0	0.189	0.044	0.005	18.65	0.15	0.15	0.003
LDNO 0000: LV Sub Site Specific Band 3		0	0.189	0.044	0.005	28.16	0.15	0.15	0.003
LDNO 0000: LV Sub Site Specific Band 4		0	0.189	0.044	0.005	61.36	0.15	0.15	0.003
LDNO 0000: HV Site Specific No Residual		0	0.158	0.035	0.004	23.55	0.24	0.24	0.002
LDNO 0000: HV Site Specific Band 1		0	0.158	0.035	0.004	99.09	0.24	0.24	0.002
LDNO 0000: HV Site Specific Band 2		0	0.158	0.035	0.004	245.64	0.24	0.24	0.002
LDNO 0000: HV Site Specific Band 3		0	0.158	0.035	0.004	459.21	0.24	0.24	0.002
LDNO 0000: HV Site Specific Band 4		0	0.158	0.035	0.004	1134.26	0.24	0.24	0.002
LDNO 0000: Unmetered Supplies		0, 1, 8	0.617	0.069	0.030				
LDNO 0000: LV Generation Aggregated		0, 8	-0.257	-0.063	-0.008	0.00			
LDNO 0000: LV Sub Generation Aggregated		8	-0.259	-0.063	-0.008	0.00			
LDNO 0000: LV Generation Site Specific		0	-0.257	-0.063	-0.008	0.00			0.004
LDNO 0000: LV Sub Generation Site Specific		0	-0.259	-0.063	-0.008	0.00			0.004
LDNO 0000: HV Generation Site Specific		0	-0.312	-0.072	-0.009	8.93			0.006

## Annex 5 – Schedule of Line Loss Factors in “Eastern Power Networks Area (GSP Group \_A)”

LLF time periods:

Southern Electric Power Distribution plc - Illustrative LLFs in UKPN EPN Area (GSP Group _A) for year beginning 1 April 2027					
Time periods	Period 1	Period 2	Period 3	Period 4	Period 5
	Winter Weekday Peak	Summer Weekday Peak	Winter Weekday	Other	Night
Monday to Friday November to February	16:00 – 20:00		07:00 – 16:00		
Monday to Friday June to August		07:00 – 20:00			
Monday to Friday March			07:00 – 20:00		
All Year				All Other Times	00:00 – 07:00
Notes	All times are in UK Clock time				

Generic Demand and Generation LLFs						
Metered Voltage, Respective Periods and Associated LLFCs / DUoS Tariff IDs						
Metered Voltage	Period 1	Period 2	Period 3	Period 4	Period 5	Associated LLFC / DUoS Tariff ID
Low-voltage network						
Low-voltage substation						
High-voltage network						
High-voltage substation						
33kV generic						
132kV generic						

EHV Site Specific LLFs						
Demand						
Site	Period 1	Period 2	Period 3	Period 4	Period 5	Associated LLFC / DUoS Tariff ID

EHV Site Specific LLFs						
Generation						
Site	Period 1	Period 2	Period 3	Period 4	Period 5	Associated LLFC / DUoS Tariff ID

## Annex 5 – Schedule of Line Loss Factors in “NGED East Midlands Area (GSP Group \_B)”

LLF time periods:

Southern Electric Power Distribution plc - Illustrative LLFs in NGED EM Area (GSP Group _B) for year beginning 1st April 2027				
Time periods	Period 1	Period 2	Period 3	Period 4
	Winter Weekday Peak	Winter Weekday	Other	Night
Monday to Friday Mar to Oct			07:30 – 00:30	00:30 – 07:30
Monday to Friday Nov to Feb	16:00 – 19:00	07:30 – 16:00 19:00 – 20:00	20:00 – 00:30	00:30 – 07:30
Saturday and Sunday All Year			07:30 – 00:30	00:30 – 07:30
Notes	All the above times are in UK Clock time			

Generic Demand and Generation LLFs					
Metered voltage, respective periods and associated LLFCs / DUoS Tariff IDs					
Metered Voltage	Period 1	Period 2	Period 3	Period 4	Associated LLFC / DUoS Tariff ID
Low Voltage Network					
Low Voltage Substation					
High Voltage Network					
High Voltage Substation					
33kV generic					
33kV generic					
132kV generic					
132kV generic					

EHV site specific LLFs					
Demand					
Site	Period 1	Period 2	Period 3	Period 4	Associated LLFC / DUoS Tariff ID

EHV site specific LLFs					
Generation					
Site	Period 1	Period 2	Period 3	Period 4	Associated LLFC / DUoS Tariff ID

## Annex 5 – Schedule of Line Loss Factors in “London Power Networks Area (GSP Group \_C)”

LLF time periods:

Southern Electric Power Distribution plc - Illustrative LLFs in UKPN LPN Area (GSP Group _C) for year beginning 1st April 2027					
Time periods	Period 1	Period 2	Period 3	Period 4	Period 5
	Winter Weekday Peak	Summer Weekday Peak	Winter Weekday	Other	Night
Monday to Friday November to February	16:00 – 20:00		07:00 – 16:00		
Monday to Friday June to August		07:00 – 20:00			
Monday to Friday March			07:00 – 20:00		
All Year				All Other Times	00:00 – 07:00
Notes	All times are in UK Clock time				

Generic Demand and Generation LLFs						
Metered Voltage, Respective Periods and Associated LLFCs / DUoS Tariff IDs						
Metered voltage	Period 1	Period 2	Period 3	Period 4	Period 5	Associated LLFC / DUoS Tariff ID
Low-voltage network						
Low-voltage substation						
High-voltage network						
High-voltage substation						
33kV generic						
132kV generic						

EHV Site Specific LLFs						
Demand						
Site	Period 1	Period 2	Period 3	Period 4	Period 5	Associated LLFC / DUoS Tariff ID

EHV Site Specific LLFs						
Generation						
Site	Period 1	Period 2	Period 3	Period 4	Period 5	Associated LLFC / DUoS Tariff ID

## Annex 5 – Schedule of Line Loss Factors in “SP Manweb Area (GSP Group \_D)”

LLF time periods:

Southern Electric Power Distribution plc - Illustrative LLFs in SP Manweb Area (GSP Group _D) for year beginning 1 April 2027				
Time periods	Period 1	Period 2	Period 3	Period 4
	Winter Weekday Peak	Winter Weekday	Other	Night
Monday to Friday March to October			07:30 – 23:30	23:30 – 07:30
Monday to Friday November to February	16:00 – 19:00	07:30 – 16:00 19:00 – 20:00	20:00 – 23:30	23:30 – 07:30
Saturday and Sunday All Year			07:30 – 23:30	23:30 – 07:30
Notes	All the above times are in UK Clock time			

Generic demand and generation LLFs					
Metered voltage, respective periods and associated LLFCs / DUoS Tariff IDs					
Metered voltage	Period 1	Period 2	Period 3	Period 4	Associated LLFC / DUoS Tariff ID
Low Voltage Network					
Low Voltage Substation					
High Voltage Network					
High Voltage Substation					
33kV generic					
33kV generic					
132kV generic					
132kV generic					

EHV site specific LLFs					
Demand					
Site	Period 1	Period 2	Period 3	Period 4	Associated LLFC / DUoS Tariff ID

EHV site specific LLFs					
Generation					
Site	Period 1	Period 2	Period 3	Period 4	Associated LLFC / DUoS Tariff ID

## Annex 5 – Schedule of Line Loss Factors in “NGED West Midlands Area (GSP Group \_E)”

LLF time periods:

Southern Electric Power Distribution plc - Illustrative LLFs in NGED West Midlands Area (GSP Group _E) for year beginning 1st April 2027				
Time periods	Period 1	Period 2	Period 3	Period 4
	Winter Weekday Peak	Winter Weekday	Other	Night
Monday to Friday Mar to Oct			07:30 – 00:30	00:30 – 07:30
Monday to Friday Nov to Feb	16:00 – 19:00	07:30 – 16:00 19:00 – 20:00	20:00 – 00:30	00:30 – 07:30
Saturday and Sunday All Year			07:30 – 00:30	00:30 – 07:30
Notes	All the above times are in UK Clock time			

Generic Demand and Generation LLFs					
Metered voltage, respective periods and associated LLFCs / DUoS Tariff IDs					
Metered Voltage	Period 1	Period 2	Period 3	Period 4	Associated LLFC / DUoS Tariff ID
Low Voltage Network					
Low Voltage Substation					
High Voltage Network					
High Voltage Substation					
33kV generic					
33kV generic					
132kV generic					
132kV generic					

EHV site specific LLFs					
Demand					
Site	Period 1	Period 2	Period 3	Period 4	Associated LLFC / DUoS Tariff ID

EHV site specific LLFs					
Generation					
Site	Period 1	Period 2	Period 3	Period 4	Associated LLFC / DUoS Tariff ID

## Annex 5 – Schedule of Line Loss Factors in “Northern Powergrid (Northeast) Area (GSP Group \_F)”

LLF time periods:

Southern Electric Power Distribution plc - Illustrative LLFs in NPG Northeast Area (GSP Group _F) for year beginning 1st April 2027				
Time periods	Period 1	Period 2	Period 3	Period 4
	Winter Weekday Peak	Winter Weekday	Other	Night
<b>Notes</b>	All the above times are in UK Clock time			

Generic demand and generation LLFs					
Metered voltage, respective periods and associated LLFCs / DUoS Tariff IDs					
Metered voltage	Period 1	Period 2	Period 3	Period 4	Associated LLFC / DUoS Tariff ID
Low Voltage Network					
Low Voltage Substation					
High Voltage Network					
High Voltage Substation					
Greater than 22kV connected - generation					
Greater than 22kV connected - demand					

EHV site specific LLFs					
Demand					
Site	Period 1	Period 2	Period 3	Period 4	Associated LLFC / DUoS Tariff ID

EHV site specific LLFs					
Generation					
Site	Period 1	Period 2	Period 3	Period 4	Associated LLFC / DUoS Tariff ID

**Annex 5 – Schedule of Line Loss Factors in “Northern Powergrid (Northeast) Area (GSP Group \_F)”**

LLF time periods:

Southern Electric Power Distribution plc - Illustrative LLFs in NPG Northeast Area (GSP Group _F) for year beginning 1st April 2027				
Time periods	Period 1	Period 2	Period 3	Period 4
	Winter Weekday Peak	Winter Weekday	Other	Night
<b>Notes</b>	All the above times are in UK Clock time			

Generic demand and generation LLFs					
Metered voltage, respective periods and associated LLFCs / DUoS Tariff IDs					
Metered voltage	Period 1	Period 2	Period 3	Period 4	Associated LLFC / DUoS Tariff ID
Low Voltage Network					
High Voltage Network					

EHV site specific LLFs					
Demand					
Site	Period 1	Period 2	Period 3	Period 4	Associated LLFC / DUoS Tariff ID

EHV site specific LLFs					
Generation					
Site	Period 1	Period 2	Period 3	Period 4	Associated LLFC / DUoS Tariff ID

## Annex 5 – Schedule of Line Loss Factors in “SP Electricity North West Area (GSP Group \_G)”

LLF time periods:

Southern Electric Power Distribution plc - Illustrative LLFs in SP Electricity North West Area (GSP Group _G) for year beginning 1st April 2027				
Time periods	Period 1	Period 2	Period 3	Period 4
	Winter Weekday Peak	Winter Weekday	Other	Night
<b>Notes</b>	All the above times are in UK Clock time			

Generic demand and generation LLFs					
Metered voltage, respective periods and associated LLFCs / DUoS Tariff IDs					
Metered voltage	Period 1	Period 2	Period 3	Period 4	Associated LLFC / DUoS Tariff ID
Low-voltage network					
Low-voltage substation					
High-voltage network					
High-voltage substation					
33kV generic					
33kV generic					
132kV generic					
132kV generic					

EHV site specific LLFs					
Demand					
Site	Period 1	Period 2	Period 3	Period 4	Associated LLFC / DUoS Tariff ID

EHV site specific LLFs					
Generation					
Site	Period 1	Period 2	Period 3	Period 4	Associated LLFC / DUoS Tariff ID

## Annex 5 – Schedule of Line Loss Factors in “South Eastern Power Networks Area (GSP Group \_J)”

LLF time periods:

Southern Electric Power Distribution plc - Illustrative LLFs in UKPN SPN Area (GSP Group _J) for year beginning 1st April 2027					
Time periods	Period 1	Period 2	Period 3	Period 4	Period 5
	Winter Weekday Peak	Summer Weekday Peak	Winter Weekday	Other	Night
Monday to Friday November to February	16:00 – 20:00		07:00 – 16:00		
Monday to Friday June to August		07:00 – 20:00			
Monday to Friday March			07:00 – 20:00		
All Year				All Other Times	00:00 – 07:00
Notes	All times are in UK Clock time				

Generic Demand and Generation LLFs						
Metered voltage, respective periods and associated LLFCs / DUoS Tariff IDs						
Metered voltage	Period 1	Period 2	Period 3	Period 4	Period 5	Associated LLFC / DUoS Tariff ID
Low-voltage network						
Low-voltage substation						
High-voltage network						
High-voltage substation						
33kV generic						
132kV generic						

EHV Site Specific LLFs						
Demand						
Site	Period 1	Period 2	Period 3	Period 4	Period 5	Associated LLFC / DUoS Tariff ID

EHV Site Specific LLFs						
Generation						
Site	Period 1	Period 2	Period 3	Period 4	Period 5	Associated LLFC / DUoS Tariff ID

## Annex 5 – Schedule of Line Loss Factors in “NGED South Wales Area (GSP Group \_K)”

LLF time periods:

Southern Electric Power Distribution plc - Illustrative LLFs in NGED South Wales Area (GSP Group _K) for year beginning 1st April 2027				
Time periods	Period 1	Period 2	Period 3	Period 4
	Winter Weekday Peak	Winter Weekday	Other	Night
Monday to Friday Mar to Oct			00:00 - 00:30 07:30 - 24:00	00:30 - 07:30
Monday to Friday Nov to Feb	16:00 – 19:00	07:30 – 16:00	00:00 - 00:30 19:00 - 24:00	00:30 - 07:30
Saturday and Sunday All Year			00:00 - 00:30 07:30 - 24:00	00:30 - 07:30
Notes	All the above times are in UK Clock time			

Generic demand and generation LLFs					
Metered voltage, respective periods and associated LLFCs / DUoS Tariff IDs					
Metered voltage	Period 1	Period 2	Period 3	Period 4	Associated LLFC / DUoS Tariff ID
Low Voltage Network					
Low Voltage Substation					
High Voltage Network					
High Voltage Substation					
33kV generic					
33kV generic					
132kV generic					
132kV generic					

EHV site specific LLFs					
Demand					
Site	Period 1	Period 2	Period 3	Period 4	Associated LLFC / DUoS Tariff ID

EHV site specific LLFs					
Generation					
Site	Period 1	Period 2	Period 3	Period 4	Associated LLFC / DUoS Tariff ID

## Annex 5 – Schedule of Line Loss Factors in “NGED South West Area (GSP Group \_L)”

LLF time periods:

Southern Electric Power Distribution plc - Illustrative LLFs in NGED South West Area (GSP Group _L) for year beginning 1st April 2027				
Time periods	Period 1	Period 2	Period 3	Period 4
	Winter Weekday Peak	Winter Weekday	Other	Night
Monday to Friday Mar to Oct			06:30 - 23:30	00:00 - 06:30 23:30 - 24:00
Monday to Friday Nov to Feb	16:00 - 19:00	06:30 - 16:00	19:00 - 23:30	00:00 - 06:30 23:30 - 24:00
Saturday and Sunday All Year			06:30 - 23:30	00:00 - 06:30 23:30 - 24:00
Notes	All the above times are in UK Clock time			

Generic demand and generation LLFs					
Metered voltage, respective periods and associated LLFCs / DUoS Tariff IDs					
Metered voltage	Period 1	Period 2	Period 3	Period 4	Associated LLFC / DUoS Tariff ID
Low Voltage Network					
Low Voltage Substation					
High Voltage Network					
High Voltage Substation					
33kV generic					
33kV generic					
132kV generic					
132kV generic					

EHV site specific LLFs					
Demand					
Site	Period 1	Period 2	Period 3	Period 4	Associated LLFC / DUoS Tariff ID

EHV site specific LLFs					
Generation					
Site	Period 1	Period 2	Period 3	Period 4	Associated LLFC / DUoS Tariff ID

## Annex 5 – Schedule of Line Loss Factors in “Northern Powergrid (Yorkshire) Area (GSP Group \_M)”

LLF time periods:

Southern Electric Power Distribution plc - Illustrative LLFs in NPG Yorkshire Area (GSP Group _M) for year beginning 1st April 2027				
Time periods	Period 1	Period 2	Period 3	Period 4
	Winter Weekday Peak	Winter Weekday	Other	Night
<b>Notes</b>	All the above times are in UK Clock time			

Generic demand and generation LLFs					
Metered voltage, respective periods and associated LLFCs / DUoS Tariff IDs					
Metered voltage	Period 1	Period 2	Period 3	Period 4	Associated LLFC / DUoS Tariff ID
Low Voltage Network					
Low Voltage Substation					
High Voltage Network					
High Voltage Substation					
Greater than 22kV connected - generation					
Greater than 22kV connected - demand					

EHV site specific LLFs					
Demand					
Site	Period 1	Period 2	Period 3	Period 4	Associated LLFC / DUoS Tariff ID

EHV site specific LLFs					
Generation					
Site	Period 1	Period 2	Period 3	Period 4	Associated LLFC / DUoS Tariff ID

**Annex 6 – Charges for New or Amended EHV Properties in “Eastern Power Networks Area (GSP Group \_A)”**

Southern Electric Power Distribution plc - Effective from 1 April 2027 - Final new or amended EHV charges in UKPN EPN Area (GSP Group _A)														
Effective from date	Import LLFC / DUoS Tariff ID	Import MPANs/MSIDs	Export LLFC / DUoS Tariff ID	Export MPANs/MSIDs	Name	Residual Charging Band	Import Super Red unit charge (p/kWh)	Import fixed charge (p/day)	Import capacity charge (p/kVA/day)	Import exceeded capacity charge (p/kVA/day)	Export Super Red unit charge (p/kWh)	Export fixed charge (p/day)	Export capacity charge (p/kVA/day)	Export exceeded capacity charge (p/kVA/day)

Southern Electric Power Distribution plc - Effective from 1 April 2027 - Final new or amended EHV line loss factors in UKPN EPN Area (GSP Group _A)																
Effective from date	Import LLFC / DUoS Tariff ID	Import MPANs/MSIDs	Export LLFC / DUoS Tariff ID	Export MPANs/MSIDs	Name	Residual Charging Band	Import LLF period 1	Import LLF period 2	Import LLF period 3	Import LLF period 4	Import LLF period 5	Export LLF period 1	Export LLF period 2	Export LLF period 3	Export LLF period 4	Export LLF period 5

**Annex 6 – Charges for New or Amended EHV Properties in “NGED East Midlands Area (GSP Group \_B)”**

Southern Electric Power Distribution plc - Effective from 1 April 2027 - Final new or amended EHV charges in NGED EM Area (GSP Group _B)														
Effective from date	Import LLFC / DUoS Tariff ID	Import MPANs/MSIDs	Export LLFC / DUoS Tariff ID	Export MPANs/MSIDs	Name	Residual Charging Band	Import Super Red unit charge (p/kWh)	Import fixed charge (p/day)	Import capacity charge (p/kVA/day)	Import exceeded capacity charge (p/kVA/day)	Export Super Red unit charge (p/kWh)	Export fixed charge (p/day)	Export capacity charge (p/kVA/day)	Export exceeded capacity charge (p/kVA/day)

Southern Electric Power Distribution plc - Effective from 1 April 2027 - Final new or amended EHV line loss factors in NGED EM Area (GSP Group _B)														
Effective from date	Import LLFC / DUoS Tariff ID	Import MPANs/MSIDs	Export LLFC / DUoS Tariff ID	Export MPANs/MSIDs	Name	Residual Charging Band	Import LLF period 1	Import LLF period 2	Import LLF period 3	Import LLF period 4	Export LLF period 1	Export LLF period 2	Export LLF period 3	Export LLF period 4

**Annex 6 – Charges for New or Amended EHV Properties in “London Power Networks Area (GSP Group \_C)”**

Southern Electric Power Distribution plc - Effective from 1 April 2027 - Final new or amended EHV charges in UKPN LPN Area (GSP Group _C)														
Effective from date	Import LLFC / DUoS Tariff ID	Import MPANs/MSIDs	Export LLFC / DUoS Tariff ID	Export MPANs/MSIDs	Name	Residual Charging Band	Import Super Red unit charge (p/kWh)	Import fixed charge (p/day)	Import capacity charge (p/kVA/day)	Import exceeded capacity charge (p/kVA/day)	Export Super Red unit charge (p/kWh)	Export fixed charge (p/day)	Export capacity charge (p/kVA/day)	Export exceeded capacity charge (p/kVA/day)

Southern Electric Power Distribution plc - Effective from 1 April 2027 - Final new or amended EHV line loss factors in UKPN LPN Area (GSP Group _C)																
Effective from date	Import LLFC / DUoS Tariff ID	Import MPANs/MSIDs	Export LLFC / DUoS Tariff ID	Export MPANs/MSIDs	Name	Residual Charging Band	Import LLF period 1	Import LLF period 2	Import LLF period 3	Import LLF period 4	Import LLF period 5	Export LLF period 1	Export LLF period 2	Export LLF period 3	Export LLF period 4	Export LLF period 5

**Annex 6 – Charges for New or Amended EHV Properties in “SP Manweb Area (GSP Group \_D)”**

Southern Electric Power Distribution plc - Effective from 1 April 2027 - Final new or amended EHV charges in SP Manweb Area (GSP Group _D)														
Effective from date	Import LLFC / DUoS Tariff ID	Import MPANs/MSIDs	Export LLFC / DUoS Tariff ID	Export MPANs/MSIDs	Name	Residual Charging Band	Import Super Red unit charge (p/kWh)	Import fixed charge (p/day)	Import capacity charge (p/kVA/day)	Import exceeded capacity charge (p/kVA/day)	Export Super Red unit charge (p/kWh)	Export fixed charge (p/day)	Export capacity charge (p/kVA/day)	Export exceeded capacity charge (p/kVA/day)

Southern Electric Power Distribution plc - Effective from 1 April 2027 - Final new or amended EHV line loss factors in SP Manweb Area (GSP Group _D)														
Effective from date	Import LLFC / DUoS Tariff ID	Import MPANs/MSIDs	Export LLFC / DUoS Tariff ID	Export MPANs/MSIDs	Name	Residual Charging Band	Import LLF period 1	Import LLF period 2	Import LLF period 3	Import LLF period 4	Export LLF period 1	Export LLF period 2	Export LLF period 3	Export LLF period 4

**Annex 6 – Charges for New or Amended EHV Properties in “NGED West Midlands Area (GSP Group \_E)”**

Southern Electric Power Distribution plc - Effective from 1 April 2027 - Final new or amended EHV charges in NGED West Midlands Area (GSP Group _E)														
Effective from date	Import LLFC / DUoS Tariff ID	Import MPANs/MSIDs	Export LLFC / DUoS Tariff ID	Export MPANs/MSIDs	Name	Residual Charging Band	Import Super Red unit charge (p/kWh)	Import fixed charge (p/day)	Import capacity charge (p/kVA/day)	Import exceeded capacity charge (p/kVA/day)	Export Super Red unit charge (p/kWh)	Export fixed charge (p/day)	Export capacity charge (p/kVA/day)	Export exceeded capacity charge (p/kVA/day)

Southern Electric Power Distribution plc - Effective from 1 April 2027 - Final new or amended EHV line loss factors in NGED West Midlands Area (GSP Group _E)														
Effective from date	Import LLFC / DUoS Tariff ID	Import MPANs/MSIDs	Export LLFC / DUoS Tariff ID	Export MPANs/MSIDs	Name	Residual Charging Band	Import LLF period 1	Import LLF period 2	Import LLF period 3	Import LLF period 4	Export LLF period 1	Export LLF period 2	Export LLF period 3	Export LLF period 4

**Annex 6 – Charges for New or Amended EHV Properties in “Northern Powergrid (Northeast) Area (GSP Group \_F)”**

Southern Electric Power Distribution plc - Effective from 1 April 2027 - Final new or amended EHV charges in NPG Northeast Area (GSP Group _F)														
Effective from date	Import LLFC / DUoS Tariff ID	Import MPANs/MSIDs	Export LLFC / DUoS Tariff ID	Export MPANs/MSIDs	Name	Residual Charging Band	Import Super Red unit charge (p/kWh)	Import fixed charge (p/day)	Import capacity charge (p/kVA/day)	Import exceeded capacity charge (p/kVA/day)	Export Super Red unit charge (p/kWh)	Export fixed charge (p/day)	Export capacity charge (p/kVA/day)	Export exceeded capacity charge (p/kVA/day)

Southern Electric Power Distribution plc - Effective from 1 April 2027 - Final new or amended EHV line loss factors in NPG Northeast Area (GSP Group _F)														
Effective from date	Import LLFC / DUoS Tariff ID	Import MPANs/MSIDs	Export LLFC / DUoS Tariff ID	Export MPANs/MSIDs	Name	Residual Charging Band	Import LLF period 1	Import LLF period 2	Import LLF period 3	Import LLF period 4	Export LLF period 1	Export LLF period 2	Export LLF period 3	Export LLF period 4

**Annex 6 – Charges for New or Amended EHV Properties in “SP Electricity North West Area (GSP Group \_G)”**

Southern Electric Power Distribution plc - Effective from 1 April 2027 - Final new or amended EHV charges in SP Electricity North West Area (GSP Group _G)														
Effective from date	Import LLFC / DUoS Tariff ID	Import MPANs/MSIDs	Export LLFC / DUoS Tariff ID	Export MPANs/MSIDs	Name	Residual Charging Band	Import Super Red unit charge (p/kWh)	Import fixed charge (p/day)	Import capacity charge (p/kVA/day)	Import exceeded capacity charge (p/kVA/day)	Export Super Red unit charge (p/kWh)	Export fixed charge (p/day)	Export capacity charge (p/kVA/day)	Export exceeded capacity charge (p/kVA/day)

Southern Electric Power Distribution plc - Effective from 1 April 2027 - Final new or amended EHV line loss factors in SP Electricity North West Area (GSP Group _G)														
Effective from date	Import LLFC / DUoS Tariff ID	Import MPANs/MSIDs	Export LLFC / DUoS Tariff ID	Export MPANs/MSIDs	Name	Residual Charging Band	Import LLF period 1	Import LLF period 2	Import LLF period 3	Import LLF period 4	Export LLF period 1	Export LLF period 2	Export LLF period 3	Export LLF period 4

**Annex 6 – Charges for New or Amended EHV Properties in “South Eastern Power Networks Area (GSP Group \_J)”**

Southern Electric Power Distribution plc - Effective from 1 April 2027 - Final new or amended EHV charges in UKPN SPN Area (GSP Group _J)														
Effective from date	Import LLFC / DUoS Tariff ID	Import MPANs/MSIDs	Export LLFC / DUoS Tariff ID	Export MPANs/MSIDs	Name	Residual Charging Band	Import Super Red unit charge (p/kWh)	Import fixed charge (p/day)	Import capacity charge (p/kVA/day)	Import exceeded capacity charge (p/kVA/day)	Export Super Red unit charge (p/kWh)	Export fixed charge (p/day)	Export capacity charge (p/kVA/day)	Export exceeded capacity charge (p/kVA/day)

Southern Electric Power Distribution plc - Effective from 1 April 2027 - Final new or amended EHV line loss factors in UKPN SPN Area (GSP Group _J)																
Effective from date	Import LLFC / DUoS Tariff ID	Import MPANs/MSIDs	Export LLFC / DUoS Tariff ID	Export MPANs/MSIDs	Name	Residual Charging Band	Import LLF period 1	Import LLF period 2	Import LLF period 3	Import LLF period 4	Import LLF period 5	Export LLF period 1	Export LLF period 2	Export LLF period 3	Export LLF period 4	Export LLF period 5

**Annex 6 – Charges for New or Amended EHV Properties in “NGED South Wales Area (GSP Group \_K)”**

Southern Electric Power Distribution plc - Effective from 1 April 2027 - Final new or amended EHV charges in NGED South Wales Area (GSP Group _K)														
Effective from date	Import LLFC / DUoS Tariff ID	Import MPANs/MSIDs	Export LLFC / DUoS Tariff ID	Export MPANs/MSIDs	Name	Residual Charging Band	Import Super Red unit charge (p/kWh)	Import fixed charge (p/day)	Import capacity charge (p/kVA/day)	Import exceeded capacity charge (p/kVA/day)	Export Super Red unit charge (p/kWh)	Export fixed charge (p/day)	Export capacity charge (p/kVA/day)	Export exceeded capacity charge (p/kVA/day)

Southern Electric Power Distribution plc - Effective from 1 April 2027 - Final new or amended EHV line loss factors in NGED South Wales Area (GSP Group _K)														
Effective from date	Import LLFC / DUoS Tariff ID	Import MPANs/MSIDs	Export LLFC / DUoS Tariff ID	Export MPANs/MSIDs	Name	Residual Charging Band	Import LLF period 1	Import LLF period 2	Import LLF period 3	Import LLF period 4	Export LLF period 1	Export LLF period 2	Export LLF period 3	Export LLF period 4

**Annex 6 – Charges for New or Amended EHV Properties in “NGED South West Area (GSP Group \_L)”**

Southern Electric Power Distribution plc - Effective from 1 April 2027 - Final new or amended EHV charges in NGED South West Area (GSP Group _L)														
Effective from date	Import LLFC / DUoS Tariff ID	Import MPANs/MSIDs	Export LLFC / DUoS Tariff ID	Export MPANs/MSIDs	Name	Residual Charging Band	Import Super Red unit charge (p/kWh)	Import fixed charge (p/day)	Import capacity charge (p/kVA/day)	Import exceeded capacity charge (p/kVA/day)	Export Super Red unit charge (p/kWh)	Export fixed charge (p/day)	Export capacity charge (p/kVA/day)	Export exceeded capacity charge (p/kVA/day)

Southern Electric Power Distribution plc - Effective from 1 April 2027 - Final new or amended EHV line loss factors in NGED South West Area (GSP Group _L)														
Effective from date	Import LLFC / DUoS Tariff ID	Import MPANs/MSIDs	Export LLFC / DUoS Tariff ID	Export MPANs/MSIDs	Name	Residual Charging Band	Import LLF period 1	Import LLF period 2	Import LLF period 3	Import LLF period 4	Export LLF period 1	Export LLF period 2	Export LLF period 3	Export LLF period 4

**Annex 6 – Charges for New or Amended EHV Properties in “Northern Powergrid (Yorkshire) Area (GSP Group \_M)”**

Southern Electric Power Distribution plc - Effective from 1 April 2027 - Final new or amended EHV charges in NPG Yorkshire Area (GSP Group _M)														
Effective from date	Import LLFC / DUoS Tariff ID	Import MPANs/MSIDs	Export LLFC / DUoS Tariff ID	Export MPANs/MSIDs	Name	Residual Charging Band	Import Super Red unit charge (p/kWh)	Import fixed charge (p/day)	Import capacity charge (p/kVA/day)	Import exceeded capacity charge (p/kVA/day)	Export Super Red unit charge (p/kWh)	Export fixed charge (p/day)	Export capacity charge (p/kVA/day)	Export exceeded capacity charge (p/kVA/day)

Southern Electric Power Distribution plc - Effective from 1 April 2027 - Final new or amended EHV line loss factors in NPG Yorkshire Area (GSP Group _M)														
Effective from date	Import LLFC / DUoS Tariff ID	Import MPANs/MSIDs	Export LLFC / DUoS Tariff ID	Export MPANs/MSIDs	Name	Residual Charging Band	Import LLF period 1	Import LLF period 2	Import LLF period 3	Import LLF period 4	Export LLF period 1	Export LLF period 2	Export LLF period 3	Export LLF period 4

**Annex 7 – Supplier of last Resort and Eligible Bad Debt Pass-Through Costs in “Eastern Power Networks Area (GSP Group \_A)”**

**Southern Electric Power Distribution plc - Effective from 1 April 2027 - Final Supplier of Last Resort and Eligible Bad Debt Pass-Through Costs in UKPN EPN Area (GSP Group \_A)**

Tariff name	Open LLFCs / DUoS Tariff IDs / LDNO unique billing identifier	PCs	Supplier of Last Resort Fixed charge adder* p/MPAN/day	Eligible Bad Debt Fixed charge adder** p/MPAN/day
Domestic Aggregated or CT with Residual	167, 201-202, 258, 269, 301-302, 495, AA0	0, 1, 2	0.00	0.00
Non-Domestic Aggregated or CT No Residual	A10, A15, A20, A30, A35, A40, A45, A65, A70, A75, A85, A90, R75, AA1	0, 3, 4, 5-8		0.00
Non-Domestic Aggregated or CT Band 1	A11, A16, A21, A31, A36, A41, A46, A66, A71, A76, A86, A91, R76, AA2	0, 3, 4, 5-8		0.00
Non-Domestic Aggregated or CT Band 2	A12, A17, A22, A32, A37, A42, A47, A67, A72, A77, A87, A92, R77, AA3	0, 3, 4, 5-8		0.00
Non-Domestic Aggregated or CT Band 3	A13, A18, A23, A33, A38, A43, A48, A68, A73, A78, A88, A93, R78, AA4	0, 3, 4, 5-8		0.00
Non-Domestic Aggregated or CT Band 4	A14, A19, A24, A34, A39, A44, A49, A69, A74, A79, A89, A94, R79, AA5	0, 3, 4, 5-8		0.00
LV Site Specific No Residual	A05, A50, A60	0		0.00
LV Site Specific Band 1	A06, A51, A61	0		0.00
LV Site Specific Band 2	A07, A52, A62	0		0.00
LV Site Specific Band 3	A08, A53, A63	0		0.00
LV Site Specific Band 4	A09, A54, A64	0		0.00
LV Sub Site Specific No Residual	A95	0		0.00
LV Sub Site Specific Band 1	A96	0		0.00
LV Sub Site Specific Band 2	A97	0		0.00
LV Sub Site Specific Band 3	A98	0		0.00
LV Sub Site Specific Band 4	A99	0		0.00
HV Site Specific No Residual	A25, A55, A80	0		0.00
HV Site Specific Band 1	A26, A56, A81	0		0.00
HV Site Specific Band 2	A27, A57, A82	0		0.00
HV Site Specific Band 3	A28, A58, A83	0		0.00

Tariff name	Open LLCs / DUoS Tariff IDs / LDNO unique billing identifier	PCs	Supplier of Last Resort Fixed charge adder* p/MPAN/day	Eligible Bad Debt Fixed charge adder** p/MPAN/day
HV Site Specific Band 4	A29, A59, A84	0		0.00
LDNO LV: Domestic Aggregated or CT with Residual		0, 1, 2	0.00	0.00
LDNO LV: Non-Domestic Aggregated or CT No Residual		0, 3, 4, 5-8		0.00
LDNO LV: Non-Domestic Aggregated or CT Band 1		0, 3, 4, 5-8		0.00
LDNO LV: Non-Domestic Aggregated or CT Band 2		0, 3, 4, 5-8		0.00
LDNO LV: Non-Domestic Aggregated or CT Band 3		0, 3, 4, 5-8		0.00
LDNO LV: Non-Domestic Aggregated or CT Band 4		0, 3, 4, 5-8		0.00
LDNO LV: LV Site Specific No Residual		0		0.00
LDNO LV: LV Site Specific Band 1		0		0.00
LDNO LV: LV Site Specific Band 2		0		0.00
LDNO LV: LV Site Specific Band 3		0		0.00
LDNO LV: LV Site Specific Band 4		0		0.00
LDNO HV: Domestic Aggregated or CT with Residual		0, 1, 2	0.00	0.00
LDNO HV: Non-Domestic Aggregated or CT No Residual		0, 3, 4, 5-8		0.00
LDNO HV: Non-Domestic Aggregated or CT Band 1		0, 3, 4, 5-8		0.00
LDNO HV: Non-Domestic Aggregated or CT Band 2		0, 3, 4, 5-8		0.00
LDNO HV: Non-Domestic Aggregated or CT Band 3		0, 3, 4, 5-8		0.00
LDNO HV: Non-Domestic Aggregated or CT Band 4		0, 3, 4, 5-8		0.00
LDNO HV: LV Site Specific No Residual		0		0.00
LDNO HV: LV Site Specific Band 1		0		0.00
LDNO HV: LV Site Specific Band 2		0		0.00
LDNO HV: LV Site Specific Band 3		0		0.00
LDNO HV: LV Site Specific Band 4		0		0.00
LDNO HV: LV Sub Site Specific No Residual		0		0.00
LDNO HV: LV Sub Site Specific Band 1		0		0.00
LDNO HV: LV Sub Site Specific Band 2		0		0.00
LDNO HV: LV Sub Site Specific Band 3		0		0.00

Tariff name	Open LLFCs / DUoS Tariff IDs / LDNO unique billing identifier	PCs	Supplier of Last Resort Fixed charge adder* p/MPAN/day	Eligible Bad Debt Fixed charge adder** p/MPAN/day
LDNO HV: LV Sub Site Specific Band 4		0		0.00
LDNO HV: HV Site Specific No Residual		0		0.00
LDNO HV: HV Site Specific Band 1		0		0.00
LDNO HV: HV Site Specific Band 2		0		0.00
LDNO HV: HV Site Specific Band 3		0		0.00
LDNO HV: HV Site Specific Band 4		0		0.00
LDNO HVplus: Domestic Aggregated or CT with Residual		0, 1, 2	0.00	0.00
LDNO HVplus: Non-Domestic Aggregated or CT No Residual		0, 3, 4, 5-8		0.00
LDNO HVplus: Non-Domestic Aggregated or CT Band 1		0, 3, 4, 5-8		0.00
LDNO HVplus: Non-Domestic Aggregated or CT Band 2		0, 3, 4, 5-8		0.00
LDNO HVplus: Non-Domestic Aggregated or CT Band 3		0, 3, 4, 5-8		0.00
LDNO HVplus: Non-Domestic Aggregated or CT Band 4		0, 3, 4, 5-8		0.00
LDNO HVplus: LV Site Specific No Residual		0		0.00
LDNO HVplus: LV Site Specific Band 1		0		0.00
LDNO HVplus: LV Site Specific Band 2		0		0.00
LDNO HVplus: LV Site Specific Band 3		0		0.00
LDNO HVplus: LV Site Specific Band 4		0		0.00
LDNO HVplus: LV Sub Site Specific No Residual		0		0.00
LDNO HVplus: LV Sub Site Specific Band 1		0		0.00
LDNO HVplus: LV Sub Site Specific Band 2		0		0.00
LDNO HVplus: LV Sub Site Specific Band 3		0		0.00
LDNO HVplus: LV Sub Site Specific Band 4		0		0.00
LDNO HVplus: HV Site Specific No Residual		0		0.00
LDNO HVplus: HV Site Specific Band 1		0		0.00
LDNO HVplus: HV Site Specific Band 2		0		0.00
LDNO HVplus: HV Site Specific Band 3		0		0.00
LDNO HVplus: HV Site Specific Band 4		0		0.00
LDNO EHV: Domestic Aggregated or CT with Residual		0, 1, 2	0.00	0.00
LDNO EHV: Non-Domestic Aggregated or CT No Residual		0, 3, 4, 5-8		0.00

Tariff name	Open LLCs / DUoS Tariff IDs / LDNO unique billing identifier	PCs	Supplier of Last Resort Fixed charge adder* p/MPAN/day	Eligible Bad Debt Fixed charge adder** p/MPAN/day
LDNO EHV: Non-Domestic Aggregated or CT Band 1		0, 3, 4, 5-8		0.00
LDNO EHV: Non-Domestic Aggregated or CT Band 2		0, 3, 4, 5-8		0.00
LDNO EHV: Non-Domestic Aggregated or CT Band 3		0, 3, 4, 5-8		0.00
LDNO EHV: Non-Domestic Aggregated or CT Band 4		0, 3, 4, 5-8		0.00
LDNO EHV: LV Site Specific No Residual		0		0.00
LDNO EHV: LV Site Specific Band 1		0		0.00
LDNO EHV: LV Site Specific Band 2		0		0.00
LDNO EHV: LV Site Specific Band 3		0		0.00
LDNO EHV: LV Site Specific Band 4		0		0.00
LDNO EHV: LV Sub Site Specific No Residual		0		0.00
LDNO EHV: LV Sub Site Specific Band 1		0		0.00
LDNO EHV: LV Sub Site Specific Band 2		0		0.00
LDNO EHV: LV Sub Site Specific Band 3		0		0.00
LDNO EHV: LV Sub Site Specific Band 4		0		0.00
LDNO EHV: HV Site Specific No Residual		0		0.00
LDNO EHV: HV Site Specific Band 1		0		0.00
LDNO EHV: HV Site Specific Band 2		0		0.00
LDNO EHV: HV Site Specific Band 3		0		0.00
LDNO EHV: HV Site Specific Band 4		0		0.00
LDNO 132kV/EHV: Domestic Aggregated or CT with Residual		0, 1, 2	0.00	0.00
LDNO 132kV/EHV: Non-Domestic Aggregated or CT No Residual		0, 3, 4, 5-8		0.00
LDNO 132kV/EHV: Non-Domestic Aggregated or CT Band 1		0, 3, 4, 5-8		0.00
LDNO 132kV/EHV: Non-Domestic Aggregated or CT Band 2		0, 3, 4, 5-8		0.00
LDNO 132kV/EHV: Non-Domestic Aggregated or CT Band 3		0, 3, 4, 5-8		0.00
LDNO 132kV/EHV: Non-Domestic Aggregated or CT Band 4		0, 3, 4, 5-8		0.00
LDNO 132kV/EHV: LV Site Specific No Residual		0		0.00
LDNO 132kV/EHV: LV Site Specific Band 1		0		0.00
LDNO 132kV/EHV: LV Site Specific Band 2		0		0.00

Tariff name	Open LFCs / DUoS Tariff IDs / LDNO unique billing identifier	PCs	Supplier of Last Resort Fixed charge adder* p/MPAN/day	Eligible Bad Debt Fixed charge adder** p/MPAN/day
LDNO 132kV/EHV: LV Site Specific Band 3		0		0.00
LDNO 132kV/EHV: LV Site Specific Band 4		0		0.00
LDNO 132kV/EHV: LV Sub Site Specific No Residual		0		0.00
LDNO 132kV/EHV: LV Sub Site Specific Band 1		0		0.00
LDNO 132kV/EHV: LV Sub Site Specific Band 2		0		0.00
LDNO 132kV/EHV: LV Sub Site Specific Band 3		0		0.00
LDNO 132kV/EHV: LV Sub Site Specific Band 4		0		0.00
LDNO 132kV/EHV: HV Site Specific No Residual		0		0.00
LDNO 132kV/EHV: HV Site Specific Band 1		0		0.00
LDNO 132kV/EHV: HV Site Specific Band 2		0		0.00
LDNO 132kV/EHV: HV Site Specific Band 3		0		0.00
LDNO 132kV/EHV: HV Site Specific Band 4		0		0.00
LDNO 132kV: Domestic Aggregated or CT with Residual		0, 1, 2	0.00	0.00
LDNO 132kV: Non-Domestic Aggregated or CT No Residual		0, 3, 4, 5-8		0.00
LDNO 132kV: Non-Domestic Aggregated or CT Band 1		0, 3, 4, 5-8		0.00
LDNO 132kV: Non-Domestic Aggregated or CT Band 2		0, 3, 4, 5-8		0.00
LDNO 132kV: Non-Domestic Aggregated or CT Band 3		0, 3, 4, 5-8		0.00
LDNO 132kV: Non-Domestic Aggregated or CT Band 4		0, 3, 4, 5-8		0.00
LDNO 132kV: LV Site Specific No Residual		0		0.00
LDNO 132kV: LV Site Specific Band 1		0		0.00
LDNO 132kV: LV Site Specific Band 2		0		0.00
LDNO 132kV: LV Site Specific Band 3		0		0.00
LDNO 132kV: LV Site Specific Band 4		0		0.00
LDNO 132kV: LV Sub Site Specific No Residual		0		0.00
LDNO 132kV: LV Sub Site Specific Band 1		0		0.00
LDNO 132kV: LV Sub Site Specific Band 2		0		0.00
LDNO 132kV: LV Sub Site Specific Band 3		0		0.00
LDNO 132kV: LV Sub Site Specific Band 4		0		0.00
LDNO 132kV: HV Site Specific No Residual		0		0.00
LDNO 132kV: HV Site Specific Band 1		0		0.00
LDNO 132kV: HV Site Specific Band 2		0		0.00

Tariff name	Open LLFCs / DUoS Tariff IDs / LDNO unique billing identifier	PCs	Supplier of Last Resort Fixed charge adder* p/MPAN/day	Eligible Bad Debt Fixed charge adder** p/MPAN/day
LDNO 132kV: HV Site Specific Band 3		0		0.00
LDNO 132kV: HV Site Specific Band 4		0		0.00
LDNO 0000: Domestic Aggregated or CT with Residual		0, 1, 2	0.00	0.00
LDNO 0000: Non-Domestic Aggregated or CT No Residual		0, 3, 4, 5-8		0.00
LDNO 0000: Non-Domestic Aggregated or CT Band 1		0, 3, 4, 5-8		0.00
LDNO 0000: Non-Domestic Aggregated or CT Band 2		0, 3, 4, 5-8		0.00
LDNO 0000: Non-Domestic Aggregated or CT Band 3		0, 3, 4, 5-8		0.00
LDNO 0000: Non-Domestic Aggregated or CT Band 4		0, 3, 4, 5-8		0.00
LDNO 0000: LV Site Specific No Residual		0		0.00
LDNO 0000: LV Site Specific Band 1		0		0.00
LDNO 0000: LV Site Specific Band 2		0		0.00
LDNO 0000: LV Site Specific Band 3		0		0.00
LDNO 0000: LV Site Specific Band 4		0		0.00
LDNO 0000: LV Sub Site Specific No Residual		0		0.00
LDNO 0000: LV Sub Site Specific Band 1		0		0.00
LDNO 0000: LV Sub Site Specific Band 2		0		0.00
LDNO 0000: LV Sub Site Specific Band 3		0		0.00
LDNO 0000: LV Sub Site Specific Band 4		0		0.00
LDNO 0000: HV Site Specific No Residual		0		0.00
LDNO 0000: HV Site Specific Band 1		0		0.00
LDNO 0000: HV Site Specific Band 2		0		0.00
LDNO 0000: HV Site Specific Band 3		0		0.00
LDNO 0000: HV Site Specific Band 4		0		0.00

## Annex 7 – Supplier of last Resort and Eligible Bad Debt Pass-Through Costs in “NGED East Midlands Area (GSP Group \_B)”

### Southern Electric Power Distribution plc - Effective from 1 April 2027 - Final Supplier of Last Resort and Eligible Bad Debt Pass-Through Costs in NGED EM Area (GSP Group \_B)

Tariff name	Open LLFCs / DUoS Tariff IDs / LDNO unique billing identifier	PCs	Supplier of Last Resort Fixed charge adder* p/MPAN/day	Eligible Bad Debt Fixed charge adder** p/MPAN/day
Domestic Aggregated or CT with Residual	169, 279-280, 311-312, 461-462, 497, BA0	0, 1, 2	0.00	0.00
Non-Domestic Aggregated or CT No Residual	B05, B10, B15, B35, B40, B45, B55, B60, B70, B75, B80, B85, BA1	0, 3, 4, 5-8		0.00
Non-Domestic Aggregated or CT Band 1	B06, B11, B16, B36, B41, B46, B56, B61, B71, B76, B81, B86, BA2	0, 3, 4, 5-8		0.00
Non-Domestic Aggregated or CT Band 2	B07, B12, B17, B37, B42, B47, B57, B62, B72, B77, B82, B87, BA3	0, 3, 4, 5-8		0.00
Non-Domestic Aggregated or CT Band 3	B08, B13, B18, B38, B43, B48, B58, B63, B73, B78, B83, B88, BA4	0, 3, 4, 5-8		0.00
Non-Domestic Aggregated or CT Band 4	B09, B14, B19, B39, B44, B49, B59, B64, B74, B79, B84, B89, BA5	0, 3, 4, 5-8		0.00
LV Site Specific No Residual	B20, B30	0		0.00
LV Site Specific Band 1	B21, B31	0		0.00
LV Site Specific Band 2	B22, B32	0		0.00
LV Site Specific Band 3	B23, B33	0		0.00
LV Site Specific Band 4	B24, B34	0		0.00
LV Sub Site Specific No Residual	B65	0		0.00
LV Sub Site Specific Band 1	B66	0		0.00
LV Sub Site Specific Band 2	B67	0		0.00
LV Sub Site Specific Band 3	B68	0		0.00
LV Sub Site Specific Band 4	B69	0		0.00
HV Site Specific No Residual	B25, B50	0		0.00
HV Site Specific Band 1	B26, B51	0		0.00
HV Site Specific Band 2	B27, B52	0		0.00

Tariff name	Open LLFCs / DUoS Tariff IDs / LDNO unique billing identifier	PCs	Supplier of Last Resort Fixed charge adder* p/MPAN/day	Eligible Bad Debt Fixed charge adder** p/MPAN/day
HV Site Specific Band 3	B28, B53	0		0.00
HV Site Specific Band 4	B29, B54	0		0.00
LDNO LV: Domestic Aggregated or CT with Residual		0, 1, 2	0.00	0.00
LDNO LV: Non-Domestic Aggregated or CT No Residual		0, 3, 4, 5-8		0.00
LDNO LV: Non-Domestic Aggregated or CT Band 1		0, 3, 4, 5-8		0.00
LDNO LV: Non-Domestic Aggregated or CT Band 2		0, 3, 4, 5-8		0.00
LDNO LV: Non-Domestic Aggregated or CT Band 3		0, 3, 4, 5-8		0.00
LDNO LV: Non-Domestic Aggregated or CT Band 4		0, 3, 4, 5-8		0.00
LDNO LV: LV Site Specific No Residual		0		0.00
LDNO LV: LV Site Specific Band 1		0		0.00
LDNO LV: LV Site Specific Band 2		0		0.00
LDNO LV: LV Site Specific Band 3		0		0.00
LDNO LV: LV Site Specific Band 4		0		0.00
LDNO HV: Domestic Aggregated or CT with Residual		0, 1, 2	0.00	0.00
LDNO HV: Non-Domestic Aggregated or CT No Residual		0, 3, 4, 5-8		0.00
LDNO HV: Non-Domestic Aggregated or CT Band 1		0, 3, 4, 5-8		0.00
LDNO HV: Non-Domestic Aggregated or CT Band 2		0, 3, 4, 5-8		0.00
LDNO HV: Non-Domestic Aggregated or CT Band 3		0, 3, 4, 5-8		0.00
LDNO HV: Non-Domestic Aggregated or CT Band 4		0, 3, 4, 5-8		0.00
LDNO HV: LV Site Specific No Residual		0		0.00
LDNO HV: LV Site Specific Band 1		0		0.00
LDNO HV: LV Site Specific Band 2		0		0.00
LDNO HV: LV Site Specific Band 3		0		0.00
LDNO HV: LV Site Specific Band 4		0		0.00
LDNO HV: LV Sub Site Specific No Residual		0		0.00
LDNO HV: LV Sub Site Specific Band 1		0		0.00
LDNO HV: LV Sub Site Specific Band 2		0		0.00

Tariff name	Open LLCs / DUoS Tariff IDs / LDNO unique billing identifier	PCs	Supplier of Last Resort Fixed charge adder* p/MPAN/day	Eligible Bad Debt Fixed charge adder** p/MPAN/day
LDNO HV: LV Sub Site Specific Band 3		0		0.00
LDNO HV: LV Sub Site Specific Band 4		0		0.00
LDNO HV: HV Site Specific No Residual		0		0.00
LDNO HV: HV Site Specific Band 1		0		0.00
LDNO HV: HV Site Specific Band 2		0		0.00
LDNO HV: HV Site Specific Band 3		0		0.00
LDNO HV: HV Site Specific Band 4		0		0.00
LDNO HVplus: Domestic Aggregated or CT with Residual		0, 1, 2	0.00	0.00
LDNO HVplus: Non-Domestic Aggregated or CT No Residual		0, 3, 4, 5-8		0.00
LDNO HVplus: Non-Domestic Aggregated or CT Band 1		0, 3, 4, 5-8		0.00
LDNO HVplus: Non-Domestic Aggregated or CT Band 2		0, 3, 4, 5-8		0.00
LDNO HVplus: Non-Domestic Aggregated or CT Band 3		0, 3, 4, 5-8		0.00
LDNO HVplus: Non-Domestic Aggregated or CT Band 4		0, 3, 4, 5-8		0.00
LDNO HVplus: LV Site Specific No Residual		0		0.00
LDNO HVplus: LV Site Specific Band 1		0		0.00
LDNO HVplus: LV Site Specific Band 2		0		0.00
LDNO HVplus: LV Site Specific Band 3		0		0.00
LDNO HVplus: LV Site Specific Band 4		0		0.00
LDNO HVplus: LV Sub Site Specific No Residual		0		0.00
LDNO HVplus: LV Sub Site Specific Band 1		0		0.00
LDNO HVplus: LV Sub Site Specific Band 2		0		0.00
LDNO HVplus: LV Sub Site Specific Band 3		0		0.00
LDNO HVplus: LV Sub Site Specific Band 4		0		0.00
LDNO HVplus: HV Site Specific No Residual		0		0.00
LDNO HVplus: HV Site Specific Band 1		0		0.00
LDNO HVplus: HV Site Specific Band 2		0		0.00
LDNO HVplus: HV Site Specific Band 3		0		0.00
LDNO HVplus: HV Site Specific Band 4		0		0.00
LDNO EHV: Domestic Aggregated or CT with Residual		0, 1, 2	0.00	0.00
LDNO EHV: Non-Domestic Aggregated or CT No Residual		0, 3, 4, 5-8		0.00

Tariff name	Open LLCs / DUoS Tariff IDs / LDNO unique billing identifier	PCs	Supplier of Last Resort Fixed charge adder* p/MPAN/day	Eligible Bad Debt Fixed charge adder** p/MPAN/day
LDNO EHV: Non-Domestic Aggregated or CT Band 1		0, 3, 4, 5-8		0.00
LDNO EHV: Non-Domestic Aggregated or CT Band 2		0, 3, 4, 5-8		0.00
LDNO EHV: Non-Domestic Aggregated or CT Band 3		0, 3, 4, 5-8		0.00
LDNO EHV: Non-Domestic Aggregated or CT Band 4		0, 3, 4, 5-8		0.00
LDNO EHV: LV Site Specific No Residual		0		0.00
LDNO EHV: LV Site Specific Band 1		0		0.00
LDNO EHV: LV Site Specific Band 2		0		0.00
LDNO EHV: LV Site Specific Band 3		0		0.00
LDNO EHV: LV Site Specific Band 4		0		0.00
LDNO EHV: LV Sub Site Specific No Residual		0		0.00
LDNO EHV: LV Sub Site Specific Band 1		0		0.00
LDNO EHV: LV Sub Site Specific Band 2		0		0.00
LDNO EHV: LV Sub Site Specific Band 3		0		0.00
LDNO EHV: LV Sub Site Specific Band 4		0		0.00
LDNO EHV: HV Site Specific No Residual		0		0.00
LDNO EHV: HV Site Specific Band 1		0		0.00
LDNO EHV: HV Site Specific Band 2		0		0.00
LDNO EHV: HV Site Specific Band 3		0		0.00
LDNO EHV: HV Site Specific Band 4		0		0.00
LDNO 132kV/EHV: Domestic Aggregated or CT with Residual		0, 1, 2	0.00	0.00
LDNO 132kV/EHV: Non-Domestic Aggregated or CT No Residual		0, 3, 4, 5-8		0.00
LDNO 132kV/EHV: Non-Domestic Aggregated or CT Band 1		0, 3, 4, 5-8		0.00
LDNO 132kV/EHV: Non-Domestic Aggregated or CT Band 2		0, 3, 4, 5-8		0.00
LDNO 132kV/EHV: Non-Domestic Aggregated or CT Band 3		0, 3, 4, 5-8		0.00
LDNO 132kV/EHV: Non-Domestic Aggregated or CT Band 4		0, 3, 4, 5-8		0.00
LDNO 132kV/EHV: LV Site Specific No Residual		0		0.00
LDNO 132kV/EHV: LV Site Specific Band 1		0		0.00
LDNO 132kV/EHV: LV Site Specific Band 2		0		0.00

Tariff name	Open LFCs / DUoS Tariff IDs / LDNO unique billing identifier	PCs	Supplier of Last Resort Fixed charge adder* p/MPAN/day	Eligible Bad Debt Fixed charge adder** p/MPAN/day
LDNO 132kV/EHV: LV Site Specific Band 3		0		0.00
LDNO 132kV/EHV: LV Site Specific Band 4		0		0.00
LDNO 132kV/EHV: LV Sub Site Specific No Residual		0		0.00
LDNO 132kV/EHV: LV Sub Site Specific Band 1		0		0.00
LDNO 132kV/EHV: LV Sub Site Specific Band 2		0		0.00
LDNO 132kV/EHV: LV Sub Site Specific Band 3		0		0.00
LDNO 132kV/EHV: LV Sub Site Specific Band 4		0		0.00
LDNO 132kV/EHV: HV Site Specific No Residual		0		0.00
LDNO 132kV/EHV: HV Site Specific Band 1		0		0.00
LDNO 132kV/EHV: HV Site Specific Band 2		0		0.00
LDNO 132kV/EHV: HV Site Specific Band 3		0		0.00
LDNO 132kV/EHV: HV Site Specific Band 4		0		0.00
LDNO 132kV: Domestic Aggregated or CT with Residual		0, 1, 2	0.00	0.00
LDNO 132kV: Non-Domestic Aggregated or CT No Residual		0, 3, 4, 5-8		0.00
LDNO 132kV: Non-Domestic Aggregated or CT Band 1		0, 3, 4, 5-8		0.00
LDNO 132kV: Non-Domestic Aggregated or CT Band 2		0, 3, 4, 5-8		0.00
LDNO 132kV: Non-Domestic Aggregated or CT Band 3		0, 3, 4, 5-8		0.00
LDNO 132kV: Non-Domestic Aggregated or CT Band 4		0, 3, 4, 5-8		0.00
LDNO 132kV: LV Site Specific No Residual		0		0.00
LDNO 132kV: LV Site Specific Band 1		0		0.00
LDNO 132kV: LV Site Specific Band 2		0		0.00
LDNO 132kV: LV Site Specific Band 3		0		0.00
LDNO 132kV: LV Site Specific Band 4		0		0.00
LDNO 132kV: LV Sub Site Specific No Residual		0		0.00
LDNO 132kV: LV Sub Site Specific Band 1		0		0.00
LDNO 132kV: LV Sub Site Specific Band 2		0		0.00
LDNO 132kV: LV Sub Site Specific Band 3		0		0.00
LDNO 132kV: LV Sub Site Specific Band 4		0		0.00
LDNO 132kV: HV Site Specific No Residual		0		0.00
LDNO 132kV: HV Site Specific Band 1		0		0.00
LDNO 132kV: HV Site Specific Band 2		0		0.00

Tariff name	Open LLFCs / DUoS Tariff IDs / LDNO unique billing identifier	PCs	Supplier of Last Resort Fixed charge adder* p/MPAN/day	Eligible Bad Debt Fixed charge adder** p/MPAN/day
LDNO 132kV: HV Site Specific Band 3		0		0.00
LDNO 132kV: HV Site Specific Band 4		0		0.00
LDNO 0000: Domestic Aggregated or CT with Residual		0, 1, 2	0.00	0.00
LDNO 0000: Non-Domestic Aggregated or CT No Residual		0, 3, 4, 5-8		0.00
LDNO 0000: Non-Domestic Aggregated or CT Band 1		0, 3, 4, 5-8		0.00
LDNO 0000: Non-Domestic Aggregated or CT Band 2		0, 3, 4, 5-8		0.00
LDNO 0000: Non-Domestic Aggregated or CT Band 3		0, 3, 4, 5-8		0.00
LDNO 0000: Non-Domestic Aggregated or CT Band 4		0, 3, 4, 5-8		0.00
LDNO 0000: LV Site Specific No Residual		0		0.00
LDNO 0000: LV Site Specific Band 1		0		0.00
LDNO 0000: LV Site Specific Band 2		0		0.00
LDNO 0000: LV Site Specific Band 3		0		0.00
LDNO 0000: LV Site Specific Band 4		0		0.00
LDNO 0000: LV Sub Site Specific No Residual		0		0.00
LDNO 0000: LV Sub Site Specific Band 1		0		0.00
LDNO 0000: LV Sub Site Specific Band 2		0		0.00
LDNO 0000: LV Sub Site Specific Band 3		0		0.00
LDNO 0000: LV Sub Site Specific Band 4		0		0.00
LDNO 0000: HV Site Specific No Residual		0		0.00
LDNO 0000: HV Site Specific Band 1		0		0.00
LDNO 0000: HV Site Specific Band 2		0		0.00
LDNO 0000: HV Site Specific Band 3		0		0.00
LDNO 0000: HV Site Specific Band 4		0		0.00

## Annex 7 – Supplier of last Resort and Eligible Bad Debt Pass-Through Costs in “London Power Networks Area (GSP Group \_C)”

### Southern Electric Power Distribution plc - Effective from 1 April 2027 - Final Supplier of Last Resort and Eligible Bad Debt Pass-Through Costs in UKPN LPN Area (GSP Group \_C)

Tariff name	Open LLFCs / DUoS Tariff IDs / LDNO unique billing identifier	PCs	Supplier of Last Resort Fixed charge adder* p/MPAN/day	Eligible Bad Debt Fixed charge adder** p/MPAN/day
Domestic Aggregated or CT with Residual	171, 191-192, 221-222, 321-322, 417-418, 506, 508, CA0	0, 1, 2	0.00	0.00
Non-Domestic Aggregated or CT No Residual	C05, C10, C20, C30, C35, C40, C50, C60, C65, C70, C80, C85, C90, C95, R20, R25, R30, R35, CA1	0, 3, 4, 5-8		0.00
Non-Domestic Aggregated or CT Band 1	C06, C11, C21, C31, C36, C41, C51, C61, C66, C71, C81, C86, C91, C96, R21, R26, R31, R36, CA2	0, 3, 4, 5-8		0.00
Non-Domestic Aggregated or CT Band 2	C07, C12, C22, C32, C37, C42, C52, C62, C67, C72, C82, C87, C92, C97, R22, R27, R32, R37, CA3	0, 3, 4, 5-8		0.00
Non-Domestic Aggregated or CT Band 3	C08, C13, C23, C33, C38, C43, C53, C63, C68, C73, C83, C88, C93, C98, R23, R28, R33, R38, CA4	0, 3, 4, 5-8		0.00
Non-Domestic Aggregated or CT Band 4	C09, C14, C24, C34, C39, C44, C54, C64, C69, C74, C84, C89, C94, C99, R24, R29, R34, R39, CA5	0, 3, 4, 5-8		0.00
LV Site Specific No Residual	C15, C25, C55, R00	0		0.00
LV Site Specific Band 1	C16, C26, C56, R01	0		0.00
LV Site Specific Band 2	C17, C27, C57, R02	0		0.00
LV Site Specific Band 3	C18, C28, C58, R03	0		0.00
LV Site Specific Band 4	C19, C29, C59, R04	0		0.00
LV Sub Site Specific No Residual	R10, R15	0		0.00
LV Sub Site Specific Band 1	R11, R16	0		0.00
LV Sub Site Specific Band 2	R12, R17	0		0.00
LV Sub Site Specific Band 3	R13, R18	0		0.00

Tariff name	Open LLFCs / DUoS Tariff IDs / LDNO unique billing identifier	PCs	Supplier of Last Resort Fixed charge adder* p/MPAN/day	Eligible Bad Debt Fixed charge adder** p/MPAN/day
LV Sub Site Specific Band 4	R14, R19	0		0.00
HV Site Specific No Residual	C45, C75, R05	0		0.00
HV Site Specific Band 1	C46, C76, R06	0		0.00
HV Site Specific Band 2	C47, C77, R07	0		0.00
HV Site Specific Band 3	C48, C78, R08	0		0.00
HV Site Specific Band 4	C49, C79, R09	0		0.00
LDNO LV: Domestic Aggregated or CT with Residual		0, 1, 2	0.00	0.00
LDNO LV: Non-Domestic Aggregated or CT No Residual		0, 3, 4, 5-8		0.00
LDNO LV: Non-Domestic Aggregated or CT Band 1		0, 3, 4, 5-8		0.00
LDNO LV: Non-Domestic Aggregated or CT Band 2		0, 3, 4, 5-8		0.00
LDNO LV: Non-Domestic Aggregated or CT Band 3		0, 3, 4, 5-8		0.00
LDNO LV: Non-Domestic Aggregated or CT Band 4		0, 3, 4, 5-8		0.00
LDNO LV: LV Site Specific No Residual		0		0.00
LDNO LV: LV Site Specific Band 1		0		0.00
LDNO LV: LV Site Specific Band 2		0		0.00
LDNO LV: LV Site Specific Band 3		0		0.00
LDNO LV: LV Site Specific Band 4		0		0.00
LDNO HV: Domestic Aggregated or CT with Residual		0, 1, 2	0.00	0.00
LDNO HV: Non-Domestic Aggregated or CT No Residual		0, 3, 4, 5-8		0.00
LDNO HV: Non-Domestic Aggregated or CT Band 1		0, 3, 4, 5-8		0.00
LDNO HV: Non-Domestic Aggregated or CT Band 2		0, 3, 4, 5-8		0.00
LDNO HV: Non-Domestic Aggregated or CT Band 3		0, 3, 4, 5-8		0.00
LDNO HV: Non-Domestic Aggregated or CT Band 4		0, 3, 4, 5-8		0.00
LDNO HV: LV Site Specific No Residual		0		0.00
LDNO HV: LV Site Specific Band 1		0		0.00
LDNO HV: LV Site Specific Band 2		0		0.00
LDNO HV: LV Site Specific Band 3		0		0.00

Tariff name	Open LFCs / DUoS Tariff IDs / LDNO unique billing identifier	PCs	Supplier of Last Resort Fixed charge adder* p/MPAN/day	Eligible Bad Debt Fixed charge adder** p/MPAN/day
LDNO HV: LV Site Specific Band 4		0		0.00
LDNO HV: LV Sub Site Specific No Residual		0		0.00
LDNO HV: LV Sub Site Specific Band 1		0		0.00
LDNO HV: LV Sub Site Specific Band 2		0		0.00
LDNO HV: LV Sub Site Specific Band 3		0		0.00
LDNO HV: LV Sub Site Specific Band 4		0		0.00
LDNO HV: HV Site Specific No Residual		0		0.00
LDNO HV: HV Site Specific Band 1		0		0.00
LDNO HV: HV Site Specific Band 2		0		0.00
LDNO HV: HV Site Specific Band 3		0		0.00
LDNO HV: HV Site Specific Band 4		0		0.00
LDNO HVplus: Domestic Aggregated or CT with Residual		0, 1, 2	0.00	0.00
LDNO HVplus: Non-Domestic Aggregated or CT No Residual		0, 3, 4, 5-8		0.00
LDNO HVplus: Non-Domestic Aggregated or CT Band 1		0, 3, 4, 5-8		0.00
LDNO HVplus: Non-Domestic Aggregated or CT Band 2		0, 3, 4, 5-8		0.00
LDNO HVplus: Non-Domestic Aggregated or CT Band 3		0, 3, 4, 5-8		0.00
LDNO HVplus: Non-Domestic Aggregated or CT Band 4		0, 3, 4, 5-8		0.00
LDNO HVplus: LV Site Specific No Residual		0		0.00
LDNO HVplus: LV Site Specific Band 1		0		0.00
LDNO HVplus: LV Site Specific Band 2		0		0.00
LDNO HVplus: LV Site Specific Band 3		0		0.00
LDNO HVplus: LV Site Specific Band 4		0		0.00
LDNO HVplus: LV Sub Site Specific No Residual		0		0.00
LDNO HVplus: LV Sub Site Specific Band 1		0		0.00
LDNO HVplus: LV Sub Site Specific Band 2		0		0.00
LDNO HVplus: LV Sub Site Specific Band 3		0		0.00
LDNO HVplus: LV Sub Site Specific Band 4		0		0.00
LDNO HVplus: HV Site Specific No Residual		0		0.00
LDNO HVplus: HV Site Specific Band 1		0		0.00
LDNO HVplus: HV Site Specific Band 2		0		0.00
LDNO HVplus: HV Site Specific Band 3		0		0.00

Tariff name	Open LLFCs / DUoS Tariff IDs / LDNO unique billing identifier	PCs	Supplier of Last Resort Fixed charge adder* p/MPAN/day	Eligible Bad Debt Fixed charge adder** p/MPAN/day
LDNO HVplus: HV Site Specific Band 4		0		0.00
LDNO EHV: Domestic Aggregated or CT with Residual		0, 1, 2	0.00	0.00
LDNO EHV: Non-Domestic Aggregated or CT No Residual		0, 3, 4, 5-8		0.00
LDNO EHV: Non-Domestic Aggregated or CT Band 1		0, 3, 4, 5-8		0.00
LDNO EHV: Non-Domestic Aggregated or CT Band 2		0, 3, 4, 5-8		0.00
LDNO EHV: Non-Domestic Aggregated or CT Band 3		0, 3, 4, 5-8		0.00
LDNO EHV: Non-Domestic Aggregated or CT Band 4		0, 3, 4, 5-8		0.00
LDNO EHV: LV Site Specific No Residual		0		0.00
LDNO EHV: LV Site Specific Band 1		0		0.00
LDNO EHV: LV Site Specific Band 2		0		0.00
LDNO EHV: LV Site Specific Band 3		0		0.00
LDNO EHV: LV Site Specific Band 4		0		0.00
LDNO EHV: LV Sub Site Specific No Residual		0		0.00
LDNO EHV: LV Sub Site Specific Band 1		0		0.00
LDNO EHV: LV Sub Site Specific Band 2		0		0.00
LDNO EHV: LV Sub Site Specific Band 3		0		0.00
LDNO EHV: LV Sub Site Specific Band 4		0		0.00
LDNO EHV: HV Site Specific No Residual		0		0.00
LDNO EHV: HV Site Specific Band 1		0		0.00
LDNO EHV: HV Site Specific Band 2		0		0.00
LDNO EHV: HV Site Specific Band 3		0		0.00
LDNO EHV: HV Site Specific Band 4		0		0.00
LDNO 132kV/EHV: Domestic Aggregated or CT with Residual		0, 1, 2	0.00	0.00
LDNO 132kV/EHV: Non-Domestic Aggregated or CT No Residual		0, 3, 4, 5-8		0.00
LDNO 132kV/EHV: Non-Domestic Aggregated or CT Band 1		0, 3, 4, 5-8		0.00
LDNO 132kV/EHV: Non-Domestic Aggregated or CT Band 2		0, 3, 4, 5-8		0.00
LDNO 132kV/EHV: Non-Domestic Aggregated or CT Band 3		0, 3, 4, 5-8		0.00

Tariff name	Open LLFCs / DUoS Tariff IDs / LDNO unique billing identifier	PCs	Supplier of Last Resort Fixed charge adder* p/MPAN/day	Eligible Bad Debt Fixed charge adder** p/MPAN/day
LDNO 132kV/EHV: Non-Domestic Aggregated or CT Band 4		0, 3, 4, 5-8		0.00
LDNO 132kV/EHV: LV Site Specific No Residual		0		0.00
LDNO 132kV/EHV: LV Site Specific Band 1		0		0.00
LDNO 132kV/EHV: LV Site Specific Band 2		0		0.00
LDNO 132kV/EHV: LV Site Specific Band 3		0		0.00
LDNO 132kV/EHV: LV Site Specific Band 4		0		0.00
LDNO 132kV/EHV: LV Sub Site Specific No Residual		0		0.00
LDNO 132kV/EHV: LV Sub Site Specific Band 1		0		0.00
LDNO 132kV/EHV: LV Sub Site Specific Band 2		0		0.00
LDNO 132kV/EHV: LV Sub Site Specific Band 3		0		0.00
LDNO 132kV/EHV: LV Sub Site Specific Band 4		0		0.00
LDNO 132kV/EHV: HV Site Specific No Residual		0		0.00
LDNO 132kV/EHV: HV Site Specific Band 1		0		0.00
LDNO 132kV/EHV: HV Site Specific Band 2		0		0.00
LDNO 132kV/EHV: HV Site Specific Band 3		0		0.00
LDNO 132kV/EHV: HV Site Specific Band 4		0		0.00
LDNO 132kV: Domestic Aggregated or CT with Residual		0, 1, 2	0.00	0.00
LDNO 132kV: Non-Domestic Aggregated or CT No Residual		0, 3, 4, 5-8		0.00
LDNO 132kV: Non-Domestic Aggregated or CT Band 1		0, 3, 4, 5-8		0.00
LDNO 132kV: Non-Domestic Aggregated or CT Band 2		0, 3, 4, 5-8		0.00
LDNO 132kV: Non-Domestic Aggregated or CT Band 3		0, 3, 4, 5-8		0.00
LDNO 132kV: Non-Domestic Aggregated or CT Band 4		0, 3, 4, 5-8		0.00
LDNO 132kV: LV Site Specific No Residual		0		0.00
LDNO 132kV: LV Site Specific Band 1		0		0.00
LDNO 132kV: LV Site Specific Band 2		0		0.00
LDNO 132kV: LV Site Specific Band 3		0		0.00
LDNO 132kV: LV Site Specific Band 4		0		0.00
LDNO 132kV: LV Sub Site Specific No Residual		0		0.00
LDNO 132kV: LV Sub Site Specific Band 1		0		0.00
LDNO 132kV: LV Sub Site Specific Band 2		0		0.00

Tariff name	Open LLFCs / DUoS Tariff IDs / LDNO unique billing identifier	PCs	Supplier of Last Resort Fixed charge adder* p/MPAN/day	Eligible Bad Debt Fixed charge adder** p/MPAN/day
LDNO 132kV: LV Sub Site Specific Band 3		0		0.00
LDNO 132kV: LV Sub Site Specific Band 4		0		0.00
LDNO 132kV: HV Site Specific No Residual		0		0.00
LDNO 132kV: HV Site Specific Band 1		0		0.00
LDNO 132kV: HV Site Specific Band 2		0		0.00
LDNO 132kV: HV Site Specific Band 3		0		0.00
LDNO 132kV: HV Site Specific Band 4		0		0.00
LDNO 0000: Domestic Aggregated or CT with Residual		0, 1, 2	0.00	0.00
LDNO 0000: Non-Domestic Aggregated or CT No Residual		0, 3, 4, 5-8		0.00
LDNO 0000: Non-Domestic Aggregated or CT Band 1		0, 3, 4, 5-8		0.00
LDNO 0000: Non-Domestic Aggregated or CT Band 2		0, 3, 4, 5-8		0.00
LDNO 0000: Non-Domestic Aggregated or CT Band 3		0, 3, 4, 5-8		0.00
LDNO 0000: Non-Domestic Aggregated or CT Band 4		0, 3, 4, 5-8		0.00
LDNO 0000: LV Site Specific No Residual		0		0.00
LDNO 0000: LV Site Specific Band 1		0		0.00
LDNO 0000: LV Site Specific Band 2		0		0.00
LDNO 0000: LV Site Specific Band 3		0		0.00
LDNO 0000: LV Site Specific Band 4		0		0.00
LDNO 0000: LV Sub Site Specific No Residual		0		0.00
LDNO 0000: LV Sub Site Specific Band 1		0		0.00
LDNO 0000: LV Sub Site Specific Band 2		0		0.00
LDNO 0000: LV Sub Site Specific Band 3		0		0.00
LDNO 0000: LV Sub Site Specific Band 4		0		0.00
LDNO 0000: HV Site Specific No Residual		0		0.00
LDNO 0000: HV Site Specific Band 1		0		0.00
LDNO 0000: HV Site Specific Band 2		0		0.00
LDNO 0000: HV Site Specific Band 3		0		0.00
LDNO 0000: HV Site Specific Band 4		0		0.00

## Annex 7 – Supplier of last Resort and Eligible Bad Debt Pass-Through Costs in “SP Manweb Area (GSP Group \_D)”

### Southern Electric Power Distribution plc - Effective from 1 April 2027 - Final Supplier of Last Resort and Eligible Bad Debt Pass-Through Costs in SP Manweb Area (GSP Group \_D)

Tariff name	Open LLFCs / DUoS Tariff IDs / LDNO unique billing identifier	PCs	Supplier of Last Resort Fixed charge adder* p/MPAN/day	Eligible Bad Debt Fixed charge adder** p/MPAN/day
Domestic Aggregated or CT with Residual	173, 331-332, DA0	0, 1, 2	0.00	0.00
Non-Domestic Aggregated or CT No Residual	D45, D15, D20, D25, D35, DA1	0, 3, 4, 5-8		0.00
Non-Domestic Aggregated or CT Band 1	D46, D16, D21, D26, D36, DA2	0, 3, 4, 5-8		0.00
Non-Domestic Aggregated or CT Band 2	D47, D17, D22, D27, D37, DA3	0, 3, 4, 5-8		0.00
Non-Domestic Aggregated or CT Band 3	D48, D18, D23, D28, D38, DA4	0, 3, 4, 5-8		0.00
Non-Domestic Aggregated or CT Band 4	D49, D19, D24, D29, D39, DA5	0, 3, 4, 5-8		0.00
LV Site Specific No Residual	D10	0		0.00
LV Site Specific Band 1	D11	0		0.00
LV Site Specific Band 2	D12	0		0.00
LV Site Specific Band 3	D13	0		0.00
LV Site Specific Band 4	D14	0		0.00
LV Sub Site Specific No Residual	D40	0		0.00
LV Sub Site Specific Band 1	D41	0		0.00
LV Sub Site Specific Band 2	D42	0		0.00
LV Sub Site Specific Band 3	D43	0		0.00
LV Sub Site Specific Band 4	D44	0		0.00
HV Site Specific No Residual	D05, D30	0		0.00
HV Site Specific Band 1	D06, D31	0		0.00
HV Site Specific Band 2	D07, D32	0		0.00
HV Site Specific Band 3	D08, D33	0		0.00
HV Site Specific Band 4	D09, D34	0		0.00
LDNO LV: Domestic Aggregated or CT with Residual		0, 1, 2	0.00	0.00
LDNO LV: Non-Domestic Aggregated or CT No Residual		0, 3, 4, 5-8		0.00

Tariff name	Open LLFCs / DUoS Tariff IDs / LDNO unique billing identifier	PCs	Supplier of Last Resort Fixed charge adder* p/MPAN/day	Eligible Bad Debt Fixed charge adder** p/MPAN/day
LDNO LV: Non-Domestic Aggregated or CT Band 1		0, 3, 4, 5-8		0.00
LDNO LV: Non-Domestic Aggregated or CT Band 2		0, 3, 4, 5-8		0.00
LDNO LV: Non-Domestic Aggregated or CT Band 3		0, 3, 4, 5-8		0.00
LDNO LV: Non-Domestic Aggregated or CT Band 4		0, 3, 4, 5-8		0.00
LDNO LV: LV Site Specific No Residual		0		0.00
LDNO LV: LV Site Specific Band 1		0		0.00
LDNO LV: LV Site Specific Band 2		0		0.00
LDNO LV: LV Site Specific Band 3		0		0.00
LDNO LV: LV Site Specific Band 4		0		0.00
LDNO HV: Domestic Aggregated or CT with Residual		0, 1, 2	0.00	0.00
LDNO HV: Non-Domestic Aggregated or CT No Residual		0, 3, 4, 5-8		0.00
LDNO HV: Non-Domestic Aggregated or CT Band 1		0, 3, 4, 5-8		0.00
LDNO HV: Non-Domestic Aggregated or CT Band 2		0, 3, 4, 5-8		0.00
LDNO HV: Non-Domestic Aggregated or CT Band 3		0, 3, 4, 5-8		0.00
LDNO HV: Non-Domestic Aggregated or CT Band 4		0, 3, 4, 5-8		0.00
LDNO HV: LV Site Specific No Residual		0		0.00
LDNO HV: LV Site Specific Band 1		0		0.00
LDNO HV: LV Site Specific Band 2		0		0.00
LDNO HV: LV Site Specific Band 3		0		0.00
LDNO HV: LV Site Specific Band 4		0		0.00
LDNO HV: LV Sub Site Specific No Residual		0		0.00
LDNO HV: LV Sub Site Specific Band 1		0		0.00
LDNO HV: LV Sub Site Specific Band 2		0		0.00
LDNO HV: LV Sub Site Specific Band 3		0		0.00
LDNO HV: LV Sub Site Specific Band 4		0		0.00
LDNO HV: HV Site Specific No Residual		0		0.00
LDNO HV: HV Site Specific Band 1		0		0.00
LDNO HV: HV Site Specific Band 2		0		0.00

Tariff name	Open LLFCs / DUoS Tariff IDs / LDNO unique billing identifier	PCs	Supplier of Last Resort Fixed charge adder* p/MPAN/day	Eligible Bad Debt Fixed charge adder** p/MPAN/day
LDNO HV: HV Site Specific Band 3		0		0.00
LDNO HV: HV Site Specific Band 4		0		0.00
LDNO HVplus: Domestic Aggregated or CT with Residual		0, 1, 2	0.00	0.00
LDNO HVplus: Non-Domestic Aggregated or CT No Residual		0, 3, 4, 5-8		0.00
LDNO HVplus: Non-Domestic Aggregated or CT Band 1		0, 3, 4, 5-8		0.00
LDNO HVplus: Non-Domestic Aggregated or CT Band 2		0, 3, 4, 5-8		0.00
LDNO HVplus: Non-Domestic Aggregated or CT Band 3		0, 3, 4, 5-8		0.00
LDNO HVplus: Non-Domestic Aggregated or CT Band 4		0, 3, 4, 5-8		0.00
LDNO HVplus: LV Site Specific No Residual		0		0.00
LDNO HVplus: LV Site Specific Band 1		0		0.00
LDNO HVplus: LV Site Specific Band 2		0		0.00
LDNO HVplus: LV Site Specific Band 3		0		0.00
LDNO HVplus: LV Site Specific Band 4		0		0.00
LDNO HVplus: LV Sub Site Specific No Residual		0		0.00
LDNO HVplus: LV Sub Site Specific Band 1		0		0.00
LDNO HVplus: LV Sub Site Specific Band 2		0		0.00
LDNO HVplus: LV Sub Site Specific Band 3		0		0.00
LDNO HVplus: LV Sub Site Specific Band 4		0		0.00
LDNO HVplus: HV Site Specific No Residual		0		0.00
LDNO HVplus: HV Site Specific Band 1		0		0.00
LDNO HVplus: HV Site Specific Band 2		0		0.00
LDNO HVplus: HV Site Specific Band 3		0		0.00
LDNO HVplus: HV Site Specific Band 4		0		0.00
LDNO EHV: Domestic Aggregated or CT with Residual		0, 1, 2	0.00	0.00
LDNO EHV: Non-Domestic Aggregated or CT No Residual		0, 3, 4, 5-8		0.00
LDNO EHV: Non-Domestic Aggregated or CT Band 1		0, 3, 4, 5-8		0.00
LDNO EHV: Non-Domestic Aggregated or CT Band 2		0, 3, 4, 5-8		0.00
LDNO EHV: Non-Domestic Aggregated or CT Band 3		0, 3, 4, 5-8		0.00

Tariff name	Open LLFCs / DUoS Tariff IDs / LDNO unique billing identifier	PCs	Supplier of Last Resort Fixed charge adder* p/MPAN/day	Eligible Bad Debt Fixed charge adder** p/MPAN/day
LDNO EHV: Non-Domestic Aggregated or CT Band 4		0, 3, 4, 5-8		0.00
LDNO EHV: LV Site Specific No Residual		0		0.00
LDNO EHV: LV Site Specific Band 1		0		0.00
LDNO EHV: LV Site Specific Band 2		0		0.00
LDNO EHV: LV Site Specific Band 3		0		0.00
LDNO EHV: LV Site Specific Band 4		0		0.00
LDNO EHV: LV Sub Site Specific No Residual		0		0.00
LDNO EHV: LV Sub Site Specific Band 1		0		0.00
LDNO EHV: LV Sub Site Specific Band 2		0		0.00
LDNO EHV: LV Sub Site Specific Band 3		0		0.00
LDNO EHV: LV Sub Site Specific Band 4		0		0.00
LDNO EHV: HV Site Specific No Residual		0		0.00
LDNO EHV: HV Site Specific Band 1		0		0.00
LDNO EHV: HV Site Specific Band 2		0		0.00
LDNO EHV: HV Site Specific Band 3		0		0.00
LDNO EHV: HV Site Specific Band 4		0		0.00
LDNO 132kV/EHV: Domestic Aggregated or CT with Residual		0, 1, 2	0.00	0.00
LDNO 132kV/EHV: Non-Domestic Aggregated or CT No Residual		0, 3, 4, 5-8		0.00
LDNO 132kV/EHV: Non-Domestic Aggregated or CT Band 1		0, 3, 4, 5-8		0.00
LDNO 132kV/EHV: Non-Domestic Aggregated or CT Band 2		0, 3, 4, 5-8		0.00
LDNO 132kV/EHV: Non-Domestic Aggregated or CT Band 3		0, 3, 4, 5-8		0.00
LDNO 132kV/EHV: Non-Domestic Aggregated or CT Band 4		0, 3, 4, 5-8		0.00
LDNO 132kV/EHV: LV Site Specific No Residual		0		0.00
LDNO 132kV/EHV: LV Site Specific Band 1		0		0.00
LDNO 132kV/EHV: LV Site Specific Band 2		0		0.00
LDNO 132kV/EHV: LV Site Specific Band 3		0		0.00
LDNO 132kV/EHV: LV Site Specific Band 4		0		0.00
LDNO 132kV/EHV: LV Sub Site Specific No Residual		0		0.00
LDNO 132kV/EHV: LV Sub Site Specific Band 1		0		0.00
LDNO 132kV/EHV: LV Sub Site Specific Band 2		0		0.00

Tariff name	Open LLFCs / DUoS Tariff IDs / LDNO unique billing identifier	PCs	Supplier of Last Resort Fixed charge adder* p/MPAN/day	Eligible Bad Debt Fixed charge adder** p/MPAN/day
LDNO 132kV/EHV: LV Sub Site Specific Band 3		0		0.00
LDNO 132kV/EHV: LV Sub Site Specific Band 4		0		0.00
LDNO 132kV/EHV: HV Site Specific No Residual		0		0.00
LDNO 132kV/EHV: HV Site Specific Band 1		0		0.00
LDNO 132kV/EHV: HV Site Specific Band 2		0		0.00
LDNO 132kV/EHV: HV Site Specific Band 3		0		0.00
LDNO 132kV/EHV: HV Site Specific Band 4		0		0.00
LDNO 132kV: Domestic Aggregated or CT with Residual		0, 1, 2	0.00	0.00
LDNO 132kV: Non-Domestic Aggregated or CT No Residual		0, 3, 4, 5-8		0.00
LDNO 132kV: Non-Domestic Aggregated or CT Band 1		0, 3, 4, 5-8		0.00
LDNO 132kV: Non-Domestic Aggregated or CT Band 2		0, 3, 4, 5-8		0.00
LDNO 132kV: Non-Domestic Aggregated or CT Band 3		0, 3, 4, 5-8		0.00
LDNO 132kV: Non-Domestic Aggregated or CT Band 4		0, 3, 4, 5-8		0.00
LDNO 132kV: LV Site Specific No Residual		0		0.00
LDNO 132kV: LV Site Specific Band 1		0		0.00
LDNO 132kV: LV Site Specific Band 2		0		0.00
LDNO 132kV: LV Site Specific Band 3		0		0.00
LDNO 132kV: LV Site Specific Band 4		0		0.00
LDNO 132kV: LV Sub Site Specific No Residual		0		0.00
LDNO 132kV: LV Sub Site Specific Band 1		0		0.00
LDNO 132kV: LV Sub Site Specific Band 2		0		0.00
LDNO 132kV: LV Sub Site Specific Band 3		0		0.00
LDNO 132kV: LV Sub Site Specific Band 4		0		0.00
LDNO 132kV: HV Site Specific No Residual		0		0.00
LDNO 132kV: HV Site Specific Band 1		0		0.00
LDNO 132kV: HV Site Specific Band 2		0		0.00
LDNO 132kV: HV Site Specific Band 3		0		0.00
LDNO 132kV: HV Site Specific Band 4		0		0.00
LDNO 0000: Domestic Aggregated or CT with Residual		0, 1, 2	0.00	0.00
LDNO 0000: Non-Domestic Aggregated or CT No Residual		0, 3, 4, 5-8		0.00

Tariff name	Open LLFCs / DUoS Tariff IDs / LDNO unique billing identifier	PCs	Supplier of Last Resort Fixed charge adder* p/MPAN/day	Eligible Bad Debt Fixed charge adder** p/MPAN/day
LDNO 0000: Non-Domestic Aggregated or CT Band 1		0, 3, 4, 5-8		0.00
LDNO 0000: Non-Domestic Aggregated or CT Band 2		0, 3, 4, 5-8		0.00
LDNO 0000: Non-Domestic Aggregated or CT Band 3		0, 3, 4, 5-8		0.00
LDNO 0000: Non-Domestic Aggregated or CT Band 4		0, 3, 4, 5-8		0.00
LDNO 0000: LV Site Specific No Residual		0		0.00
LDNO 0000: LV Site Specific Band 1		0		0.00
LDNO 0000: LV Site Specific Band 2		0		0.00
LDNO 0000: LV Site Specific Band 3		0		0.00
LDNO 0000: LV Site Specific Band 4		0		0.00
LDNO 0000: LV Sub Site Specific No Residual		0		0.00
LDNO 0000: LV Sub Site Specific Band 1		0		0.00
LDNO 0000: LV Sub Site Specific Band 2		0		0.00
LDNO 0000: LV Sub Site Specific Band 3		0		0.00
LDNO 0000: LV Sub Site Specific Band 4		0		0.00
LDNO 0000: HV Site Specific No Residual		0		0.00
LDNO 0000: HV Site Specific Band 1		0		0.00
LDNO 0000: HV Site Specific Band 2		0		0.00
LDNO 0000: HV Site Specific Band 3		0		0.00
LDNO 0000: HV Site Specific Band 4		0		0.00

## Annex 7 – Supplier of last Resort and Eligible Bad Debt Pass-Through Costs in “NGED West Midlands Area (GSP Group \_E)”

### Southern Electric Power Distribution plc - Effective from 1 April 2027 - Final Supplier of Last Resort and Eligible Bad Debt Pass-Through Costs in NGED West Midlands Area (GSP Group \_E)

Tariff name	Open LLFCs / DUoS Tariff IDs / LDNO unique billing identifier	PCs	Supplier of Last Resort Fixed charge adder* p/MPAN/day	Eligible Bad Debt Fixed charge adder** p/MPAN/day
Domestic Aggregated or CT with Residual	175, 341-342, EA0	0, 1, 2	0.00	0.00
Non-Domestic Aggregated or CT No Residual	E10, E15, E20, E30, E40, EA1	0, 3, 4, 5-8		0.00
Non-Domestic Aggregated or CT Band 1	E11, E16, E21, E31, E41, EA2	0, 3, 4, 5-8		0.00
Non-Domestic Aggregated or CT Band 2	E12, E17, E22, E32, E42, EA3	0, 3, 4, 5-8		0.00
Non-Domestic Aggregated or CT Band 3	E13, E18, E23, E33, E43, EA4	0, 3, 4, 5-8		0.00
Non-Domestic Aggregated or CT Band 4	E14, E19, E24, E34, E44, EA5	0, 3, 4, 5-8		0.00
LV Site Specific No Residual	E05	0		0.00
LV Site Specific Band 1	E06	0		0.00
LV Site Specific Band 2	E07	0		0.00
LV Site Specific Band 3	E08	0		0.00
LV Site Specific Band 4	E09	0		0.00
LV Sub Site Specific No Residual	E35	0		0.00
LV Sub Site Specific Band 1	E36	0		0.00
LV Sub Site Specific Band 2	E37	0		0.00
LV Sub Site Specific Band 3	E38	0		0.00
LV Sub Site Specific Band 4	E39	0		0.00
HV Site Specific No Residual	E25	0		0.00
HV Site Specific Band 1	E26	0		0.00
HV Site Specific Band 2	E27	0		0.00
HV Site Specific Band 3	E28	0		0.00
HV Site Specific Band 4	E29	0		0.00
LDNO LV: Domestic Aggregated or CT with Residual		0, 1, 2	0.00	0.00
LDNO LV: Non-Domestic Aggregated or CT No Residual		0, 3, 4, 5-8		0.00

Tariff name	Open LLFCs / DUoS Tariff IDs / LDNO unique billing identifier	PCs	Supplier of Last Resort Fixed charge adder* p/MPAN/day	Eligible Bad Debt Fixed charge adder** p/MPAN/day
LDNO LV: Non-Domestic Aggregated or CT Band 1		0, 3, 4, 5-8		0.00
LDNO LV: Non-Domestic Aggregated or CT Band 2		0, 3, 4, 5-8		0.00
LDNO LV: Non-Domestic Aggregated or CT Band 3		0, 3, 4, 5-8		0.00
LDNO LV: Non-Domestic Aggregated or CT Band 4		0, 3, 4, 5-8		0.00
LDNO LV: LV Site Specific No Residual		0		0.00
LDNO LV: LV Site Specific Band 1		0		0.00
LDNO LV: LV Site Specific Band 2		0		0.00
LDNO LV: LV Site Specific Band 3		0		0.00
LDNO LV: LV Site Specific Band 4		0		0.00
LDNO HV: Domestic Aggregated or CT with Residual		0, 1, 2	0.00	0.00
LDNO HV: Non-Domestic Aggregated or CT No Residual		0, 3, 4, 5-8		0.00
LDNO HV: Non-Domestic Aggregated or CT Band 1		0, 3, 4, 5-8		0.00
LDNO HV: Non-Domestic Aggregated or CT Band 2		0, 3, 4, 5-8		0.00
LDNO HV: Non-Domestic Aggregated or CT Band 3		0, 3, 4, 5-8		0.00
LDNO HV: Non-Domestic Aggregated or CT Band 4		0, 3, 4, 5-8		0.00
LDNO HV: LV Site Specific No Residual		0		0.00
LDNO HV: LV Site Specific Band 1		0		0.00
LDNO HV: LV Site Specific Band 2		0		0.00
LDNO HV: LV Site Specific Band 3		0		0.00
LDNO HV: LV Site Specific Band 4		0		0.00
LDNO HV: LV Sub Site Specific No Residual		0		0.00
LDNO HV: LV Sub Site Specific Band 1		0		0.00
LDNO HV: LV Sub Site Specific Band 2		0		0.00
LDNO HV: LV Sub Site Specific Band 3		0		0.00
LDNO HV: LV Sub Site Specific Band 4		0		0.00
LDNO HV: HV Site Specific No Residual		0		0.00
LDNO HV: HV Site Specific Band 1		0		0.00
LDNO HV: HV Site Specific Band 2		0		0.00

Tariff name	Open LLCs / DUoS Tariff IDs / LDNO unique billing identifier	PCs	Supplier of Last Resort Fixed charge adder* p/MPAN/day	Eligible Bad Debt Fixed charge adder** p/MPAN/day
LDNO HV: HV Site Specific Band 3		0		0.00
LDNO HV: HV Site Specific Band 4		0		0.00
LDNO HVplus: Domestic Aggregated or CT with Residual		0, 1, 2	0.00	0.00
LDNO HVplus: Non-Domestic Aggregated or CT No Residual		0, 3, 4, 5-8		0.00
LDNO HVplus: Non-Domestic Aggregated or CT Band 1		0, 3, 4, 5-8		0.00
LDNO HVplus: Non-Domestic Aggregated or CT Band 2		0, 3, 4, 5-8		0.00
LDNO HVplus: Non-Domestic Aggregated or CT Band 3		0, 3, 4, 5-8		0.00
LDNO HVplus: Non-Domestic Aggregated or CT Band 4		0, 3, 4, 5-8		0.00
LDNO HVplus: LV Site Specific No Residual		0		0.00
LDNO HVplus: LV Site Specific Band 1		0		0.00
LDNO HVplus: LV Site Specific Band 2		0		0.00
LDNO HVplus: LV Site Specific Band 3		0		0.00
LDNO HVplus: LV Site Specific Band 4		0		0.00
LDNO HVplus: LV Sub Site Specific No Residual		0		0.00
LDNO HVplus: LV Sub Site Specific Band 1		0		0.00
LDNO HVplus: LV Sub Site Specific Band 2		0		0.00
LDNO HVplus: LV Sub Site Specific Band 3		0		0.00
LDNO HVplus: LV Sub Site Specific Band 4		0		0.00
LDNO HVplus: HV Site Specific No Residual		0		0.00
LDNO HVplus: HV Site Specific Band 1		0		0.00
LDNO HVplus: HV Site Specific Band 2		0		0.00
LDNO HVplus: HV Site Specific Band 3		0		0.00
LDNO HVplus: HV Site Specific Band 4		0		0.00
LDNO EHV: Domestic Aggregated or CT with Residual		0, 1, 2	0.00	0.00
LDNO EHV: Non-Domestic Aggregated or CT No Residual		0, 3, 4, 5-8		0.00
LDNO EHV: Non-Domestic Aggregated or CT Band 1		0, 3, 4, 5-8		0.00
LDNO EHV: Non-Domestic Aggregated or CT Band 2		0, 3, 4, 5-8		0.00
LDNO EHV: Non-Domestic Aggregated or CT Band 3		0, 3, 4, 5-8		0.00

Tariff name	Open LLFCs / DUoS Tariff IDs / LDNO unique billing identifier	PCs	Supplier of Last Resort Fixed charge adder* p/MPAN/day	Eligible Bad Debt Fixed charge adder** p/MPAN/day
LDNO EHV: Non-Domestic Aggregated or CT Band 4		0, 3, 4, 5-8		0.00
LDNO EHV: LV Site Specific No Residual		0		0.00
LDNO EHV: LV Site Specific Band 1		0		0.00
LDNO EHV: LV Site Specific Band 2		0		0.00
LDNO EHV: LV Site Specific Band 3		0		0.00
LDNO EHV: LV Site Specific Band 4		0		0.00
LDNO EHV: LV Sub Site Specific No Residual		0		0.00
LDNO EHV: LV Sub Site Specific Band 1		0		0.00
LDNO EHV: LV Sub Site Specific Band 2		0		0.00
LDNO EHV: LV Sub Site Specific Band 3		0		0.00
LDNO EHV: LV Sub Site Specific Band 4		0		0.00
LDNO EHV: HV Site Specific No Residual		0		0.00
LDNO EHV: HV Site Specific Band 1		0		0.00
LDNO EHV: HV Site Specific Band 2		0		0.00
LDNO EHV: HV Site Specific Band 3		0		0.00
LDNO EHV: HV Site Specific Band 4		0		0.00
LDNO 132kV/EHV: Domestic Aggregated or CT with Residual		0, 1, 2	0.00	0.00
LDNO 132kV/EHV: Non-Domestic Aggregated or CT No Residual		0, 3, 4, 5-8		0.00
LDNO 132kV/EHV: Non-Domestic Aggregated or CT Band 1		0, 3, 4, 5-8		0.00
LDNO 132kV/EHV: Non-Domestic Aggregated or CT Band 2		0, 3, 4, 5-8		0.00
LDNO 132kV/EHV: Non-Domestic Aggregated or CT Band 3		0, 3, 4, 5-8		0.00
LDNO 132kV/EHV: Non-Domestic Aggregated or CT Band 4		0, 3, 4, 5-8		0.00
LDNO 132kV/EHV: LV Site Specific No Residual		0		0.00
LDNO 132kV/EHV: LV Site Specific Band 1		0		0.00
LDNO 132kV/EHV: LV Site Specific Band 2		0		0.00
LDNO 132kV/EHV: LV Site Specific Band 3		0		0.00
LDNO 132kV/EHV: LV Site Specific Band 4		0		0.00
LDNO 132kV/EHV: LV Sub Site Specific No Residual		0		0.00
LDNO 132kV/EHV: LV Sub Site Specific Band 1		0		0.00
LDNO 132kV/EHV: LV Sub Site Specific Band 2		0		0.00

Tariff name	Open LLFCs / DUoS Tariff IDs / LDNO unique billing identifier	PCs	Supplier of Last Resort Fixed charge adder* p/MPAN/day	Eligible Bad Debt Fixed charge adder** p/MPAN/day
LDNO 132kV/EHV: LV Sub Site Specific Band 3		0		0.00
LDNO 132kV/EHV: LV Sub Site Specific Band 4		0		0.00
LDNO 132kV/EHV: HV Site Specific No Residual		0		0.00
LDNO 132kV/EHV: HV Site Specific Band 1		0		0.00
LDNO 132kV/EHV: HV Site Specific Band 2		0		0.00
LDNO 132kV/EHV: HV Site Specific Band 3		0		0.00
LDNO 132kV/EHV: HV Site Specific Band 4		0		0.00
LDNO 132kV: Domestic Aggregated or CT with Residual		0, 1, 2	0.00	0.00
LDNO 132kV: Non-Domestic Aggregated or CT No Residual		0, 3, 4, 5-8		0.00
LDNO 132kV: Non-Domestic Aggregated or CT Band 1		0, 3, 4, 5-8		0.00
LDNO 132kV: Non-Domestic Aggregated or CT Band 2		0, 3, 4, 5-8		0.00
LDNO 132kV: Non-Domestic Aggregated or CT Band 3		0, 3, 4, 5-8		0.00
LDNO 132kV: Non-Domestic Aggregated or CT Band 4		0, 3, 4, 5-8		0.00
LDNO 132kV: LV Site Specific No Residual		0		0.00
LDNO 132kV: LV Site Specific Band 1		0		0.00
LDNO 132kV: LV Site Specific Band 2		0		0.00
LDNO 132kV: LV Site Specific Band 3		0		0.00
LDNO 132kV: LV Site Specific Band 4		0		0.00
LDNO 132kV: LV Sub Site Specific No Residual		0		0.00
LDNO 132kV: LV Sub Site Specific Band 1		0		0.00
LDNO 132kV: LV Sub Site Specific Band 2		0		0.00
LDNO 132kV: LV Sub Site Specific Band 3		0		0.00
LDNO 132kV: LV Sub Site Specific Band 4		0		0.00
LDNO 132kV: HV Site Specific No Residual		0		0.00
LDNO 132kV: HV Site Specific Band 1		0		0.00
LDNO 132kV: HV Site Specific Band 2		0		0.00
LDNO 132kV: HV Site Specific Band 3		0		0.00
LDNO 132kV: HV Site Specific Band 4		0		0.00
LDNO 0000: Domestic Aggregated or CT with Residual		0, 1, 2	0.00	0.00
LDNO 0000: Non-Domestic Aggregated or CT No Residual		0, 3, 4, 5-8		0.00

Tariff name	Open LLFCs / DUoS Tariff IDs / LDNO unique billing identifier	PCs	Supplier of Last Resort Fixed charge adder* p/MPAN/day	Eligible Bad Debt Fixed charge adder** p/MPAN/day
LDNO 0000: Non-Domestic Aggregated or CT Band 1		0, 3, 4, 5-8		0.00
LDNO 0000: Non-Domestic Aggregated or CT Band 2		0, 3, 4, 5-8		0.00
LDNO 0000: Non-Domestic Aggregated or CT Band 3		0, 3, 4, 5-8		0.00
LDNO 0000: Non-Domestic Aggregated or CT Band 4		0, 3, 4, 5-8		0.00
LDNO 0000: LV Site Specific No Residual		0		0.00
LDNO 0000: LV Site Specific Band 1		0		0.00
LDNO 0000: LV Site Specific Band 2		0		0.00
LDNO 0000: LV Site Specific Band 3		0		0.00
LDNO 0000: LV Site Specific Band 4		0		0.00
LDNO 0000: LV Sub Site Specific No Residual		0		0.00
LDNO 0000: LV Sub Site Specific Band 1		0		0.00
LDNO 0000: LV Sub Site Specific Band 2		0		0.00
LDNO 0000: LV Sub Site Specific Band 3		0		0.00
LDNO 0000: LV Sub Site Specific Band 4		0		0.00
LDNO 0000: HV Site Specific No Residual		0		0.00
LDNO 0000: HV Site Specific Band 1		0		0.00
LDNO 0000: HV Site Specific Band 2		0		0.00
LDNO 0000: HV Site Specific Band 3		0		0.00
LDNO 0000: HV Site Specific Band 4		0		0.00

**Annex 7 – Supplier of last Resort and Eligible Bad Debt Pass-Through Costs in “Northern Powergrid (Northeast) Area (GSP Group \_F)”**

**Southern Electric Power Distribution plc - Effective from 1 April 2027 - Final Supplier of Last Resort and Eligible Bad Debt Pass-Through Costs in NPG Northeast Area (GSP Group \_F)**

Tariff name	Open LLFCs / DUoS Tariff IDs / LDNO unique billing identifier	PCs	Supplier of Last Resort Fixed charge adder* p/MPAN/day	Eligible Bad Debt Fixed charge adder** p/MPAN/day
Domestic Aggregated or CT with Residual	177, 179, 251-252, 351-352, 428-429, 514, 751-752, FA3, SA0	0, 1, 2	0.00	0.00
Non-Domestic Aggregated or CT No Residual	F05, F15, F20, F25, F35, F45, F50, F55, F65, F70, F75, F80, F85, R40, S05, S15, S20, S25, S35, FA4, SA1	0, 3, 4, 5-8		0.00
Non-Domestic Aggregated or CT Band 1	F06, F16, F21, F26, F36, F46, F51, F56, F66, F71, F76, F81, F86, R41, S06, S16, S21, S26, S36, FA5, SA2	0, 3, 4, 5-8		0.00
Non-Domestic Aggregated or CT Band 2	F07, F17, F22, F27, F37, F47, F52, F57, F67, F72, F77, F82, F87, R42, S07, S17, S22, S27, S37, FA6, SA3	0, 3, 4, 5-8		0.00
Non-Domestic Aggregated or CT Band 3	F08, F18, F23, F28, F38, F48, F53, F58, F68, F73, F78, F83, F88, R43, S08, S18, S23, S28, S38, FA7, SA4	0, 3, 4, 5-8		0.00
Non-Domestic Aggregated or CT Band 4	F09, F19, F24, F29, F39, F49, F54, F59, F69, F74, F79, F84, F89, R44, S09, S19, S24, S29, S39, FA8, SA5	0, 3, 4, 5-8		0.00
LV Site Specific No Residual	F10, F40, F90, S10	0		0.00
LV Site Specific Band 1	F11, F41, F91, S11	0		0.00
LV Site Specific Band 2	F12, F42, F92, S12	0		0.00
LV Site Specific Band 3	F13, F43, F93, S13	0		0.00

Tariff name	Open LLFCs / DUoS Tariff IDs / LDNO unique billing identifier	PCs	Supplier of Last Resort Fixed charge adder* p/MPAN/day	Eligible Bad Debt Fixed charge adder** p/MPAN/day
LV Site Specific Band 4	F14, F44, F94, S14	0		0.00
LV Sub Site Specific No Residual	S00	0		0.00
LV Sub Site Specific Band 1	S01	0		0.00
LV Sub Site Specific Band 2	S02	0		0.00
LV Sub Site Specific Band 3	S03	0		0.00
LV Sub Site Specific Band 4	S04	0		0.00
HV Site Specific No Residual	F30, F60, F95, S30	0		0.00
HV Site Specific Band 1	F31, F61, F96, S31	0		0.00
HV Site Specific Band 2	F32, F62, F97, S32	0		0.00
HV Site Specific Band 3	F33, F63, F98, S33	0		0.00
HV Site Specific Band 4	F34, F64, F99, S34	0		0.00
LDNO LV: Domestic Aggregated or CT with Residual		0, 1, 2	0.00	0.00
LDNO LV: Non-Domestic Aggregated or CT No Residual		0, 3, 4, 5-8		0.00
LDNO LV: Non-Domestic Aggregated or CT Band 1		0, 3, 4, 5-8		0.00
LDNO LV: Non-Domestic Aggregated or CT Band 2		0, 3, 4, 5-8		0.00
LDNO LV: Non-Domestic Aggregated or CT Band 3		0, 3, 4, 5-8		0.00
LDNO LV: Non-Domestic Aggregated or CT Band 4		0, 3, 4, 5-8		0.00
LDNO LV: LV Site Specific No Residual		0		0.00
LDNO LV: LV Site Specific Band 1		0		0.00
LDNO LV: LV Site Specific Band 2		0		0.00
LDNO LV: LV Site Specific Band 3		0		0.00
LDNO LV: LV Site Specific Band 4		0		0.00
LDNO HV: Domestic Aggregated or CT with Residual		0, 1, 2	0.00	0.00
LDNO HV: Non-Domestic Aggregated or CT No Residual		0, 3, 4, 5-8		0.00
LDNO HV: Non-Domestic Aggregated or CT Band 1		0, 3, 4, 5-8		0.00
LDNO HV: Non-Domestic Aggregated or CT Band 2		0, 3, 4, 5-8		0.00
LDNO HV: Non-Domestic Aggregated or CT Band 3		0, 3, 4, 5-8		0.00

Tariff name	Open LLFCs / DUoS Tariff IDs / LDNO unique billing identifier	PCs	Supplier of Last Resort Fixed charge adder* p/MPAN/day	Eligible Bad Debt Fixed charge adder** p/MPAN/day
LDNO HV: Non-Domestic Aggregated or CT Band 4		0, 3, 4, 5-8		0.00
LDNO HV: LV Site Specific No Residual		0		0.00
LDNO HV: LV Site Specific Band 1		0		0.00
LDNO HV: LV Site Specific Band 2		0		0.00
LDNO HV: LV Site Specific Band 3		0		0.00
LDNO HV: LV Site Specific Band 4		0		0.00
LDNO HV: LV Sub Site Specific No Residual		0		0.00
LDNO HV: LV Sub Site Specific Band 1		0		0.00
LDNO HV: LV Sub Site Specific Band 2		0		0.00
LDNO HV: LV Sub Site Specific Band 3		0		0.00
LDNO HV: LV Sub Site Specific Band 4		0		0.00
LDNO HV: HV Site Specific No Residual		0		0.00
LDNO HV: HV Site Specific Band 1		0		0.00
LDNO HV: HV Site Specific Band 2		0		0.00
LDNO HV: HV Site Specific Band 3		0		0.00
LDNO HV: HV Site Specific Band 4		0		0.00
LDNO HVplus: Domestic Aggregated or CT with Residual		0, 1, 2	0.00	0.00
LDNO HVplus: Non-Domestic Aggregated or CT No Residual		0, 3, 4, 5-8		0.00
LDNO HVplus: Non-Domestic Aggregated or CT Band 1		0, 3, 4, 5-8		0.00
LDNO HVplus: Non-Domestic Aggregated or CT Band 2		0, 3, 4, 5-8		0.00
LDNO HVplus: Non-Domestic Aggregated or CT Band 3		0, 3, 4, 5-8		0.00
LDNO HVplus: Non-Domestic Aggregated or CT Band 4		0, 3, 4, 5-8		0.00
LDNO HVplus: LV Site Specific No Residual		0		0.00
LDNO HVplus: LV Site Specific Band 1		0		0.00
LDNO HVplus: LV Site Specific Band 2		0		0.00
LDNO HVplus: LV Site Specific Band 3		0		0.00
LDNO HVplus: LV Site Specific Band 4		0		0.00
LDNO HVplus: LV Sub Site Specific No Residual		0		0.00
LDNO HVplus: LV Sub Site Specific Band 1		0		0.00
LDNO HVplus: LV Sub Site Specific Band 2		0		0.00

Tariff name	Open LLFCs / DUoS Tariff IDs / LDNO unique billing identifier	PCs	Supplier of Last Resort Fixed charge adder* p/MPAN/day	Eligible Bad Debt Fixed charge adder** p/MPAN/day
LDNO HVplus: LV Sub Site Specific Band 3		0		0.00
LDNO HVplus: LV Sub Site Specific Band 4		0		0.00
LDNO HVplus: HV Site Specific No Residual		0		0.00
LDNO HVplus: HV Site Specific Band 1		0		0.00
LDNO HVplus: HV Site Specific Band 2		0		0.00
LDNO HVplus: HV Site Specific Band 3		0		0.00
LDNO HVplus: HV Site Specific Band 4		0		0.00
LDNO EHV: Domestic Aggregated or CT with Residual		0, 1, 2	0.00	0.00
LDNO EHV: Non-Domestic Aggregated or CT No Residual		0, 3, 4, 5-8		0.00
LDNO EHV: Non-Domestic Aggregated or CT Band 1		0, 3, 4, 5-8		0.00
LDNO EHV: Non-Domestic Aggregated or CT Band 2		0, 3, 4, 5-8		0.00
LDNO EHV: Non-Domestic Aggregated or CT Band 3		0, 3, 4, 5-8		0.00
LDNO EHV: Non-Domestic Aggregated or CT Band 4		0, 3, 4, 5-8		0.00
LDNO EHV: LV Site Specific No Residual		0		0.00
LDNO EHV: LV Site Specific Band 1		0		0.00
LDNO EHV: LV Site Specific Band 2		0		0.00
LDNO EHV: LV Site Specific Band 3		0		0.00
LDNO EHV: LV Site Specific Band 4		0		0.00
LDNO EHV: LV Sub Site Specific No Residual		0		0.00
LDNO EHV: LV Sub Site Specific Band 1		0		0.00
LDNO EHV: LV Sub Site Specific Band 2		0		0.00
LDNO EHV: LV Sub Site Specific Band 3		0		0.00
LDNO EHV: LV Sub Site Specific Band 4		0		0.00
LDNO EHV: HV Site Specific No Residual		0		0.00
LDNO EHV: HV Site Specific Band 1		0		0.00
LDNO EHV: HV Site Specific Band 2		0		0.00
LDNO EHV: HV Site Specific Band 3		0		0.00
LDNO EHV: HV Site Specific Band 4		0		0.00
LDNO 132kV/EHV: Domestic Aggregated or CT with Residual		0, 1, 2	0.00	0.00
LDNO 132kV/EHV: Non-Domestic Aggregated or CT No Residual		0, 3, 4, 5-8		0.00

Tariff name	Open LLFCs / DUoS Tariff IDs / LDNO unique billing identifier	PCs	Supplier of Last Resort Fixed charge adder* p/MPAN/day	Eligible Bad Debt Fixed charge adder** p/MPAN/day
LDNO 132kV/EHV: Non-Domestic Aggregated or CT Band 1		0, 3, 4, 5-8		0.00
LDNO 132kV/EHV: Non-Domestic Aggregated or CT Band 2		0, 3, 4, 5-8		0.00
LDNO 132kV/EHV: Non-Domestic Aggregated or CT Band 3		0, 3, 4, 5-8		0.00
LDNO 132kV/EHV: Non-Domestic Aggregated or CT Band 4		0, 3, 4, 5-8		0.00
LDNO 132kV/EHV: LV Site Specific No Residual		0		0.00
LDNO 132kV/EHV: LV Site Specific Band 1		0		0.00
LDNO 132kV/EHV: LV Site Specific Band 2		0		0.00
LDNO 132kV/EHV: LV Site Specific Band 3		0		0.00
LDNO 132kV/EHV: LV Site Specific Band 4		0		0.00
LDNO 132kV/EHV: LV Sub Site Specific No Residual		0		0.00
LDNO 132kV/EHV: LV Sub Site Specific Band 1		0		0.00
LDNO 132kV/EHV: LV Sub Site Specific Band 2		0		0.00
LDNO 132kV/EHV: LV Sub Site Specific Band 3		0		0.00
LDNO 132kV/EHV: LV Sub Site Specific Band 4		0		0.00
LDNO 132kV/EHV: HV Site Specific No Residual		0		0.00
LDNO 132kV/EHV: HV Site Specific Band 1		0		0.00
LDNO 132kV/EHV: HV Site Specific Band 2		0		0.00
LDNO 132kV/EHV: HV Site Specific Band 3		0		0.00
LDNO 132kV/EHV: HV Site Specific Band 4		0		0.00
LDNO 132kV: Domestic Aggregated or CT with Residual		0, 1, 2	0.00	0.00
LDNO 132kV: Non-Domestic Aggregated or CT No Residual		0, 3, 4, 5-8		0.00
LDNO 132kV: Non-Domestic Aggregated or CT Band 1		0, 3, 4, 5-8		0.00
LDNO 132kV: Non-Domestic Aggregated or CT Band 2		0, 3, 4, 5-8		0.00
LDNO 132kV: Non-Domestic Aggregated or CT Band 3		0, 3, 4, 5-8		0.00
LDNO 132kV: Non-Domestic Aggregated or CT Band 4		0, 3, 4, 5-8		0.00
LDNO 132kV: LV Site Specific No Residual		0		0.00
LDNO 132kV: LV Site Specific Band 1		0		0.00
LDNO 132kV: LV Site Specific Band 2		0		0.00

Tariff name	Open LLFCs / DUoS Tariff IDs / LDNO unique billing identifier	PCs	Supplier of Last Resort Fixed charge adder* p/MPAN/day	Eligible Bad Debt Fixed charge adder** p/MPAN/day
LDNO 132kV: LV Site Specific Band 3		0		0.00
LDNO 132kV: LV Site Specific Band 4		0		0.00
LDNO 132kV: LV Sub Site Specific No Residual		0		0.00
LDNO 132kV: LV Sub Site Specific Band 1		0		0.00
LDNO 132kV: LV Sub Site Specific Band 2		0		0.00
LDNO 132kV: LV Sub Site Specific Band 3		0		0.00
LDNO 132kV: LV Sub Site Specific Band 4		0		0.00
LDNO 132kV: HV Site Specific No Residual		0		0.00
LDNO 132kV: HV Site Specific Band 1		0		0.00
LDNO 132kV: HV Site Specific Band 2		0		0.00
LDNO 132kV: HV Site Specific Band 3		0		0.00
LDNO 132kV: HV Site Specific Band 4		0		0.00
LDNO 0000: Domestic Aggregated or CT with Residual		0, 1, 2	0.00	0.00
LDNO 0000: Non-Domestic Aggregated or CT No Residual		0, 3, 4, 5-8		0.00
LDNO 0000: Non-Domestic Aggregated or CT Band 1		0, 3, 4, 5-8		0.00
LDNO 0000: Non-Domestic Aggregated or CT Band 2		0, 3, 4, 5-8		0.00
LDNO 0000: Non-Domestic Aggregated or CT Band 3		0, 3, 4, 5-8		0.00
LDNO 0000: Non-Domestic Aggregated or CT Band 4		0, 3, 4, 5-8		0.00
LDNO 0000: LV Site Specific No Residual		0		0.00
LDNO 0000: LV Site Specific Band 1		0		0.00
LDNO 0000: LV Site Specific Band 2		0		0.00
LDNO 0000: LV Site Specific Band 3		0		0.00
LDNO 0000: LV Site Specific Band 4		0		0.00
LDNO 0000: LV Sub Site Specific No Residual		0		0.00
LDNO 0000: LV Sub Site Specific Band 1		0		0.00
LDNO 0000: LV Sub Site Specific Band 2		0		0.00
LDNO 0000: LV Sub Site Specific Band 3		0		0.00
LDNO 0000: LV Sub Site Specific Band 4		0		0.00
LDNO 0000: HV Site Specific No Residual		0		0.00
LDNO 0000: HV Site Specific Band 1		0		0.00
LDNO 0000: HV Site Specific Band 2		0		0.00

Tariff name	Open LLFCs / DUoS Tariff IDs / LDNO unique billing identifier	PCs	Supplier of Last Resort Fixed charge adder* p/MPAN/day	Eligible Bad Debt Fixed charge adder** p/MPAN/day
LDNO 0000: HV Site Specific Band 3		0		0.00
LDNO 0000: HV Site Specific Band 4		0		0.00

## Annex 7 – Supplier of last Resort and Eligible Bad Debt Pass-Through Costs in “SP Electricity North West Area (GSP Group \_G)”

### Southern Electric Power Distribution plc - Effective from 1 April 2027 - Final Supplier of Last Resort and Eligible Bad Debt Pass-Through Costs in SP Electricity North West Area (GSP Group \_G)

Tariff name	Open LLFCs / DUoS Tariff IDs / LDNO unique billing identifier	PCs	Supplier of Last Resort Fixed charge adder* p/MPAN/day	Eligible Bad Debt Fixed charge adder** p/MPAN/day
Domestic Aggregated or CT with Residual	181, 261-262, 361-362, 480-481, 516, GA2	0, 1, 2	0.00	0.00
Non-Domestic Aggregated or CT No Residual	GA0, G10, G15, G20, G35, G40, G45, G55, G65, G70, G75, G90, GA3	0, 3, 4, 5-8		0.00
Non-Domestic Aggregated or CT Band 1	GA1, G11, G16, G21, G36, G41, G46, G56, G66, G71, G76, G91, GA4	0, 3, 4, 5-8		0.00
Non-Domestic Aggregated or CT Band 2	G02, G12, G17, G22, G37, G42, G47, G57, G67, G72, G77, G92, GA5	0, 3, 4, 5-8		0.00
Non-Domestic Aggregated or CT Band 3	G03, G13, G18, G23, G38, G43, G48, G58, G68, G73, G78, G93, GA6	0, 3, 4, 5-8		0.00
Non-Domestic Aggregated or CT Band 4	G04, G14, G19, G24, G39, G44, G49, G59, G69, G74, G79, G94, GA7	0, 3, 4, 5-8		0.00
LV Site Specific No Residual	G05, G30, G80	0		0.00
LV Site Specific Band 1	G06, G31, G81	0		0.00
LV Site Specific Band 2	G07, G32, G82	0		0.00
LV Site Specific Band 3	G08, G33, G83	0		0.00
LV Site Specific Band 4	G09, G34, G84	0		0.00
LV Sub Site Specific No Residual	G60, G95	0		0.00
LV Sub Site Specific Band 1	G61, G96	0		0.00
LV Sub Site Specific Band 2	G62, G97	0		0.00
LV Sub Site Specific Band 3	G63, G98	0		0.00
LV Sub Site Specific Band 4	G64, G99	0		0.00
HV Site Specific No Residual	G25, G50, G85	0		0.00
HV Site Specific Band 1	G26, G51, G86	0		0.00
HV Site Specific Band 2	G27, G52, G87	0		0.00
HV Site Specific Band 3	G28, G53, G88	0		0.00

Tariff name	Open LLCs / DUoS Tariff IDs / LDNO unique billing identifier	PCs	Supplier of Last Resort Fixed charge adder* p/MPAN/day	Eligible Bad Debt Fixed charge adder** p/MPAN/day
HV Site Specific Band 4	G29, G54, G89	0		0.00
LDNO LV: Domestic Aggregated or CT with Residual		0, 1, 2	0.00	0.00
LDNO LV: Non-Domestic Aggregated or CT No Residual		0, 3, 4, 5-8		0.00
LDNO LV: Non-Domestic Aggregated or CT Band 1		0, 3, 4, 5-8		0.00
LDNO LV: Non-Domestic Aggregated or CT Band 2		0, 3, 4, 5-8		0.00
LDNO LV: Non-Domestic Aggregated or CT Band 3		0, 3, 4, 5-8		0.00
LDNO LV: Non-Domestic Aggregated or CT Band 4		0, 3, 4, 5-8		0.00
LDNO LV: LV Site Specific No Residual		0		0.00
LDNO LV: LV Site Specific Band 1		0		0.00
LDNO LV: LV Site Specific Band 2		0		0.00
LDNO LV: LV Site Specific Band 3		0		0.00
LDNO LV: LV Site Specific Band 4		0		0.00
LDNO HV: Domestic Aggregated or CT with Residual		0, 1, 2	0.00	0.00
LDNO HV: Non-Domestic Aggregated or CT No Residual		0, 3, 4, 5-8		0.00
LDNO HV: Non-Domestic Aggregated or CT Band 1		0, 3, 4, 5-8		0.00
LDNO HV: Non-Domestic Aggregated or CT Band 2		0, 3, 4, 5-8		0.00
LDNO HV: Non-Domestic Aggregated or CT Band 3		0, 3, 4, 5-8		0.00
LDNO HV: Non-Domestic Aggregated or CT Band 4		0, 3, 4, 5-8		0.00
LDNO HV: LV Site Specific No Residual		0		0.00
LDNO HV: LV Site Specific Band 1		0		0.00
LDNO HV: LV Site Specific Band 2		0		0.00
LDNO HV: LV Site Specific Band 3		0		0.00
LDNO HV: LV Site Specific Band 4		0		0.00
LDNO HV: LV Sub Site Specific No Residual		0		0.00
LDNO HV: LV Sub Site Specific Band 1		0		0.00
LDNO HV: LV Sub Site Specific Band 2		0		0.00
LDNO HV: LV Sub Site Specific Band 3		0		0.00

Tariff name	Open LLFCs / DUoS Tariff IDs / LDNO unique billing identifier	PCs	Supplier of Last Resort Fixed charge adder* p/MPAN/day	Eligible Bad Debt Fixed charge adder** p/MPAN/day
LDNO HV: LV Sub Site Specific Band 4		0		0.00
LDNO HV: HV Site Specific No Residual		0		0.00
LDNO HV: HV Site Specific Band 1		0		0.00
LDNO HV: HV Site Specific Band 2		0		0.00
LDNO HV: HV Site Specific Band 3		0		0.00
LDNO HV: HV Site Specific Band 4		0		0.00
LDNO HVplus: Domestic Aggregated or CT with Residual		0, 1, 2	0.00	0.00
LDNO HVplus: Non-Domestic Aggregated or CT No Residual		0, 3, 4, 5-8		0.00
LDNO HVplus: Non-Domestic Aggregated or CT Band 1		0, 3, 4, 5-8		0.00
LDNO HVplus: Non-Domestic Aggregated or CT Band 2		0, 3, 4, 5-8		0.00
LDNO HVplus: Non-Domestic Aggregated or CT Band 3		0, 3, 4, 5-8		0.00
LDNO HVplus: Non-Domestic Aggregated or CT Band 4		0, 3, 4, 5-8		0.00
LDNO HVplus: LV Site Specific No Residual		0		0.00
LDNO HVplus: LV Site Specific Band 1		0		0.00
LDNO HVplus: LV Site Specific Band 2		0		0.00
LDNO HVplus: LV Site Specific Band 3		0		0.00
LDNO HVplus: LV Site Specific Band 4		0		0.00
LDNO HVplus: LV Sub Site Specific No Residual		0		0.00
LDNO HVplus: LV Sub Site Specific Band 1		0		0.00
LDNO HVplus: LV Sub Site Specific Band 2		0		0.00
LDNO HVplus: LV Sub Site Specific Band 3		0		0.00
LDNO HVplus: LV Sub Site Specific Band 4		0		0.00
LDNO HVplus: HV Site Specific No Residual		0		0.00
LDNO HVplus: HV Site Specific Band 1		0		0.00
LDNO HVplus: HV Site Specific Band 2		0		0.00
LDNO HVplus: HV Site Specific Band 3		0		0.00
LDNO HVplus: HV Site Specific Band 4		0		0.00
LDNO EHV: Domestic Aggregated or CT with Residual		0, 1, 2	0.00	0.00
LDNO EHV: Non-Domestic Aggregated or CT No Residual		0, 3, 4, 5-8		0.00

Tariff name	Open LLCs / DUoS Tariff IDs / LDNO unique billing identifier	PCs	Supplier of Last Resort Fixed charge adder* p/MPAN/day	Eligible Bad Debt Fixed charge adder** p/MPAN/day
LDNO EHV: Non-Domestic Aggregated or CT Band 1		0, 3, 4, 5-8		0.00
LDNO EHV: Non-Domestic Aggregated or CT Band 2		0, 3, 4, 5-8		0.00
LDNO EHV: Non-Domestic Aggregated or CT Band 3		0, 3, 4, 5-8		0.00
LDNO EHV: Non-Domestic Aggregated or CT Band 4		0, 3, 4, 5-8		0.00
LDNO EHV: LV Site Specific No Residual		0		0.00
LDNO EHV: LV Site Specific Band 1		0		0.00
LDNO EHV: LV Site Specific Band 2		0		0.00
LDNO EHV: LV Site Specific Band 3		0		0.00
LDNO EHV: LV Site Specific Band 4		0		0.00
LDNO EHV: LV Sub Site Specific No Residual		0		0.00
LDNO EHV: LV Sub Site Specific Band 1		0		0.00
LDNO EHV: LV Sub Site Specific Band 2		0		0.00
LDNO EHV: LV Sub Site Specific Band 3		0		0.00
LDNO EHV: LV Sub Site Specific Band 4		0		0.00
LDNO EHV: HV Site Specific No Residual		0		0.00
LDNO EHV: HV Site Specific Band 1		0		0.00
LDNO EHV: HV Site Specific Band 2		0		0.00
LDNO EHV: HV Site Specific Band 3		0		0.00
LDNO EHV: HV Site Specific Band 4		0		0.00
LDNO 132kV/EHV: Domestic Aggregated or CT with Residual		0, 1, 2	0.00	0.00
LDNO 132kV/EHV: Non-Domestic Aggregated or CT No Residual		0, 3, 4, 5-8		0.00
LDNO 132kV/EHV: Non-Domestic Aggregated or CT Band 1		0, 3, 4, 5-8		0.00
LDNO 132kV/EHV: Non-Domestic Aggregated or CT Band 2		0, 3, 4, 5-8		0.00
LDNO 132kV/EHV: Non-Domestic Aggregated or CT Band 3		0, 3, 4, 5-8		0.00
LDNO 132kV/EHV: Non-Domestic Aggregated or CT Band 4		0, 3, 4, 5-8		0.00
LDNO 132kV/EHV: LV Site Specific No Residual		0		0.00
LDNO 132kV/EHV: LV Site Specific Band 1		0		0.00
LDNO 132kV/EHV: LV Site Specific Band 2		0		0.00

Tariff name	Open LFCs / DUoS Tariff IDs / LDNO unique billing identifier	PCs	Supplier of Last Resort Fixed charge adder* p/MPAN/day	Eligible Bad Debt Fixed charge adder** p/MPAN/day
LDNO 132kV/EHV: LV Site Specific Band 3		0		0.00
LDNO 132kV/EHV: LV Site Specific Band 4		0		0.00
LDNO 132kV/EHV: LV Sub Site Specific No Residual		0		0.00
LDNO 132kV/EHV: LV Sub Site Specific Band 1		0		0.00
LDNO 132kV/EHV: LV Sub Site Specific Band 2		0		0.00
LDNO 132kV/EHV: LV Sub Site Specific Band 3		0		0.00
LDNO 132kV/EHV: LV Sub Site Specific Band 4		0		0.00
LDNO 132kV/EHV: HV Site Specific No Residual		0		0.00
LDNO 132kV/EHV: HV Site Specific Band 1		0		0.00
LDNO 132kV/EHV: HV Site Specific Band 2		0		0.00
LDNO 132kV/EHV: HV Site Specific Band 3		0		0.00
LDNO 132kV/EHV: HV Site Specific Band 4		0		0.00
LDNO 132kV: Domestic Aggregated or CT with Residual		0, 1, 2	0.00	0.00
LDNO 132kV: Non-Domestic Aggregated or CT No Residual		0, 3, 4, 5-8		0.00
LDNO 132kV: Non-Domestic Aggregated or CT Band 1		0, 3, 4, 5-8		0.00
LDNO 132kV: Non-Domestic Aggregated or CT Band 2		0, 3, 4, 5-8		0.00
LDNO 132kV: Non-Domestic Aggregated or CT Band 3		0, 3, 4, 5-8		0.00
LDNO 132kV: Non-Domestic Aggregated or CT Band 4		0, 3, 4, 5-8		0.00
LDNO 132kV: LV Site Specific No Residual		0		0.00
LDNO 132kV: LV Site Specific Band 1		0		0.00
LDNO 132kV: LV Site Specific Band 2		0		0.00
LDNO 132kV: LV Site Specific Band 3		0		0.00
LDNO 132kV: LV Site Specific Band 4		0		0.00
LDNO 132kV: LV Sub Site Specific No Residual		0		0.00
LDNO 132kV: LV Sub Site Specific Band 1		0		0.00
LDNO 132kV: LV Sub Site Specific Band 2		0		0.00
LDNO 132kV: LV Sub Site Specific Band 3		0		0.00
LDNO 132kV: LV Sub Site Specific Band 4		0		0.00
LDNO 132kV: HV Site Specific No Residual		0		0.00
LDNO 132kV: HV Site Specific Band 1		0		0.00
LDNO 132kV: HV Site Specific Band 2		0		0.00

Tariff name	Open LLFCs / DUoS Tariff IDs / LDNO unique billing identifier	PCs	Supplier of Last Resort Fixed charge adder* p/MPAN/day	Eligible Bad Debt Fixed charge adder** p/MPAN/day
LDNO 132kV: HV Site Specific Band 3		0		0.00
LDNO 132kV: HV Site Specific Band 4		0		0.00
LDNO 0000: Domestic Aggregated or CT with Residual		0, 1, 2	0.00	0.00
LDNO 0000: Non-Domestic Aggregated or CT No Residual		0, 3, 4, 5-8		0.00
LDNO 0000: Non-Domestic Aggregated or CT Band 1		0, 3, 4, 5-8		0.00
LDNO 0000: Non-Domestic Aggregated or CT Band 2		0, 3, 4, 5-8		0.00
LDNO 0000: Non-Domestic Aggregated or CT Band 3		0, 3, 4, 5-8		0.00
LDNO 0000: Non-Domestic Aggregated or CT Band 4		0, 3, 4, 5-8		0.00
LDNO 0000: LV Site Specific No Residual		0		0.00
LDNO 0000: LV Site Specific Band 1		0		0.00
LDNO 0000: LV Site Specific Band 2		0		0.00
LDNO 0000: LV Site Specific Band 3		0		0.00
LDNO 0000: LV Site Specific Band 4		0		0.00
LDNO 0000: LV Sub Site Specific No Residual		0		0.00
LDNO 0000: LV Sub Site Specific Band 1		0		0.00
LDNO 0000: LV Sub Site Specific Band 2		0		0.00
LDNO 0000: LV Sub Site Specific Band 3		0		0.00
LDNO 0000: LV Sub Site Specific Band 4		0		0.00
LDNO 0000: HV Site Specific No Residual		0		0.00
LDNO 0000: HV Site Specific Band 1		0		0.00
LDNO 0000: HV Site Specific Band 2		0		0.00
LDNO 0000: HV Site Specific Band 3		0		0.00
LDNO 0000: HV Site Specific Band 4		0		0.00

## Annex 7 – Supplier of last Resort and Eligible Bad Debt Pass-Through Costs in “South Eastern Power Networks Area (GSP Group \_J)”

### Southern Electric Power Distribution plc - Effective from 1 April 2027 - Final Supplier of Last Resort and Eligible Bad Debt Pass-Through Costs in UKPN SPN Area (GSP Group \_J)

Tariff name	Open LLFCs / DUoS Tariff IDs / LDNO unique billing identifier	PCs	Supplier of Last Resort Fixed charge adder* p/MPAN/day	Eligible Bad Debt Fixed charge adder** p/MPAN/day
Domestic Aggregated or CT with Residual	183, 371-372, 471-472, JA0	0, 1, 2	0.00	0.00
Non-Domestic Aggregated or CT No Residual	J10, J15, J20, J30, J40, J45, J50, JA1	0, 3, 4, 5-8		0.00
Non-Domestic Aggregated or CT Band 1	J11, J16, J21, J31, J41, J46, J51, JA2	0, 3, 4, 5-8		0.00
Non-Domestic Aggregated or CT Band 2	J12, J17, J22, J32, J42, J47, J52, JA3	0, 3, 4, 5-8		0.00
Non-Domestic Aggregated or CT Band 3	J13, J18, J23, J33, J43, J48, J53, JA4	0, 3, 4, 5-8		0.00
Non-Domestic Aggregated or CT Band 4	J14, J19, J24, J34, J44, J49, J54, JA5	0, 3, 4, 5-8		0.00
LV Site Specific No Residual	J05	0		0.00
LV Site Specific Band 1	J06	0		0.00
LV Site Specific Band 2	J07	0		0.00
LV Site Specific Band 3	J08	0		0.00
LV Site Specific Band 4	J09	0		0.00
LV Sub Site Specific No Residual	J35	0		0.00
LV Sub Site Specific Band 1	J36	0		0.00
LV Sub Site Specific Band 2	J37	0		0.00
LV Sub Site Specific Band 3	J38	0		0.00
LV Sub Site Specific Band 4	J39	0		0.00
HV Site Specific No Residual	J25	0		0.00
HV Site Specific Band 1	J26	0		0.00
HV Site Specific Band 2	J27	0		0.00
HV Site Specific Band 3	J28	0		0.00
HV Site Specific Band 4	J29	0		0.00
LDNO LV: Domestic Aggregated or CT with Residual		0, 1, 2	0.00	0.00
LDNO LV: Non-Domestic Aggregated or CT No Residual		0, 3, 4, 5-8		0.00

Tariff name	Open LLFCs / DUoS Tariff IDs / LDNO unique billing identifier	PCs	Supplier of Last Resort Fixed charge adder* p/MPAN/day	Eligible Bad Debt Fixed charge adder** p/MPAN/day
LDNO LV: Non-Domestic Aggregated or CT Band 1		0, 3, 4, 5-8		0.00
LDNO LV: Non-Domestic Aggregated or CT Band 2		0, 3, 4, 5-8		0.00
LDNO LV: Non-Domestic Aggregated or CT Band 3		0, 3, 4, 5-8		0.00
LDNO LV: Non-Domestic Aggregated or CT Band 4		0, 3, 4, 5-8		0.00
LDNO LV: LV Site Specific No Residual		0		0.00
LDNO LV: LV Site Specific Band 1		0		0.00
LDNO LV: LV Site Specific Band 2		0		0.00
LDNO LV: LV Site Specific Band 3		0		0.00
LDNO LV: LV Site Specific Band 4		0		0.00
LDNO HV: Domestic Aggregated or CT with Residual		0, 1, 2	0.00	0.00
LDNO HV: Non-Domestic Aggregated or CT No Residual		0, 3, 4, 5-8		0.00
LDNO HV: Non-Domestic Aggregated or CT Band 1		0, 3, 4, 5-8		0.00
LDNO HV: Non-Domestic Aggregated or CT Band 2		0, 3, 4, 5-8		0.00
LDNO HV: Non-Domestic Aggregated or CT Band 3		0, 3, 4, 5-8		0.00
LDNO HV: Non-Domestic Aggregated or CT Band 4		0, 3, 4, 5-8		0.00
LDNO HV: LV Site Specific No Residual		0		0.00
LDNO HV: LV Site Specific Band 1		0		0.00
LDNO HV: LV Site Specific Band 2		0		0.00
LDNO HV: LV Site Specific Band 3		0		0.00
LDNO HV: LV Site Specific Band 4		0		0.00
LDNO HV: LV Sub Site Specific No Residual		0		0.00
LDNO HV: LV Sub Site Specific Band 1		0		0.00
LDNO HV: LV Sub Site Specific Band 2		0		0.00
LDNO HV: LV Sub Site Specific Band 3		0		0.00
LDNO HV: LV Sub Site Specific Band 4		0		0.00
LDNO HV: HV Site Specific No Residual		0		0.00
LDNO HV: HV Site Specific Band 1		0		0.00
LDNO HV: HV Site Specific Band 2		0		0.00

Tariff name	Open LLFCs / DUoS Tariff IDs / LDNO unique billing identifier	PCs	Supplier of Last Resort Fixed charge adder* p/MPAN/day	Eligible Bad Debt Fixed charge adder** p/MPAN/day
LDNO HV: HV Site Specific Band 3		0		0.00
LDNO HV: HV Site Specific Band 4		0		0.00
LDNO HVplus: Domestic Aggregated or CT with Residual		0, 1, 2	0.00	0.00
LDNO HVplus: Non-Domestic Aggregated or CT No Residual		0, 3, 4, 5-8		0.00
LDNO HVplus: Non-Domestic Aggregated or CT Band 1		0, 3, 4, 5-8		0.00
LDNO HVplus: Non-Domestic Aggregated or CT Band 2		0, 3, 4, 5-8		0.00
LDNO HVplus: Non-Domestic Aggregated or CT Band 3		0, 3, 4, 5-8		0.00
LDNO HVplus: Non-Domestic Aggregated or CT Band 4		0, 3, 4, 5-8		0.00
LDNO HVplus: LV Site Specific No Residual		0		0.00
LDNO HVplus: LV Site Specific Band 1		0		0.00
LDNO HVplus: LV Site Specific Band 2		0		0.00
LDNO HVplus: LV Site Specific Band 3		0		0.00
LDNO HVplus: LV Site Specific Band 4		0		0.00
LDNO HVplus: LV Sub Site Specific No Residual		0		0.00
LDNO HVplus: LV Sub Site Specific Band 1		0		0.00
LDNO HVplus: LV Sub Site Specific Band 2		0		0.00
LDNO HVplus: LV Sub Site Specific Band 3		0		0.00
LDNO HVplus: LV Sub Site Specific Band 4		0		0.00
LDNO HVplus: HV Site Specific No Residual		0		0.00
LDNO HVplus: HV Site Specific Band 1		0		0.00
LDNO HVplus: HV Site Specific Band 2		0		0.00
LDNO HVplus: HV Site Specific Band 3		0		0.00
LDNO HVplus: HV Site Specific Band 4		0		0.00
LDNO EHV: Domestic Aggregated or CT with Residual		0, 1, 2	0.00	0.00
LDNO EHV: Non-Domestic Aggregated or CT No Residual		0, 3, 4, 5-8		0.00
LDNO EHV: Non-Domestic Aggregated or CT Band 1		0, 3, 4, 5-8		0.00
LDNO EHV: Non-Domestic Aggregated or CT Band 2		0, 3, 4, 5-8		0.00
LDNO EHV: Non-Domestic Aggregated or CT Band 3		0, 3, 4, 5-8		0.00

Tariff name	Open LLFCs / DUoS Tariff IDs / LDNO unique billing identifier	PCs	Supplier of Last Resort Fixed charge adder* p/MPAN/day	Eligible Bad Debt Fixed charge adder** p/MPAN/day
LDNO EHV: Non-Domestic Aggregated or CT Band 4		0, 3, 4, 5-8		0.00
LDNO EHV: LV Site Specific No Residual		0		0.00
LDNO EHV: LV Site Specific Band 1		0		0.00
LDNO EHV: LV Site Specific Band 2		0		0.00
LDNO EHV: LV Site Specific Band 3		0		0.00
LDNO EHV: LV Site Specific Band 4		0		0.00
LDNO EHV: LV Sub Site Specific No Residual		0		0.00
LDNO EHV: LV Sub Site Specific Band 1		0		0.00
LDNO EHV: LV Sub Site Specific Band 2		0		0.00
LDNO EHV: LV Sub Site Specific Band 3		0		0.00
LDNO EHV: LV Sub Site Specific Band 4		0		0.00
LDNO EHV: HV Site Specific No Residual		0		0.00
LDNO EHV: HV Site Specific Band 1		0		0.00
LDNO EHV: HV Site Specific Band 2		0		0.00
LDNO EHV: HV Site Specific Band 3		0		0.00
LDNO EHV: HV Site Specific Band 4		0		0.00
LDNO 132kV/EHV: Domestic Aggregated or CT with Residual		0, 1, 2	0.00	0.00
LDNO 132kV/EHV: Non-Domestic Aggregated or CT No Residual		0, 3, 4, 5-8		0.00
LDNO 132kV/EHV: Non-Domestic Aggregated or CT Band 1		0, 3, 4, 5-8		0.00
LDNO 132kV/EHV: Non-Domestic Aggregated or CT Band 2		0, 3, 4, 5-8		0.00
LDNO 132kV/EHV: Non-Domestic Aggregated or CT Band 3		0, 3, 4, 5-8		0.00
LDNO 132kV/EHV: Non-Domestic Aggregated or CT Band 4		0, 3, 4, 5-8		0.00
LDNO 132kV/EHV: LV Site Specific No Residual		0		0.00
LDNO 132kV/EHV: LV Site Specific Band 1		0		0.00
LDNO 132kV/EHV: LV Site Specific Band 2		0		0.00
LDNO 132kV/EHV: LV Site Specific Band 3		0		0.00
LDNO 132kV/EHV: LV Site Specific Band 4		0		0.00
LDNO 132kV/EHV: LV Sub Site Specific No Residual		0		0.00
LDNO 132kV/EHV: LV Sub Site Specific Band 1		0		0.00
LDNO 132kV/EHV: LV Sub Site Specific Band 2		0		0.00

Tariff name	Open LLCs / DUoS Tariff IDs / LDNO unique billing identifier	PCs	Supplier of Last Resort Fixed charge adder* p/MPAN/day	Eligible Bad Debt Fixed charge adder** p/MPAN/day
LDNO 132kV/EHV: LV Sub Site Specific Band 3		0		0.00
LDNO 132kV/EHV: LV Sub Site Specific Band 4		0		0.00
LDNO 132kV/EHV: HV Site Specific No Residual		0		0.00
LDNO 132kV/EHV: HV Site Specific Band 1		0		0.00
LDNO 132kV/EHV: HV Site Specific Band 2		0		0.00
LDNO 132kV/EHV: HV Site Specific Band 3		0		0.00
LDNO 132kV/EHV: HV Site Specific Band 4		0		0.00
LDNO 132kV: Domestic Aggregated or CT with Residual		0, 1, 2	0.00	0.00
LDNO 132kV: Non-Domestic Aggregated or CT No Residual		0, 3, 4, 5-8		0.00
LDNO 132kV: Non-Domestic Aggregated or CT Band 1		0, 3, 4, 5-8		0.00
LDNO 132kV: Non-Domestic Aggregated or CT Band 2		0, 3, 4, 5-8		0.00
LDNO 132kV: Non-Domestic Aggregated or CT Band 3		0, 3, 4, 5-8		0.00
LDNO 132kV: Non-Domestic Aggregated or CT Band 4		0, 3, 4, 5-8		0.00
LDNO 132kV: LV Site Specific No Residual		0		0.00
LDNO 132kV: LV Site Specific Band 1		0		0.00
LDNO 132kV: LV Site Specific Band 2		0		0.00
LDNO 132kV: LV Site Specific Band 3		0		0.00
LDNO 132kV: LV Site Specific Band 4		0		0.00
LDNO 132kV: LV Sub Site Specific No Residual		0		0.00
LDNO 132kV: LV Sub Site Specific Band 1		0		0.00
LDNO 132kV: LV Sub Site Specific Band 2		0		0.00
LDNO 132kV: LV Sub Site Specific Band 3		0		0.00
LDNO 132kV: LV Sub Site Specific Band 4		0		0.00
LDNO 132kV: HV Site Specific No Residual		0		0.00
LDNO 132kV: HV Site Specific Band 1		0		0.00
LDNO 132kV: HV Site Specific Band 2		0		0.00
LDNO 132kV: HV Site Specific Band 3		0		0.00
LDNO 132kV: HV Site Specific Band 4		0		0.00
LDNO 0000: Domestic Aggregated or CT with Residual		0, 1, 2	0.00	0.00
LDNO 0000: Non-Domestic Aggregated or CT No Residual		0, 3, 4, 5-8		0.00

Tariff name	Open LLFCs / DUoS Tariff IDs / LDNO unique billing identifier	PCs	Supplier of Last Resort Fixed charge adder* p/MPAN/day	Eligible Bad Debt Fixed charge adder** p/MPAN/day
LDNO 0000: Non-Domestic Aggregated or CT Band 1		0, 3, 4, 5-8		0.00
LDNO 0000: Non-Domestic Aggregated or CT Band 2		0, 3, 4, 5-8		0.00
LDNO 0000: Non-Domestic Aggregated or CT Band 3		0, 3, 4, 5-8		0.00
LDNO 0000: Non-Domestic Aggregated or CT Band 4		0, 3, 4, 5-8		0.00
LDNO 0000: LV Site Specific No Residual		0		0.00
LDNO 0000: LV Site Specific Band 1		0		0.00
LDNO 0000: LV Site Specific Band 2		0		0.00
LDNO 0000: LV Site Specific Band 3		0		0.00
LDNO 0000: LV Site Specific Band 4		0		0.00
LDNO 0000: LV Sub Site Specific No Residual		0		0.00
LDNO 0000: LV Sub Site Specific Band 1		0		0.00
LDNO 0000: LV Sub Site Specific Band 2		0		0.00
LDNO 0000: LV Sub Site Specific Band 3		0		0.00
LDNO 0000: LV Sub Site Specific Band 4		0		0.00
LDNO 0000: HV Site Specific No Residual		0		0.00
LDNO 0000: HV Site Specific Band 1		0		0.00
LDNO 0000: HV Site Specific Band 2		0		0.00
LDNO 0000: HV Site Specific Band 3		0		0.00
LDNO 0000: HV Site Specific Band 4		0		0.00

## Annex 7 – Supplier of last Resort and Eligible Bad Debt Pass-Through Costs in “NGED South Wales Area (GSP Group \_K)”

### Southern Electric Power Distribution plc - Effective from 1 April 2027 - Final Supplier of Last Resort and Eligible Bad Debt Pass-Through Costs in NGED South Wales Area (GSP Group \_K)

Tariff name	Open LLFCs / DUoS Tariff IDs / LDNO unique billing identifier	PCs	Supplier of Last Resort Fixed charge adder* p/MPAN/day	Eligible Bad Debt Fixed charge adder** p/MPAN/day
Domestic Aggregated or CT with Residual	81-82, 91-92, 98-99, 185, 291-292, 518, K04, KA0	0, 1, 2	0.00	0.00
Non-Domestic Aggregated or CT No Residual	K10, K30, K35, K40, K50, K60, K65, K70, K80, K90, K95, R45, R50, KA1	0, 3, 4, 5-8		0.00
Non-Domestic Aggregated or CT Band 1	K11, K31, K36, K41, K51, K61, K66, K71, K81, K91, K96, R46, R51, KA2	0, 3, 4, 5-8		0.00
Non-Domestic Aggregated or CT Band 2	K12, K32, K37, K42, K52, K62, K67, K72, K82, K92, K97, R47, R52, KA3	0, 3, 4, 5-8		0.00
Non-Domestic Aggregated or CT Band 3	K13, K33, K38, K43, K53, K63, K68, K73, K83, K93, K98, R48, R53, KA4	0, 3, 4, 5-8		0.00
Non-Domestic Aggregated or CT Band 4	K14, K34, K39, K44, K54, K64, K69, K74, K84, K94, K99, R49, R54, KA5	0, 3, 4, 5-8		0.00
LV Site Specific No Residual	K15, K25, K55	0		0.00
LV Site Specific Band 1	K16, K26, K56	0		0.00
LV Site Specific Band 2	K17, K27, K57	0		0.00
LV Site Specific Band 3	K18, K28, K58	0		0.00
LV Site Specific Band 4	K19, K29, K59	0		0.00
LV Sub Site Specific No Residual	K85	0		0.00
LV Sub Site Specific Band 1	K86	0		0.00
LV Sub Site Specific Band 2	K87	0		0.00
LV Sub Site Specific Band 3	K88	0		0.00
LV Sub Site Specific Band 4	K89	0		0.00
HV Site Specific No Residual	K20, K45, K75	0		0.00
HV Site Specific Band 1	K21, K46, K76	0		0.00
HV Site Specific Band 2	K22, K47, K77	0		0.00

Tariff name	Open LLFCs / DUoS Tariff IDs / LDNO unique billing identifier	PCs	Supplier of Last Resort Fixed charge adder* p/MPAN/day	Eligible Bad Debt Fixed charge adder** p/MPAN/day
HV Site Specific Band 3	K23, K48, K78	0		0.00
HV Site Specific Band 4	K24, K49, K79	0		0.00
LDNO LV: Domestic Aggregated or CT with Residual		0, 1, 2	0.00	0.00
LDNO LV: Non-Domestic Aggregated or CT No Residual		0, 3, 4, 5-8		0.00
LDNO LV: Non-Domestic Aggregated or CT Band 1		0, 3, 4, 5-8		0.00
LDNO LV: Non-Domestic Aggregated or CT Band 2		0, 3, 4, 5-8		0.00
LDNO LV: Non-Domestic Aggregated or CT Band 3		0, 3, 4, 5-8		0.00
LDNO LV: Non-Domestic Aggregated or CT Band 4		0, 3, 4, 5-8		0.00
LDNO LV: LV Site Specific No Residual		0		0.00
LDNO LV: LV Site Specific Band 1		0		0.00
LDNO LV: LV Site Specific Band 2		0		0.00
LDNO LV: LV Site Specific Band 3		0		0.00
LDNO LV: LV Site Specific Band 4		0		0.00
LDNO HV: Domestic Aggregated or CT with Residual		0, 1, 2	0.00	0.00
LDNO HV: Non-Domestic Aggregated or CT No Residual		0, 3, 4, 5-8		0.00
LDNO HV: Non-Domestic Aggregated or CT Band 1		0, 3, 4, 5-8		0.00
LDNO HV: Non-Domestic Aggregated or CT Band 2		0, 3, 4, 5-8		0.00
LDNO HV: Non-Domestic Aggregated or CT Band 3		0, 3, 4, 5-8		0.00
LDNO HV: Non-Domestic Aggregated or CT Band 4		0, 3, 4, 5-8		0.00
LDNO HV: LV Site Specific No Residual		0		0.00
LDNO HV: LV Site Specific Band 1		0		0.00
LDNO HV: LV Site Specific Band 2		0		0.00
LDNO HV: LV Site Specific Band 3		0		0.00
LDNO HV: LV Site Specific Band 4		0		0.00
LDNO HV: LV Sub Site Specific No Residual		0		0.00
LDNO HV: LV Sub Site Specific Band 1		0		0.00
LDNO HV: LV Sub Site Specific Band 2		0		0.00

Tariff name	Open LLCs / DUoS Tariff IDs / LDNO unique billing identifier	PCs	Supplier of Last Resort Fixed charge adder* p/MPAN/day	Eligible Bad Debt Fixed charge adder** p/MPAN/day
LDNO HV: LV Sub Site Specific Band 3		0		0.00
LDNO HV: LV Sub Site Specific Band 4		0		0.00
LDNO HV: HV Site Specific No Residual		0		0.00
LDNO HV: HV Site Specific Band 1		0		0.00
LDNO HV: HV Site Specific Band 2		0		0.00
LDNO HV: HV Site Specific Band 3		0		0.00
LDNO HV: HV Site Specific Band 4		0		0.00
LDNO HVplus: Domestic Aggregated or CT with Residual		0, 1, 2	0.00	0.00
LDNO HVplus: Non-Domestic Aggregated or CT No Residual		0, 3, 4, 5-8		0.00
LDNO HVplus: Non-Domestic Aggregated or CT Band 1		0, 3, 4, 5-8		0.00
LDNO HVplus: Non-Domestic Aggregated or CT Band 2		0, 3, 4, 5-8		0.00
LDNO HVplus: Non-Domestic Aggregated or CT Band 3		0, 3, 4, 5-8		0.00
LDNO HVplus: Non-Domestic Aggregated or CT Band 4		0, 3, 4, 5-8		0.00
LDNO HVplus: LV Site Specific No Residual		0		0.00
LDNO HVplus: LV Site Specific Band 1		0		0.00
LDNO HVplus: LV Site Specific Band 2		0		0.00
LDNO HVplus: LV Site Specific Band 3		0		0.00
LDNO HVplus: LV Site Specific Band 4		0		0.00
LDNO HVplus: LV Sub Site Specific No Residual		0		0.00
LDNO HVplus: LV Sub Site Specific Band 1		0		0.00
LDNO HVplus: LV Sub Site Specific Band 2		0		0.00
LDNO HVplus: LV Sub Site Specific Band 3		0		0.00
LDNO HVplus: LV Sub Site Specific Band 4		0		0.00
LDNO HVplus: HV Site Specific No Residual		0		0.00
LDNO HVplus: HV Site Specific Band 1		0		0.00
LDNO HVplus: HV Site Specific Band 2		0		0.00
LDNO HVplus: HV Site Specific Band 3		0		0.00
LDNO HVplus: HV Site Specific Band 4		0		0.00
LDNO EHV: Domestic Aggregated or CT with Residual		0, 1, 2	0.00	0.00
LDNO EHV: Non-Domestic Aggregated or CT No Residual		0, 3, 4, 5-8		0.00

Tariff name	Open LLCs / DUoS Tariff IDs / LDNO unique billing identifier	PCs	Supplier of Last Resort Fixed charge adder* p/MPAN/day	Eligible Bad Debt Fixed charge adder** p/MPAN/day
LDNO EHV: Non-Domestic Aggregated or CT Band 1		0, 3, 4, 5-8		0.00
LDNO EHV: Non-Domestic Aggregated or CT Band 2		0, 3, 4, 5-8		0.00
LDNO EHV: Non-Domestic Aggregated or CT Band 3		0, 3, 4, 5-8		0.00
LDNO EHV: Non-Domestic Aggregated or CT Band 4		0, 3, 4, 5-8		0.00
LDNO EHV: LV Site Specific No Residual		0		0.00
LDNO EHV: LV Site Specific Band 1		0		0.00
LDNO EHV: LV Site Specific Band 2		0		0.00
LDNO EHV: LV Site Specific Band 3		0		0.00
LDNO EHV: LV Site Specific Band 4		0		0.00
LDNO EHV: LV Sub Site Specific No Residual		0		0.00
LDNO EHV: LV Sub Site Specific Band 1		0		0.00
LDNO EHV: LV Sub Site Specific Band 2		0		0.00
LDNO EHV: LV Sub Site Specific Band 3		0		0.00
LDNO EHV: LV Sub Site Specific Band 4		0		0.00
LDNO EHV: HV Site Specific No Residual		0		0.00
LDNO EHV: HV Site Specific Band 1		0		0.00
LDNO EHV: HV Site Specific Band 2		0		0.00
LDNO EHV: HV Site Specific Band 3		0		0.00
LDNO EHV: HV Site Specific Band 4		0		0.00
LDNO 132kV/EHV: Domestic Aggregated or CT with Residual		0, 1, 2	0.00	0.00
LDNO 132kV/EHV: Non-Domestic Aggregated or CT No Residual		0, 3, 4, 5-8		0.00
LDNO 132kV/EHV: Non-Domestic Aggregated or CT Band 1		0, 3, 4, 5-8		0.00
LDNO 132kV/EHV: Non-Domestic Aggregated or CT Band 2		0, 3, 4, 5-8		0.00
LDNO 132kV/EHV: Non-Domestic Aggregated or CT Band 3		0, 3, 4, 5-8		0.00
LDNO 132kV/EHV: Non-Domestic Aggregated or CT Band 4		0, 3, 4, 5-8		0.00
LDNO 132kV/EHV: LV Site Specific No Residual		0		0.00
LDNO 132kV/EHV: LV Site Specific Band 1		0		0.00
LDNO 132kV/EHV: LV Site Specific Band 2		0		0.00

Tariff name	Open LLFCs / DUoS Tariff IDs / LDNO unique billing identifier	PCs	Supplier of Last Resort Fixed charge adder* p/MPAN/day	Eligible Bad Debt Fixed charge adder** p/MPAN/day
LDNO 132kV/EHV: LV Site Specific Band 3		0		0.00
LDNO 132kV/EHV: LV Site Specific Band 4		0		0.00
LDNO 132kV/EHV: LV Sub Site Specific No Residual		0		0.00
LDNO 132kV/EHV: LV Sub Site Specific Band 1		0		0.00
LDNO 132kV/EHV: LV Sub Site Specific Band 2		0		0.00
LDNO 132kV/EHV: LV Sub Site Specific Band 3		0		0.00
LDNO 132kV/EHV: LV Sub Site Specific Band 4		0		0.00
LDNO 132kV/EHV: HV Site Specific No Residual		0		0.00
LDNO 132kV/EHV: HV Site Specific Band 1		0		0.00
LDNO 132kV/EHV: HV Site Specific Band 2		0		0.00
LDNO 132kV/EHV: HV Site Specific Band 3		0		0.00
LDNO 132kV/EHV: HV Site Specific Band 4		0		0.00
LDNO 132kV: Domestic Aggregated or CT with Residual		0, 1, 2	0.00	0.00
LDNO 132kV: Non-Domestic Aggregated or CT No Residual		0, 3, 4, 5-8		0.00
LDNO 132kV: Non-Domestic Aggregated or CT Band 1		0, 3, 4, 5-8		0.00
LDNO 132kV: Non-Domestic Aggregated or CT Band 2		0, 3, 4, 5-8		0.00
LDNO 132kV: Non-Domestic Aggregated or CT Band 3		0, 3, 4, 5-8		0.00
LDNO 132kV: Non-Domestic Aggregated or CT Band 4		0, 3, 4, 5-8		0.00
LDNO 132kV: LV Site Specific No Residual		0		0.00
LDNO 132kV: LV Site Specific Band 1		0		0.00
LDNO 132kV: LV Site Specific Band 2		0		0.00
LDNO 132kV: LV Site Specific Band 3		0		0.00
LDNO 132kV: LV Site Specific Band 4		0		0.00
LDNO 132kV: LV Sub Site Specific No Residual		0		0.00
LDNO 132kV: LV Sub Site Specific Band 1		0		0.00
LDNO 132kV: LV Sub Site Specific Band 2		0		0.00
LDNO 132kV: LV Sub Site Specific Band 3		0		0.00
LDNO 132kV: LV Sub Site Specific Band 4		0		0.00
LDNO 132kV: HV Site Specific No Residual		0		0.00
LDNO 132kV: HV Site Specific Band 1		0		0.00
LDNO 132kV: HV Site Specific Band 2		0		0.00

Tariff name	Open LLFCs / DUoS Tariff IDs / LDNO unique billing identifier	PCs	Supplier of Last Resort Fixed charge adder* p/MPAN/day	Eligible Bad Debt Fixed charge adder** p/MPAN/day
LDNO 132kV: HV Site Specific Band 3		0		0.00
LDNO 132kV: HV Site Specific Band 4		0		0.00
LDNO 0000: Domestic Aggregated or CT with Residual		0, 1, 2	0.00	0.00
LDNO 0000: Non-Domestic Aggregated or CT No Residual		0, 3, 4, 5-8		0.00
LDNO 0000: Non-Domestic Aggregated or CT Band 1		0, 3, 4, 5-8		0.00
LDNO 0000: Non-Domestic Aggregated or CT Band 2		0, 3, 4, 5-8		0.00
LDNO 0000: Non-Domestic Aggregated or CT Band 3		0, 3, 4, 5-8		0.00
LDNO 0000: Non-Domestic Aggregated or CT Band 4		0, 3, 4, 5-8		0.00
LDNO 0000: LV Site Specific No Residual		0		0.00
LDNO 0000: LV Site Specific Band 1		0		0.00
LDNO 0000: LV Site Specific Band 2		0		0.00
LDNO 0000: LV Site Specific Band 3		0		0.00
LDNO 0000: LV Site Specific Band 4		0		0.00
LDNO 0000: LV Sub Site Specific No Residual		0		0.00
LDNO 0000: LV Sub Site Specific Band 1		0		0.00
LDNO 0000: LV Sub Site Specific Band 2		0		0.00
LDNO 0000: LV Sub Site Specific Band 3		0		0.00
LDNO 0000: LV Sub Site Specific Band 4		0		0.00
LDNO 0000: HV Site Specific No Residual		0		0.00
LDNO 0000: HV Site Specific Band 1		0		0.00
LDNO 0000: HV Site Specific Band 2		0		0.00
LDNO 0000: HV Site Specific Band 3		0		0.00
LDNO 0000: HV Site Specific Band 4		0		0.00

## Annex 7 – Supplier of last Resort and Eligible Bad Debt Pass-Through Costs in “NGED South West Area (GSP Group \_L)”

### Southern Electric Power Distribution plc - Effective from 1 April 2027 - Final Supplier of Last Resort and Eligible Bad Debt Pass-Through Costs in NGED South West Area (GSP Group \_L)

Tariff name	Open LLFCs / DUoS Tariff IDs / LDNO unique billing identifier	PCs	Supplier of Last Resort Fixed charge adder* p/MPAN/day	Eligible Bad Debt Fixed charge adder** p/MPAN/day
Domestic Aggregated or CT with Residual	187, 381-382, L08, LA0	0, 1, 2	0.00	0.00
Non-Domestic Aggregated or CT No Residual	L10, L15, L20, L30, L45, L50, L55, R55, LA1	0, 3, 4, 5-8		0.00
Non-Domestic Aggregated or CT Band 1	L11, L16, L21, L31, L46, L51, L56, R56, LA2	0, 3, 4, 5-8		0.00
Non-Domestic Aggregated or CT Band 2	L12, L17, L22, L32, L47, L52, L57, R57, LA3	0, 3, 4, 5-8		0.00
Non-Domestic Aggregated or CT Band 3	L13, L18, L23, L33, L48, L53, L58, R58, LA4	0, 3, 4, 5-8		0.00
Non-Domestic Aggregated or CT Band 4	L14, L19, L24, L34, L49, L54, L59, R59, LA5	0, 3, 4, 5-8		0.00
LV Site Specific No Residual	L60, R60	0		0.00
LV Site Specific Band 1	L61, R61	0		0.00
LV Site Specific Band 2	L62, R62	0		0.00
LV Site Specific Band 3	L63, R63	0		0.00
LV Site Specific Band 4	L64, R64	0		0.00
LV Sub Site Specific No Residual	L35	0		0.00
LV Sub Site Specific Band 1	L36	0		0.00
LV Sub Site Specific Band 2	L37	0		0.00
LV Sub Site Specific Band 3	L38	0		0.00
LV Sub Site Specific Band 4	L39	0		0.00
HV Site Specific No Residual	L25, L40	0		0.00
HV Site Specific Band 1	L26, L41	0		0.00
HV Site Specific Band 2	L27, L42	0		0.00
HV Site Specific Band 3	L28, L43	0		0.00
HV Site Specific Band 4	L29, L44	0		0.00
LDNO LV: Domestic Aggregated or CT with Residual		0, 1, 2	0.00	0.00
LDNO LV: Non-Domestic Aggregated or CT No Residual		0, 3, 4, 5-8		0.00

Tariff name	Open LLCs / DUoS Tariff IDs / LDNO unique billing identifier	PCs	Supplier of Last Resort Fixed charge adder* p/MPAN/day	Eligible Bad Debt Fixed charge adder** p/MPAN/day
LDNO LV: Non-Domestic Aggregated or CT Band 1		0, 3, 4, 5-8		0.00
LDNO LV: Non-Domestic Aggregated or CT Band 2		0, 3, 4, 5-8		0.00
LDNO LV: Non-Domestic Aggregated or CT Band 3		0, 3, 4, 5-8		0.00
LDNO LV: Non-Domestic Aggregated or CT Band 4		0, 3, 4, 5-8		0.00
LDNO LV: LV Site Specific No Residual		0		0.00
LDNO LV: LV Site Specific Band 1		0		0.00
LDNO LV: LV Site Specific Band 2		0		0.00
LDNO LV: LV Site Specific Band 3		0		0.00
LDNO LV: LV Site Specific Band 4		0		0.00
LDNO HV: Domestic Aggregated or CT with Residual		0, 1, 2	0.00	0.00
LDNO HV: Non-Domestic Aggregated or CT No Residual		0, 3, 4, 5-8		0.00
LDNO HV: Non-Domestic Aggregated or CT Band 1		0, 3, 4, 5-8		0.00
LDNO HV: Non-Domestic Aggregated or CT Band 2		0, 3, 4, 5-8		0.00
LDNO HV: Non-Domestic Aggregated or CT Band 3		0, 3, 4, 5-8		0.00
LDNO HV: Non-Domestic Aggregated or CT Band 4		0, 3, 4, 5-8		0.00
LDNO HV: LV Site Specific No Residual		0		0.00
LDNO HV: LV Site Specific Band 1		0		0.00
LDNO HV: LV Site Specific Band 2		0		0.00
LDNO HV: LV Site Specific Band 3		0		0.00
LDNO HV: LV Site Specific Band 4		0		0.00
LDNO HV: LV Sub Site Specific No Residual		0		0.00
LDNO HV: LV Sub Site Specific Band 1		0		0.00
LDNO HV: LV Sub Site Specific Band 2		0		0.00
LDNO HV: LV Sub Site Specific Band 3		0		0.00
LDNO HV: LV Sub Site Specific Band 4		0		0.00
LDNO HV: HV Site Specific No Residual		0		0.00
LDNO HV: HV Site Specific Band 1		0		0.00
LDNO HV: HV Site Specific Band 2		0		0.00

Tariff name	Open LLFCs / DUoS Tariff IDs / LDNO unique billing identifier	PCs	Supplier of Last Resort Fixed charge adder* p/MPAN/day	Eligible Bad Debt Fixed charge adder** p/MPAN/day
LDNO HV: HV Site Specific Band 3		0		0.00
LDNO HV: HV Site Specific Band 4		0		0.00
LDNO HVplus: Domestic Aggregated or CT with Residual		0, 1, 2	0.00	0.00
LDNO HVplus: Non-Domestic Aggregated or CT No Residual		0, 3, 4, 5-8		0.00
LDNO HVplus: Non-Domestic Aggregated or CT Band 1		0, 3, 4, 5-8		0.00
LDNO HVplus: Non-Domestic Aggregated or CT Band 2		0, 3, 4, 5-8		0.00
LDNO HVplus: Non-Domestic Aggregated or CT Band 3		0, 3, 4, 5-8		0.00
LDNO HVplus: Non-Domestic Aggregated or CT Band 4		0, 3, 4, 5-8		0.00
LDNO HVplus: LV Site Specific No Residual		0		0.00
LDNO HVplus: LV Site Specific Band 1		0		0.00
LDNO HVplus: LV Site Specific Band 2		0		0.00
LDNO HVplus: LV Site Specific Band 3		0		0.00
LDNO HVplus: LV Site Specific Band 4		0		0.00
LDNO HVplus: LV Sub Site Specific No Residual		0		0.00
LDNO HVplus: LV Sub Site Specific Band 1		0		0.00
LDNO HVplus: LV Sub Site Specific Band 2		0		0.00
LDNO HVplus: LV Sub Site Specific Band 3		0		0.00
LDNO HVplus: LV Sub Site Specific Band 4		0		0.00
LDNO HVplus: HV Site Specific No Residual		0		0.00
LDNO HVplus: HV Site Specific Band 1		0		0.00
LDNO HVplus: HV Site Specific Band 2		0		0.00
LDNO HVplus: HV Site Specific Band 3		0		0.00
LDNO HVplus: HV Site Specific Band 4		0		0.00
LDNO EHV: Domestic Aggregated or CT with Residual		0, 1, 2	0.00	0.00
LDNO EHV: Non-Domestic Aggregated or CT No Residual		0, 3, 4, 5-8		0.00
LDNO EHV: Non-Domestic Aggregated or CT Band 1		0, 3, 4, 5-8		0.00
LDNO EHV: Non-Domestic Aggregated or CT Band 2		0, 3, 4, 5-8		0.00
LDNO EHV: Non-Domestic Aggregated or CT Band 3		0, 3, 4, 5-8		0.00

Tariff name	Open LLFCs / DUoS Tariff IDs / LDNO unique billing identifier	PCs	Supplier of Last Resort Fixed charge adder* p/MPAN/day	Eligible Bad Debt Fixed charge adder** p/MPAN/day
LDNO EHV: Non-Domestic Aggregated or CT Band 4		0, 3, 4, 5-8		0.00
LDNO EHV: LV Site Specific No Residual		0		0.00
LDNO EHV: LV Site Specific Band 1		0		0.00
LDNO EHV: LV Site Specific Band 2		0		0.00
LDNO EHV: LV Site Specific Band 3		0		0.00
LDNO EHV: LV Site Specific Band 4		0		0.00
LDNO EHV: LV Sub Site Specific No Residual		0		0.00
LDNO EHV: LV Sub Site Specific Band 1		0		0.00
LDNO EHV: LV Sub Site Specific Band 2		0		0.00
LDNO EHV: LV Sub Site Specific Band 3		0		0.00
LDNO EHV: LV Sub Site Specific Band 4		0		0.00
LDNO EHV: HV Site Specific No Residual		0		0.00
LDNO EHV: HV Site Specific Band 1		0		0.00
LDNO EHV: HV Site Specific Band 2		0		0.00
LDNO EHV: HV Site Specific Band 3		0		0.00
LDNO EHV: HV Site Specific Band 4		0		0.00
LDNO 132kV/EHV: Domestic Aggregated or CT with Residual		0, 1, 2	0.00	0.00
LDNO 132kV/EHV: Non-Domestic Aggregated or CT No Residual		0, 3, 4, 5-8		0.00
LDNO 132kV/EHV: Non-Domestic Aggregated or CT Band 1		0, 3, 4, 5-8		0.00
LDNO 132kV/EHV: Non-Domestic Aggregated or CT Band 2		0, 3, 4, 5-8		0.00
LDNO 132kV/EHV: Non-Domestic Aggregated or CT Band 3		0, 3, 4, 5-8		0.00
LDNO 132kV/EHV: Non-Domestic Aggregated or CT Band 4		0, 3, 4, 5-8		0.00
LDNO 132kV/EHV: LV Site Specific No Residual		0		0.00
LDNO 132kV/EHV: LV Site Specific Band 1		0		0.00
LDNO 132kV/EHV: LV Site Specific Band 2		0		0.00
LDNO 132kV/EHV: LV Site Specific Band 3		0		0.00
LDNO 132kV/EHV: LV Site Specific Band 4		0		0.00
LDNO 132kV/EHV: LV Sub Site Specific No Residual		0		0.00
LDNO 132kV/EHV: LV Sub Site Specific Band 1		0		0.00
LDNO 132kV/EHV: LV Sub Site Specific Band 2		0		0.00

Tariff name	Open LLFCs / DUoS Tariff IDs / LDNO unique billing identifier	PCs	Supplier of Last Resort Fixed charge adder* p/MPAN/day	Eligible Bad Debt Fixed charge adder** p/MPAN/day
LDNO 132kV/EHV: LV Sub Site Specific Band 3		0		0.00
LDNO 132kV/EHV: LV Sub Site Specific Band 4		0		0.00
LDNO 132kV/EHV: HV Site Specific No Residual		0		0.00
LDNO 132kV/EHV: HV Site Specific Band 1		0		0.00
LDNO 132kV/EHV: HV Site Specific Band 2		0		0.00
LDNO 132kV/EHV: HV Site Specific Band 3		0		0.00
LDNO 132kV/EHV: HV Site Specific Band 4		0		0.00
LDNO 132kV: Domestic Aggregated or CT with Residual		0, 1, 2	0.00	0.00
LDNO 132kV: Non-Domestic Aggregated or CT No Residual		0, 3, 4, 5-8		0.00
LDNO 132kV: Non-Domestic Aggregated or CT Band 1		0, 3, 4, 5-8		0.00
LDNO 132kV: Non-Domestic Aggregated or CT Band 2		0, 3, 4, 5-8		0.00
LDNO 132kV: Non-Domestic Aggregated or CT Band 3		0, 3, 4, 5-8		0.00
LDNO 132kV: Non-Domestic Aggregated or CT Band 4		0, 3, 4, 5-8		0.00
LDNO 132kV: LV Site Specific No Residual		0		0.00
LDNO 132kV: LV Site Specific Band 1		0		0.00
LDNO 132kV: LV Site Specific Band 2		0		0.00
LDNO 132kV: LV Site Specific Band 3		0		0.00
LDNO 132kV: LV Site Specific Band 4		0		0.00
LDNO 132kV: LV Sub Site Specific No Residual		0		0.00
LDNO 132kV: LV Sub Site Specific Band 1		0		0.00
LDNO 132kV: LV Sub Site Specific Band 2		0		0.00
LDNO 132kV: LV Sub Site Specific Band 3		0		0.00
LDNO 132kV: LV Sub Site Specific Band 4		0		0.00
LDNO 132kV: HV Site Specific No Residual		0		0.00
LDNO 132kV: HV Site Specific Band 1		0		0.00
LDNO 132kV: HV Site Specific Band 2		0		0.00
LDNO 132kV: HV Site Specific Band 3		0		0.00
LDNO 132kV: HV Site Specific Band 4		0		0.00
LDNO 0000: Domestic Aggregated or CT with Residual		0, 1, 2	0.00	0.00
LDNO 0000: Non-Domestic Aggregated or CT No Residual		0, 3, 4, 5-8		0.00

Tariff name	Open LLFCs / DUoS Tariff IDs / LDNO unique billing identifier	PCs	Supplier of Last Resort Fixed charge adder* p/MPAN/day	Eligible Bad Debt Fixed charge adder** p/MPAN/day
LDNO 0000: Non-Domestic Aggregated or CT Band 1		0, 3, 4, 5-8		0.00
LDNO 0000: Non-Domestic Aggregated or CT Band 2		0, 3, 4, 5-8		0.00
LDNO 0000: Non-Domestic Aggregated or CT Band 3		0, 3, 4, 5-8		0.00
LDNO 0000: Non-Domestic Aggregated or CT Band 4		0, 3, 4, 5-8		0.00
LDNO 0000: LV Site Specific No Residual		0		0.00
LDNO 0000: LV Site Specific Band 1		0		0.00
LDNO 0000: LV Site Specific Band 2		0		0.00
LDNO 0000: LV Site Specific Band 3		0		0.00
LDNO 0000: LV Site Specific Band 4		0		0.00
LDNO 0000: LV Sub Site Specific No Residual		0		0.00
LDNO 0000: LV Sub Site Specific Band 1		0		0.00
LDNO 0000: LV Sub Site Specific Band 2		0		0.00
LDNO 0000: LV Sub Site Specific Band 3		0		0.00
LDNO 0000: LV Sub Site Specific Band 4		0		0.00
LDNO 0000: HV Site Specific No Residual		0		0.00
LDNO 0000: HV Site Specific Band 1		0		0.00
LDNO 0000: HV Site Specific Band 2		0		0.00
LDNO 0000: HV Site Specific Band 3		0		0.00
LDNO 0000: HV Site Specific Band 4		0		0.00

## Annex 7 – Supplier of last Resort and Eligible Bad Debt Pass-Through Costs in “Northern Powergrid (Yorkshire) Area (GSP Group \_M)”

Southern Electric Power Distribution plc - Effective from 1 April 2027 - Final Supplier of Last Resort and Eligible Bad Debt Pass-Through Costs in NPG Yorkshire Area (GSP Group \_M)

Tariff name	Open LLFCs / DUoS Tariff IDs / LDNO unique billing identifier	PCs	Supplier of Last Resort Fixed charge adder* p/MPAN/day	Eligible Bad Debt Fixed charge adder** p/MPAN/day
Domestic Aggregated or CT with Residual	189, 391-392, 491-492, 522, MA0	0, 1, 2	0.00	0.00
Non-Domestic Aggregated or CT No Residual	M10, M15, M20, M30, M35, M45, M50, M55, R70, MA1	0, 3, 4, 5-8		0.00
Non-Domestic Aggregated or CT Band 1	M11, M16, M21, M31, M36, M46, M51, M56, R71, MA2	0, 3, 4, 5-8		0.00
Non-Domestic Aggregated or CT Band 2	M12, M17, M22, M32, M37, M47, M52, M57, R72, MA3	0, 3, 4, 5-8		0.00
Non-Domestic Aggregated or CT Band 3	M13, M18, M23, M33, M38, M48, M53, M58, R73, MA4	0, 3, 4, 5-8		0.00
Non-Domestic Aggregated or CT Band 4	M14, M19, M24, M34, M39, M49, M54, M59, R74, MA5	0, 3, 4, 5-8		0.00
LV Site Specific No Residual	M60, R65	0		0.00
LV Site Specific Band 1	M61, R66	0		0.00
LV Site Specific Band 2	M62, R67	0		0.00
LV Site Specific Band 3	M63, R68	0		0.00
LV Site Specific Band 4	M64, R69	0		0.00
LV Sub Site Specific No Residual	M40	0		0.00
LV Sub Site Specific Band 1	M41	0		0.00
LV Sub Site Specific Band 2	M42	0		0.00
LV Sub Site Specific Band 3	M43	0		0.00
LV Sub Site Specific Band 4	M44	0		0.00
HV Site Specific No Residual	M25	0		0.00
HV Site Specific Band 1	M26	0		0.00
HV Site Specific Band 2	M27	0		0.00

Tariff name	Open LLFCs / DUoS Tariff IDs / LDNO unique billing identifier	PCs	Supplier of Last Resort Fixed charge adder* p/MPAN/day	Eligible Bad Debt Fixed charge adder** p/MPAN/day
HV Site Specific Band 3	M28	0		0.00
HV Site Specific Band 4	M29	0		0.00
LDNO LV: Domestic Aggregated or CT with Residual		0, 1, 2	0.00	0.00
LDNO LV: Non-Domestic Aggregated or CT No Residual		0, 3, 4, 5-8		0.00
LDNO LV: Non-Domestic Aggregated or CT Band 1		0, 3, 4, 5-8		0.00
LDNO LV: Non-Domestic Aggregated or CT Band 2		0, 3, 4, 5-8		0.00
LDNO LV: Non-Domestic Aggregated or CT Band 3		0, 3, 4, 5-8		0.00
LDNO LV: Non-Domestic Aggregated or CT Band 4		0, 3, 4, 5-8		0.00
LDNO LV: LV Site Specific No Residual		0		0.00
LDNO LV: LV Site Specific Band 1		0		0.00
LDNO LV: LV Site Specific Band 2		0		0.00
LDNO LV: LV Site Specific Band 3		0		0.00
LDNO LV: LV Site Specific Band 4		0		0.00
LDNO HV: Domestic Aggregated or CT with Residual		0, 1, 2	0.00	0.00
LDNO HV: Non-Domestic Aggregated or CT No Residual		0, 3, 4, 5-8		0.00
LDNO HV: Non-Domestic Aggregated or CT Band 1		0, 3, 4, 5-8		0.00
LDNO HV: Non-Domestic Aggregated or CT Band 2		0, 3, 4, 5-8		0.00
LDNO HV: Non-Domestic Aggregated or CT Band 3		0, 3, 4, 5-8		0.00
LDNO HV: Non-Domestic Aggregated or CT Band 4		0, 3, 4, 5-8		0.00
LDNO HV: LV Site Specific No Residual		0		0.00
LDNO HV: LV Site Specific Band 1		0		0.00
LDNO HV: LV Site Specific Band 2		0		0.00
LDNO HV: LV Site Specific Band 3		0		0.00
LDNO HV: LV Site Specific Band 4		0		0.00
LDNO HV: LV Sub Site Specific No Residual		0		0.00
LDNO HV: LV Sub Site Specific Band 1		0		0.00
LDNO HV: LV Sub Site Specific Band 2		0		0.00

Tariff name	Open LLCs / DUoS Tariff IDs / LDNO unique billing identifier	PCs	Supplier of Last Resort Fixed charge adder* p/MPAN/day	Eligible Bad Debt Fixed charge adder** p/MPAN/day
LDNO HV: LV Sub Site Specific Band 3		0		0.00
LDNO HV: LV Sub Site Specific Band 4		0		0.00
LDNO HV: HV Site Specific No Residual		0		0.00
LDNO HV: HV Site Specific Band 1		0		0.00
LDNO HV: HV Site Specific Band 2		0		0.00
LDNO HV: HV Site Specific Band 3		0		0.00
LDNO HV: HV Site Specific Band 4		0		0.00
LDNO HVplus: Domestic Aggregated or CT with Residual		0, 1, 2	0.00	0.00
LDNO HVplus: Non-Domestic Aggregated or CT No Residual		0, 3, 4, 5-8		0.00
LDNO HVplus: Non-Domestic Aggregated or CT Band 1		0, 3, 4, 5-8		0.00
LDNO HVplus: Non-Domestic Aggregated or CT Band 2		0, 3, 4, 5-8		0.00
LDNO HVplus: Non-Domestic Aggregated or CT Band 3		0, 3, 4, 5-8		0.00
LDNO HVplus: Non-Domestic Aggregated or CT Band 4		0, 3, 4, 5-8		0.00
LDNO HVplus: LV Site Specific No Residual		0		0.00
LDNO HVplus: LV Site Specific Band 1		0		0.00
LDNO HVplus: LV Site Specific Band 2		0		0.00
LDNO HVplus: LV Site Specific Band 3		0		0.00
LDNO HVplus: LV Site Specific Band 4		0		0.00
LDNO HVplus: LV Sub Site Specific No Residual		0		0.00
LDNO HVplus: LV Sub Site Specific Band 1		0		0.00
LDNO HVplus: LV Sub Site Specific Band 2		0		0.00
LDNO HVplus: LV Sub Site Specific Band 3		0		0.00
LDNO HVplus: LV Sub Site Specific Band 4		0		0.00
LDNO HVplus: HV Site Specific No Residual		0		0.00
LDNO HVplus: HV Site Specific Band 1		0		0.00
LDNO HVplus: HV Site Specific Band 2		0		0.00
LDNO HVplus: HV Site Specific Band 3		0		0.00
LDNO HVplus: HV Site Specific Band 4		0		0.00
LDNO EHV: Domestic Aggregated or CT with Residual		0, 1, 2	0.00	0.00
LDNO EHV: Non-Domestic Aggregated or CT No Residual		0, 3, 4, 5-8		0.00

Tariff name	Open LLCs / DUoS Tariff IDs / LDNO unique billing identifier	PCs	Supplier of Last Resort Fixed charge adder* p/MPAN/day	Eligible Bad Debt Fixed charge adder** p/MPAN/day
LDNO EHV: Non-Domestic Aggregated or CT Band 1		0, 3, 4, 5-8		0.00
LDNO EHV: Non-Domestic Aggregated or CT Band 2		0, 3, 4, 5-8		0.00
LDNO EHV: Non-Domestic Aggregated or CT Band 3		0, 3, 4, 5-8		0.00
LDNO EHV: Non-Domestic Aggregated or CT Band 4		0, 3, 4, 5-8		0.00
LDNO EHV: LV Site Specific No Residual		0		0.00
LDNO EHV: LV Site Specific Band 1		0		0.00
LDNO EHV: LV Site Specific Band 2		0		0.00
LDNO EHV: LV Site Specific Band 3		0		0.00
LDNO EHV: LV Site Specific Band 4		0		0.00
LDNO EHV: LV Sub Site Specific No Residual		0		0.00
LDNO EHV: LV Sub Site Specific Band 1		0		0.00
LDNO EHV: LV Sub Site Specific Band 2		0		0.00
LDNO EHV: LV Sub Site Specific Band 3		0		0.00
LDNO EHV: LV Sub Site Specific Band 4		0		0.00
LDNO EHV: HV Site Specific No Residual		0		0.00
LDNO EHV: HV Site Specific Band 1		0		0.00
LDNO EHV: HV Site Specific Band 2		0		0.00
LDNO EHV: HV Site Specific Band 3		0		0.00
LDNO EHV: HV Site Specific Band 4		0		0.00
LDNO 132kV/EHV: Domestic Aggregated or CT with Residual		0, 1, 2	0.00	0.00
LDNO 132kV/EHV: Non-Domestic Aggregated or CT No Residual		0, 3, 4, 5-8		0.00
LDNO 132kV/EHV: Non-Domestic Aggregated or CT Band 1		0, 3, 4, 5-8		0.00
LDNO 132kV/EHV: Non-Domestic Aggregated or CT Band 2		0, 3, 4, 5-8		0.00
LDNO 132kV/EHV: Non-Domestic Aggregated or CT Band 3		0, 3, 4, 5-8		0.00
LDNO 132kV/EHV: Non-Domestic Aggregated or CT Band 4		0, 3, 4, 5-8		0.00
LDNO 132kV/EHV: LV Site Specific No Residual		0		0.00
LDNO 132kV/EHV: LV Site Specific Band 1		0		0.00
LDNO 132kV/EHV: LV Site Specific Band 2		0		0.00

Tariff name	Open LLFCs / DUoS Tariff IDs / LDNO unique billing identifier	PCs	Supplier of Last Resort Fixed charge adder* p/MPAN/day	Eligible Bad Debt Fixed charge adder** p/MPAN/day
LDNO 132kV/EHV: LV Site Specific Band 3		0		0.00
LDNO 132kV/EHV: LV Site Specific Band 4		0		0.00
LDNO 132kV/EHV: LV Sub Site Specific No Residual		0		0.00
LDNO 132kV/EHV: LV Sub Site Specific Band 1		0		0.00
LDNO 132kV/EHV: LV Sub Site Specific Band 2		0		0.00
LDNO 132kV/EHV: LV Sub Site Specific Band 3		0		0.00
LDNO 132kV/EHV: LV Sub Site Specific Band 4		0		0.00
LDNO 132kV/EHV: HV Site Specific No Residual		0		0.00
LDNO 132kV/EHV: HV Site Specific Band 1		0		0.00
LDNO 132kV/EHV: HV Site Specific Band 2		0		0.00
LDNO 132kV/EHV: HV Site Specific Band 3		0		0.00
LDNO 132kV/EHV: HV Site Specific Band 4		0		0.00
LDNO 132kV: Domestic Aggregated or CT with Residual		0, 1, 2	0.00	0.00
LDNO 132kV: Non-Domestic Aggregated or CT No Residual		0, 3, 4, 5-8		0.00
LDNO 132kV: Non-Domestic Aggregated or CT Band 1		0, 3, 4, 5-8		0.00
LDNO 132kV: Non-Domestic Aggregated or CT Band 2		0, 3, 4, 5-8		0.00
LDNO 132kV: Non-Domestic Aggregated or CT Band 3		0, 3, 4, 5-8		0.00
LDNO 132kV: Non-Domestic Aggregated or CT Band 4		0, 3, 4, 5-8		0.00
LDNO 132kV: LV Site Specific No Residual		0		0.00
LDNO 132kV: LV Site Specific Band 1		0		0.00
LDNO 132kV: LV Site Specific Band 2		0		0.00
LDNO 132kV: LV Site Specific Band 3		0		0.00
LDNO 132kV: LV Site Specific Band 4		0		0.00
LDNO 132kV: LV Sub Site Specific No Residual		0		0.00
LDNO 132kV: LV Sub Site Specific Band 1		0		0.00
LDNO 132kV: LV Sub Site Specific Band 2		0		0.00
LDNO 132kV: LV Sub Site Specific Band 3		0		0.00
LDNO 132kV: LV Sub Site Specific Band 4		0		0.00
LDNO 132kV: HV Site Specific No Residual		0		0.00
LDNO 132kV: HV Site Specific Band 1		0		0.00
LDNO 132kV: HV Site Specific Band 2		0		0.00

Tariff name	Open LLFCs / DUoS Tariff IDs / LDNO unique billing identifier	PCs	Supplier of Last Resort Fixed charge adder* p/MPAN/day	Eligible Bad Debt Fixed charge adder** p/MPAN/day
LDNO 132kV: HV Site Specific Band 3		0		0.00
LDNO 132kV: HV Site Specific Band 4		0		0.00
LDNO 0000: Domestic Aggregated or CT with Residual		0, 1, 2	0.00	0.00
LDNO 0000: Non-Domestic Aggregated or CT No Residual		0, 3, 4, 5-8		0.00
LDNO 0000: Non-Domestic Aggregated or CT Band 1		0, 3, 4, 5-8		0.00
LDNO 0000: Non-Domestic Aggregated or CT Band 2		0, 3, 4, 5-8		0.00
LDNO 0000: Non-Domestic Aggregated or CT Band 3		0, 3, 4, 5-8		0.00
LDNO 0000: Non-Domestic Aggregated or CT Band 4		0, 3, 4, 5-8		0.00
LDNO 0000: LV Site Specific No Residual		0		0.00
LDNO 0000: LV Site Specific Band 1		0		0.00
LDNO 0000: LV Site Specific Band 2		0		0.00
LDNO 0000: LV Site Specific Band 3		0		0.00
LDNO 0000: LV Site Specific Band 4		0		0.00
LDNO 0000: LV Sub Site Specific No Residual		0		0.00
LDNO 0000: LV Sub Site Specific Band 1		0		0.00
LDNO 0000: LV Sub Site Specific Band 2		0		0.00
LDNO 0000: LV Sub Site Specific Band 3		0		0.00
LDNO 0000: LV Sub Site Specific Band 4		0		0.00
LDNO 0000: HV Site Specific No Residual		0		0.00
LDNO 0000: HV Site Specific Band 1		0		0.00
LDNO 0000: HV Site Specific Band 2		0		0.00
LDNO 0000: HV Site Specific Band 3		0		0.00
LDNO 0000: HV Site Specific Band 4		0		0.00

\*Supplier of Last Resort pass-through costs allocated to all domestic tariffs with a fixed charge (including LDNO)

\*\*Eligible Bad Debt pass-through costs allocated to all metered demand tariffs (including LDNO)