

MINETY GRID SUPPLY POINT: STRATEGIC DEVELOPMENT PLAN

Our network serving communities across Swindon and Cotswold

Final Publication

February 2026



CONTENTS

1. Executive Summary	4
2. Introduction	6
3. Stakeholder Engagement and Whole System Considerations	8
3.1. Local Authorities and Local Area Energy Planning	8
3.1.1. Cotswold	9
3.1.2. Swindon	9
3.1.3. Vale of White Horse	9
3.1.4. Oxfordshire County Council	10
3.1.5. Wiltshire Council	11
3.1.6. West Oxfordshire County Council	11
3.2. Whole System Considerations	12
3.2.1. Transmission interactions	12
3.2.2. Flexibility Considerations	12
4. Existing Network Infrastructure	14
4.1. Minety Grid Supply Point Context	14
4.2. Current Network Topology	15
4.3. Current Network Schematic	16
5. Future electricity load at Minety GSP	17
5.1. Generation and Storage	17
5.1.1. Distributed Energy Resources (DER)	17
5.2. Transport Electrification	20
5.3. Electrification of heat	21
5.4. New building developments	21
5.5. Commercial and industrial electrification	23
5.5.1. Agricultural Decarbonisation	23
6. Work in progress	24
6.1. Network Schematic (following completion of above works)	27
7. Spatial plans of future needs	28
7.1. Extra High Voltage / High Voltage spatial plans	28
7.2. HV/LV spatial plans	29
8. Specific system needs and options to resolve	30
8.1.1. Overall dependencies, risks, and mitigations	30
8.2. Future EHV System Needs ahead of 2035	30
8.3. Future EHV System Needs to 2050	35
8.4. Future requirements of the High Voltage and Low Voltage Networks	38



8.4.1. High Voltage Networks	38
8.4.2. Low Voltage Networks	41
9. Recommendations	43



1. EXECUTIVE SUMMARY

SSEN is taking a strategic approach in the development of its distribution networks. This will help to enable the net zero transition at a local level to the homes, businesses, and communities we serve. Our Strategic Development Plans (SDPs) take the feedback we have received from stakeholders on their future energy needs from today out to 2050 and translate these requirements into strategic spatial plans of distribution network needs. This helps us transparently present our future conceptual plans and facilitate discussion with local authorities and other stakeholders. The overall methodology and how it fits into our wider strategic planning process is presented in the [Strategic Development Plan methodology](#). The focus area of this SDP is the area that is supplied by Minety Grid Supply Point (GSP), shown below in Figure 1.

This report documents the stakeholder led plans that are driving net zero and growth in the local area, the resulting electricity demands, and the network needs arising from this. Plans across Swindon, Vale of White Horse, Cotswold, Wiltshire, Oxfordshire County Council and West Oxfordshire District Council have been considered in preparation for this plan. Some reinforcement work has been triggered in this area through the Distribution Network Options Assessment (DNOA) process.

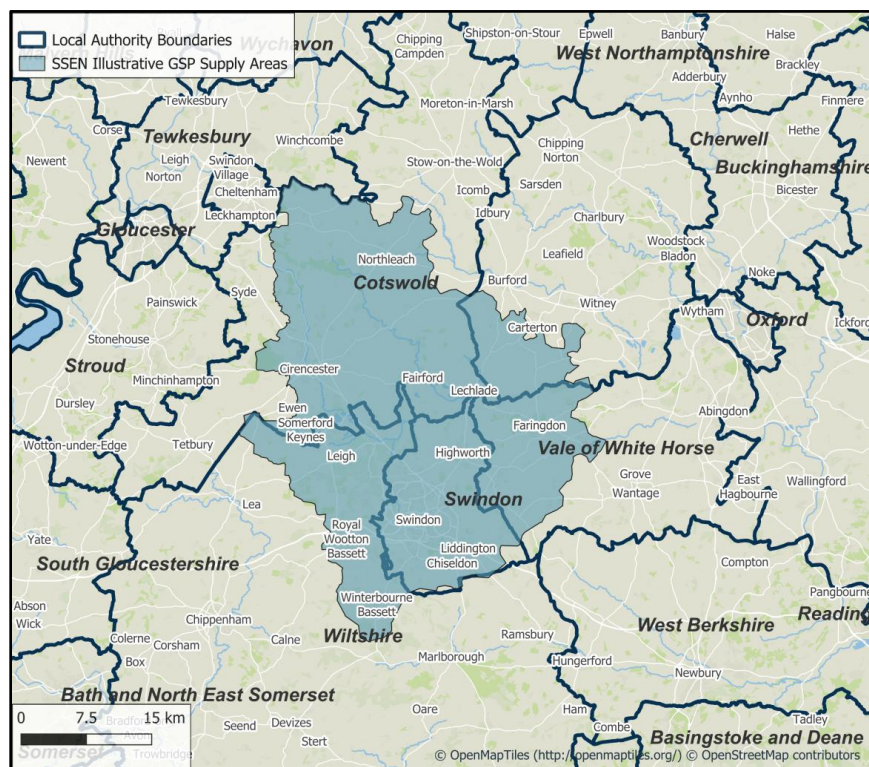

Figure 1 Area of focus for this SDP.

This report documents the stakeholder led plans that are driving net zero and growth in the local area, the resulting electricity demands, and the network needs arising from this. Plans across Vale of White Horse, Minety Grid Supply Point: Strategic Development Plan



Swindon, Cotswold, Wiltshire, West Oxfordshire and Oxfordshire County Councils have been considered in preparation for this plan.

This SDP utilises the Distribution Future Energy Scenarios (DFES) to understand the pathways to a 2050 network that can support net zero and growth in the local economy. Recommendations from this report outline the initial steps that we believe should be taken on that pathway to develop the network in an efficient and stakeholder-led way.



2. INTRODUCTION

The aim of this report is to demonstrate how local, regional, and national targets align with stakeholder ambitions in the area to provide a robust evidence base for load growth out to 2050 across the area served by Minety Grid Supply Point (GSP). A GSP is an interface point with the national transmission system where SSEN Distribution then takes power to local homes and businesses within a geographic area. Context for the area this represents is shown above in Figure 1.

To identify the future requirements of the electricity network, SSEN commissions Regen to produce the annual Distribution Future Energy Scenarios (DFES). The DFES analysis is based on the National Energy System Operator (NESO) Future Energy Scenarios (FES), while incorporating more granular stakeholder insights from agencies such as local authorities and new demand and generation connection applications. The DFES provides a forward-looking view of how demand and generation may evolve under different scenarios as we move towards the national 2050 net zero target. These scenarios are summarised in Figure 2. SSEN uses Holistic Transition as the central case scenario, reviewing this position annually. Any more recent unforeseen demand changes, for example customer connection requests, are also considered in our forecasts to ensure that the projected load more accurately reflects what we expect to see in the future.

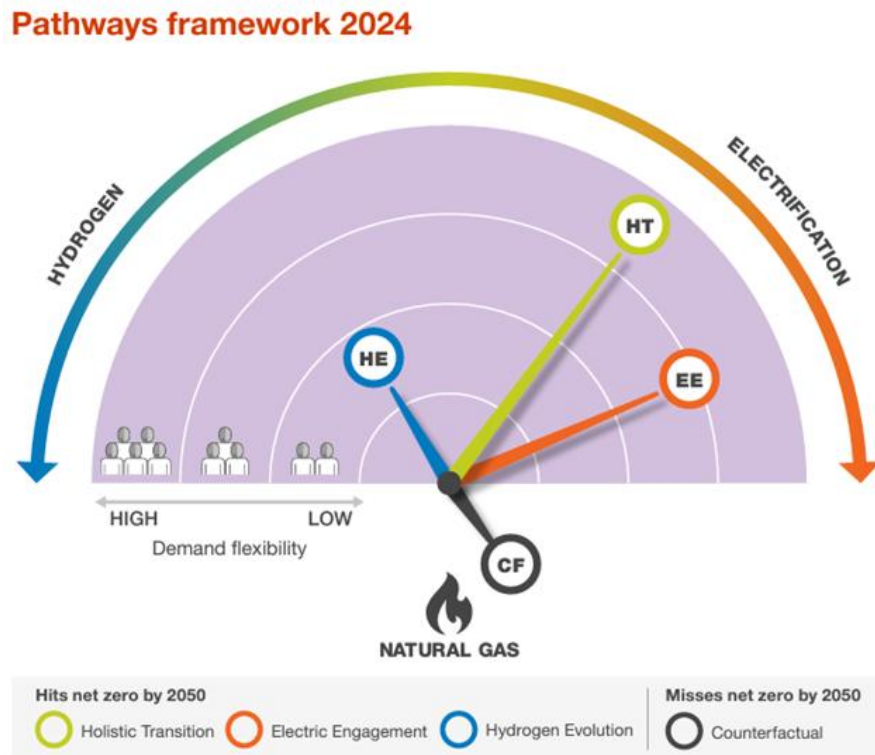

Figure 2 The FES Scenario framework (source: NESO)

Using the DFES, power system analysis has been carried out to identify the future system needs of the electricity network. These needs are summarised by highlighting the year the need is identified under each of the scenarios, and the projected 2050 load. We model across the other scenarios alongside Holistic Transition to



understand when these needs could arise and what network capacity should be planned for in the event each scenario is realised.

The DNOA process provides more detailed optioneering for each of these system needs, improving stakeholder visibility of the strategic planning process. Opportunities for the procurement of flexibility are also highlighted in the DNOA to cultivate the flexibility markets.

Further information on the FES framework can be found in the [DFES 2024 introductory report](#).



3. STAKEHOLDER ENGAGEMENT AND WHOLE SYSTEM CONSIDERATIONS

3.1. Local Authorities and Local Area Energy Planning

The local authorities that are supplied by Minety GSP include Cotswold, Swindon, Vale of White Horse, Wiltshire and West Oxfordshire district council as shown in Figure 3. These areas also fall within the administrative boundary of Oxfordshire County Council, highlighting the broader regional impact of the GSP. The development plans for these local authorities will have a significant impact on the potential future electricity load growth on SSEN’s distribution network. As such, it is vital for SSEN to engage with these plans when carrying out strategic network investment.

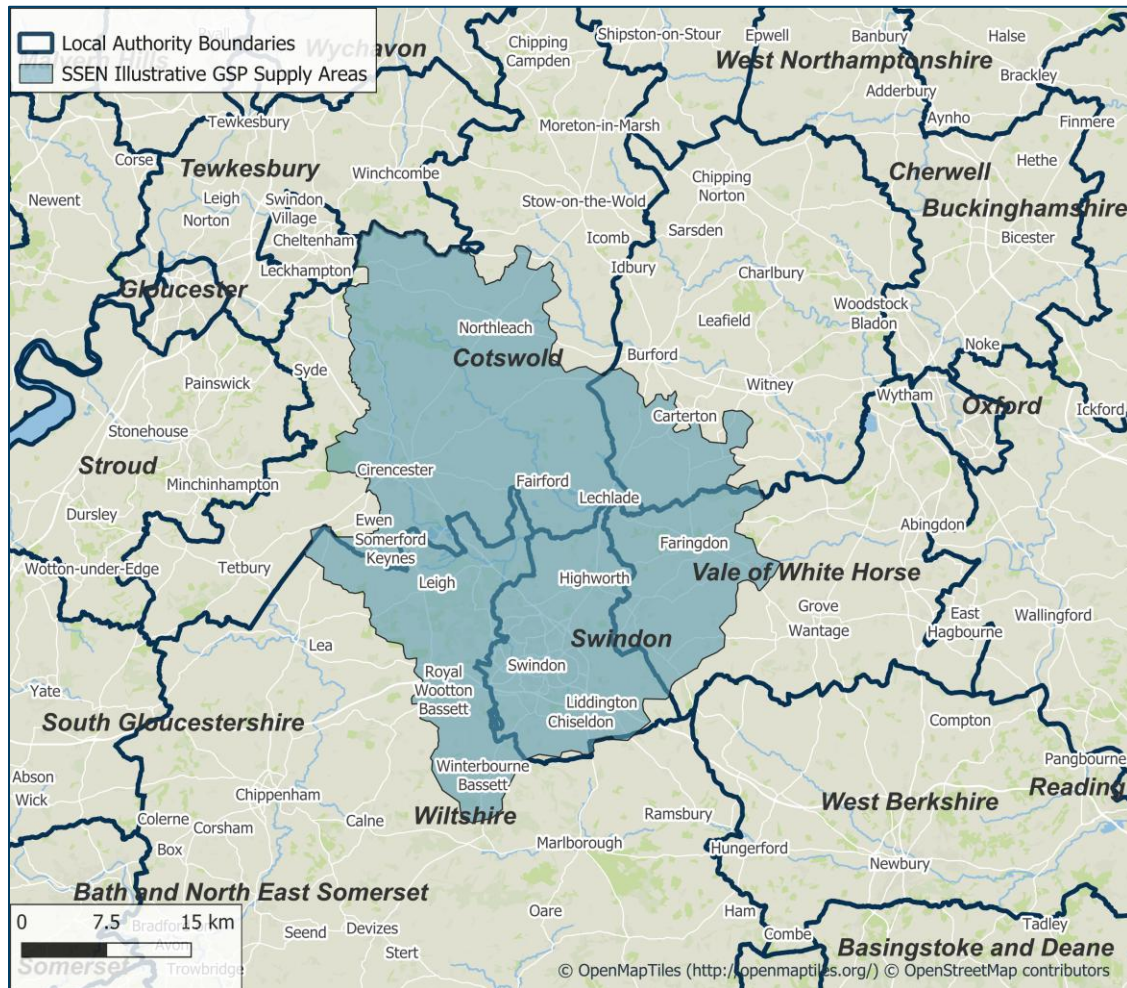

Figure 3 Minety GSP supply area and local authority boundaries



3.1.1. Cotswold

Cotswold District Council has seen population growth of 9.6% from around 82,900 in 2011 to around 90,800 in 2021¹. To meet the expected growth in population a target of building 836 additional new homes between 2022-2031 has been set². Gloucestershire County Council aims for the county to reach net zero by 2045³, a number of schemes are being run across the county and district level to support this. Gloucestershire council with 10 key areas highlighted to support this, such as plans to install 1,000 electric vehicle charge points by 2025 and support residential electrification of heat through a home upgrade grant⁴ running until March 2025 for off-gas, low-income homes throughout Gloucestershire. In April 2022, Cotswold District Council launched a Climate Investment Programme that raised £500,000 to roll out electric vehicle charge points and install solar PV, along with other initiatives⁵.

To support delivery, the council has launched targeted investment programmes such as the [Climate Investment Programme](#), which raised £500,000 in April 2022 to accelerate deployment of EV charge points, rooftop solar PV and other local decarbonisation initiatives. These sit alongside wider strategic commitments set out in Cotswold District Council's Climate Emergency declaration (2019) and [Climate Emergency Strategy 2020–2030](#), which outline the council's net-zero objectives and actions across housing, transport, energy and land use. The ongoing [Local Plan](#) update seeks to embed these commitments by delivering net-zero-ready homes and enabling low-carbon transport, forming a coordinated framework to reduce emissions and support essential energy-infrastructure improvements across the district.

3.1.2. Swindon

Swindon Borough Council is currently developing a [new Local Plan](#) which sets out development to 2043 with a further view out to 2055. At present, they are out for consultation on the draft Plan until mid-October 2025. Within the draft plan, the Council notes the role the Planning system has to play in facilitating renewable energy generation in the area.

In July 2024, the [Swindon Plan](#) was approved which sets out three priority missions to 'Build a Fairer Swindon', 'Build a Better Swindon', and 'Build a Greener Swindon' and provide a performance tracker against each to demonstrate progress. Within the priority to 'Build a Greener Swindon', the objective is set to transition fleet and depot to net-zero carbon operations.

3.1.3. Vale of White Horse

1 Census 2021, January 2023, How life has changed in Cotswold: Census 2021.

2 [Annex A - draft Cotswold Housing Strategy - Technical consultation document.pdf](#)

3 [We will | Gloucestershire County Council](#)

4 [Home Upgrade Grant | Warm and Well](#)

5 [Cotswold Climate Investment - Cotswold District Council](#)
Minety Grid Supply Point: Strategic Development Plan



Vale of White Horse District Council has seen population growth of 14.8% from around 121,000 in 2011 to around 138,900 in 2021⁶. To meet the expected growth in population, in South Oxfordshire's and Vale of White Horse's Joint Local Plan 2041 (submitted for examination December 2024), the council has a target of building 14,490 new homes between 2021 and 2041. The Council has committed to becoming a carbon neutral organisation by 2030 and achieving net zero across the district by 2045. These goals are now embedded in the 2025–2029 Nature and Climate Action Plan (NCAP)⁷. The NCAP integrates climate and nature recovery efforts, recognising their interdependence, and outlines actions across five key themes: operational net zero, district net zero (via community engagement and partnerships), nature recovery, and climate adaptation⁸. The operational emissions of the Council have decreased by 49% since 2009 and is set to decrease further as a total of £6,354,662 in Public Sector Decarbonisation Scheme funding has been secured to decarbonise council buildings such as leisure centres⁹. Actions include installing EV charge points in council depots and other locations to meet the needs of the council's vehicle fleet, as well as a plan to install public EV charging points.

3.1.4. Oxfordshire County Council

Oxfordshire County Council declared a climate emergency in 2019 and has the ambition target of becoming carbon neutral by 2030. To help achieve this target the council annually publishes a review of its 'Carbon Management Plan'¹⁰ to ensure progress is up to date and new actions are identified. For the county's longer term targets, the Pathways to a Zero Carbon Oxfordshire Report 2021¹¹ and the Net Zero Route Map and Action Plan 2023¹² set out how the county at large could reach net zero by 2050 and factors in all the individual district level plans and targets. This analysis formed the basis for ongoing local area energy planning (OxLAEP) work currently being undertaken in the County. In addition to this, the council was also one of three that SSEN partnered with through the RESOP Project to trial LAEP+ (now LENZA)¹³.

The OxLAEP programme comprises the creation of 5 district level LAEPs + a county overview and builds the additional capacity and capability to conduct LAEP activities in-house in future years including the development of a delivery and financing plan. To support this SSEN is part of the OxLAEP governance structure as part of the Oxfordshire Leaders Joint Committee¹⁴, sitting on the Energy Planning Working Group and the Executive Steering Board to provide network insights. Recently the Government have established the Oxfordshire Growth Commission¹⁵ which is tasked with addressing key issues that are acting as a barrier to growth in the County, including the need for additional electricity network capacity especially affecting development around Oxford and Bicester.

6 [How life has changed in Vale of White Horse: Census 2021](#)

7 <https://www.southandvale.gov.uk/app/uploads/sites/3/2025/06/VOWH-SODC-Nature-and-Climate-Action-Plan-25-29.pdf>

8 [Vale-Climate-Action-plan-2022-2024.pdf](#)

9 [Microsoft Word - Greenhouse gas emissions report Vale 2023-24 final](#)

10 [Carbon Neutral by 2030 | Oxfordshire County Council](#)

11 [Pathways to a zero carbon Oxfordshire | Environmental Change Institute](#)

12 [Net Zero Route Map and Action Plan](#)

13 [LENZA - SSEN](#)

14 [Oxfordshire Leaders Joint Committee](#)

15 [Appointment of Oxford Growth Commission Chair - GOV.UK](#)
Minety Grid Supply Point: Strategic Development Plan



As well as the LAEP programme and the supporting OxLAEP governance structures there are several sector specific strategies that inform how electricity demand will increase across the council area. These include the Mobility Hub Strategy, the Rail Corridor Study, and the EV infrastructure Strategy.

3.1.5. Wiltshire Council

Wiltshire Council acknowledged a climate emergency in February 2019 and committed to becoming carbon neutral as an organisation by 2030. The council also committed to seeking to make the county of Wiltshire carbon neutral in the same timeframe. The council adopted its Climate Strategy in February 2022, which sets out objectives and ‘areas of focus’ to decrease greenhouse gas emissions and increase resilience to climate change for the county of Wiltshire for the period 2022 – 2027.

Delivery plans were put in place in 2022 to set out the steps towards implementation of the strategy. The Carbon Neutral Council Plan 2022-24 and the Climate Strategy Delivery Plan 2022-24 have been reviewed during 2024, both in terms of progress towards carbon reduction and climate adaptation outcomes and performance against the actions that the council committed to.

This plan now sets out the focus for the council’s action on climate change for 2025. Whilst this plan sets out priorities for one year, it also includes medium and longer-term implementation steps that will be necessary and puts this into context of where we are in relation to the long-term goals (pathways to Net Zero by 2050).

The Climate Strategy Objectives for a ‘Carbon Neutral Council’ are:

- To become carbon neutral as an organisation by 2030,
- Provide leadership locally and nationally, Wiltshire Council has committed to achieving carbon neutrality from our own operations by 2030, focusing on cutting direct emissions (Scope 1 and 2), and
- Tackling Scope 3 emissions by scrutinising our outsourced services and purchases.

3.1.6. West Oxfordshire District Council

West Oxfordshire District Council has seen population growth of 9% from just under 104,800 in 2011 to around 114,200 in 2021¹⁶. The council a target of delivering 1,210 homes a year from 2021-2031 and has adopted its’ Sustainability Standards Checklist¹⁷ in March 2024 for new developments, this ensures that net zero carbon goals are met through criteria such as ultra-low energy building fabric, fossil fuel free heating, and having set limits for embodied carbon emissions. Furthermore, the district council has made a commitment to becoming carbon-neutral by 2030 guided by its Carbon Action Plan¹⁸, agreed in 2020 (the latest version approved in 2024) which sets out several key targets. The council also has a shorter-term climate change strategy¹⁹ from 2021 to 2025 which includes policy such as continuing to support the development of Eynsham LAEP and delivering EV infrastructure across Council owned sites. As well as this, the council has also invested in low carbon

16 Census 2021, January 2023, How life has changed in West Oxfordshire: Census 2021.

17 [Sustainability Standards Checklist - West Oxfordshire District Council](#)

18 [Our route to carbon neutral - West Oxfordshire District Council](#)

19 [Climate change strategy - West Oxfordshire District Council](#)



infrastructure such as constructing six electric charging hubs²⁰ and providing a loan in 2020 to the Southill Solar Community Project²¹.

3.2. Whole System Considerations

The Swindon M4 Growth Zone, identified by the Swindon & Wiltshire Local Enterprise Partnership, is a strategic area of concentrated economic activity, leveraging Swindon's strengths in advanced manufacturing, commerce, and connectivity to attract investment and support sustainable industrial expansion²².

The Minety GSP region is undergoing a period of dynamic industrial growth, shaped by strategic infrastructure development and evolving economic priorities. Swindon, long known for its manufacturing and logistics base, is expanding into advanced technologies and green industries. The surrounding areas, including the Cotswolds and Vale of White Horse, are seeing increased investment in business parks, innovation hubs, and rural enterprise zones²³²⁴.

3.2.1. Transmission interactions

SSEN regularly engages with both National Grid Electricity Transmission (NGET) and the National Energy System Operator (NESO) to understand the interactions between the distribution and transmission networks in the area. Currently SSEN is working with NGET to release capacity at Minety GSP through regular meetings and working groups, with triggered works estimated for completion in 2036/37.

To support future reinforcement at Minety GSP, a new Super Grid Transformer (SGT) is planned for installation in 2031. To accommodate the associated transformer circuit breaker, a new (GIS) board will be required at Minety, which will be installed by SSEN. This infrastructure upgrade is a critical enabler for the long-term capacity release strategy and aligns with the collaborative planning efforts currently underway between SSEN and NGET. However, it should be noted that these projects may be subject to change due to the impact of connections reform and Clean Power 2030.

3.2.2. Flexibility Considerations

Flexibility services

SSEN procures Flexibility Services from owners, operators, or aggregators of Distributed Energy Resources (DERs) or Consumer Energy Resources (CERs), which can be generators, storage, or demand assets. These services are needed in areas of the network which have capacity constraints at particular times or under certain

²⁰ [Electric vehicle charging points - West Oxfordshire District Council](#)

²¹ [Renewable energy - West Oxfordshire District Council](#)

²² [Growth Zones in Swindon & Wiltshire | SWLEP](#)

²³ [Business in the Cotswolds is booming | Cotswold District Council News](#)

²⁴ [Science Vale and Enterprise Zones - Vale of White Horse District Council](#)
Minety Grid Supply Point: Strategic Development Plan



circumstances. SSEN purchases Flexibility Services from all types of providers (e.g. domestic or commercial). Information on the process for procurement and how to participate are published on the Flexibility Services website and information on real time decision making on which providers are dispatched can be found in the Operational Decision-Making document.^{25,26}

SSEN regularly recruits new Flexibility Services providers and increases the procured Flexibility Services with the latest bidding round for long term requirements held in May 2025 and recruitment through the Mini-Competition process most recently opening in mid-July 2025.²⁰

Areas across Minety GSP where flexibility has been procured is shown below in Figure 4. This map shows all Flexibility Services procured, which covers requirements beyond those identified for managing the deferral of reinforcement.

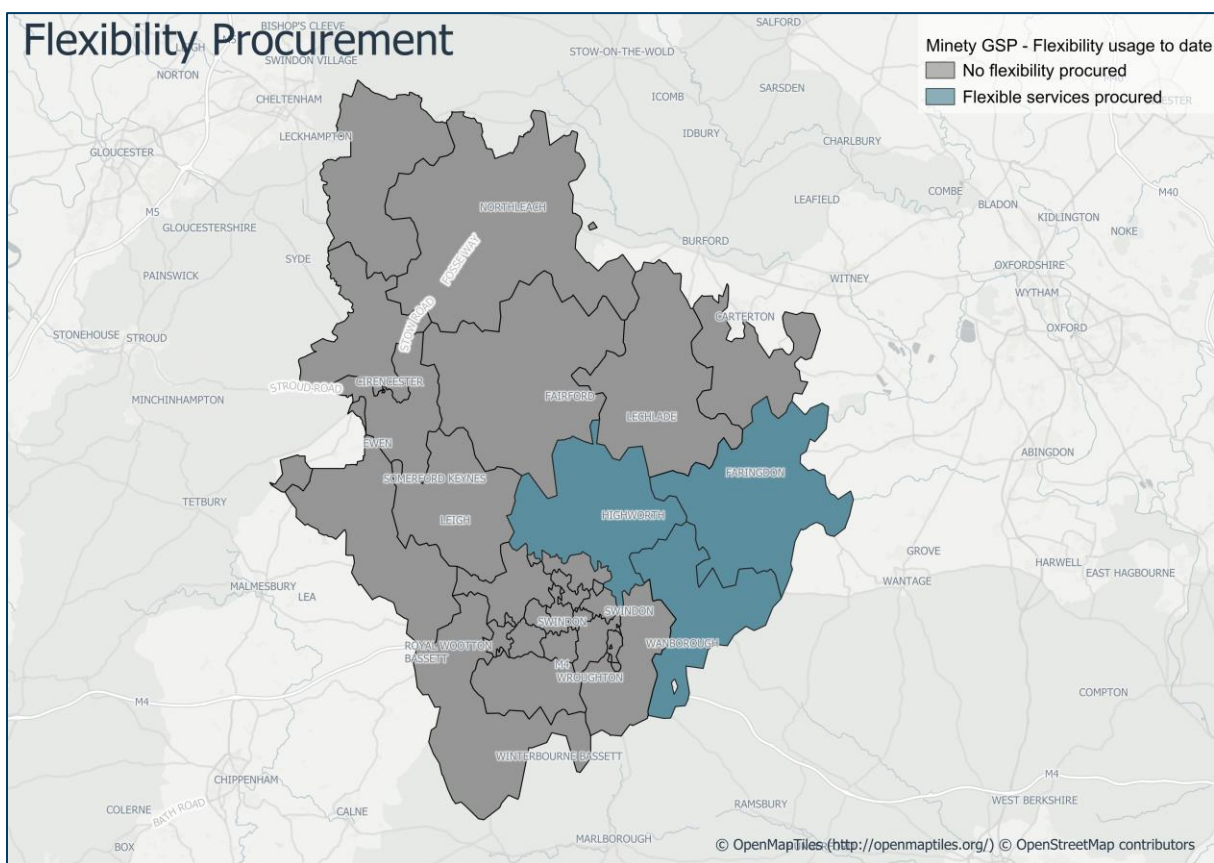

Figure 4 Flexibility procurement across Minety GSP

25 SSEN, Flexibility Services Procurement ([Flexibility Services Procurement - SSEN](#))

26 SSEN, 02/2024, Operational Decision Making (ODM), [SSEN Operational Decision Making ODM](#)
Minety Grid Supply Point: Strategic Development Plan



4. EXISTING NETWORK INFRASTRUCTURE

4.1. Minety Grid Supply Point Context

The Minety GSP network is made up of 132kV, 33kV, 11kV and LV circuits. It supplies a predominantly rural area, with some larger towns such as Swindon. In total, the GSP serves approximately 152,347 customers. Table 1 shows the values for the GSP, BSPs and PSSs supplied by the GSP (noting that some sites for single customers are not shown here).

The peak maximum demand refers to the peak at each individual substation which may not be at a coincident time as the others (meaning we would not expect the values for all bulk supply points substations to sum to that at the GSP). In the Minety region, a significant number of batteries are connected at the GSP level. As a result, the maximum demand recorded at the GSP exceeds the cumulative demand observed across the associated BSPs.

Substation Name	Site Type	Number of Customers Served (approximate)	2023/24 Substation Maximum demand in MVA (Winter)
Minety	GSP	152,347	349.53
CIRENCESTER BSP	BSP	28,401	54.25
STRATTON (2 X 60)	BSP	27,902	40.67
STRATTON (2 X 90)	BSP	25,048	44.26
SWINDON BSP	BSP	44,384	62.31
TOOTHILL BSP	BSP	23,081	43.34
GALILEO	PSS	3,531	13.81

Table 1 Customer number breakdown and substation peak demand readings (2023-2024)



4.2. Current Network Topology

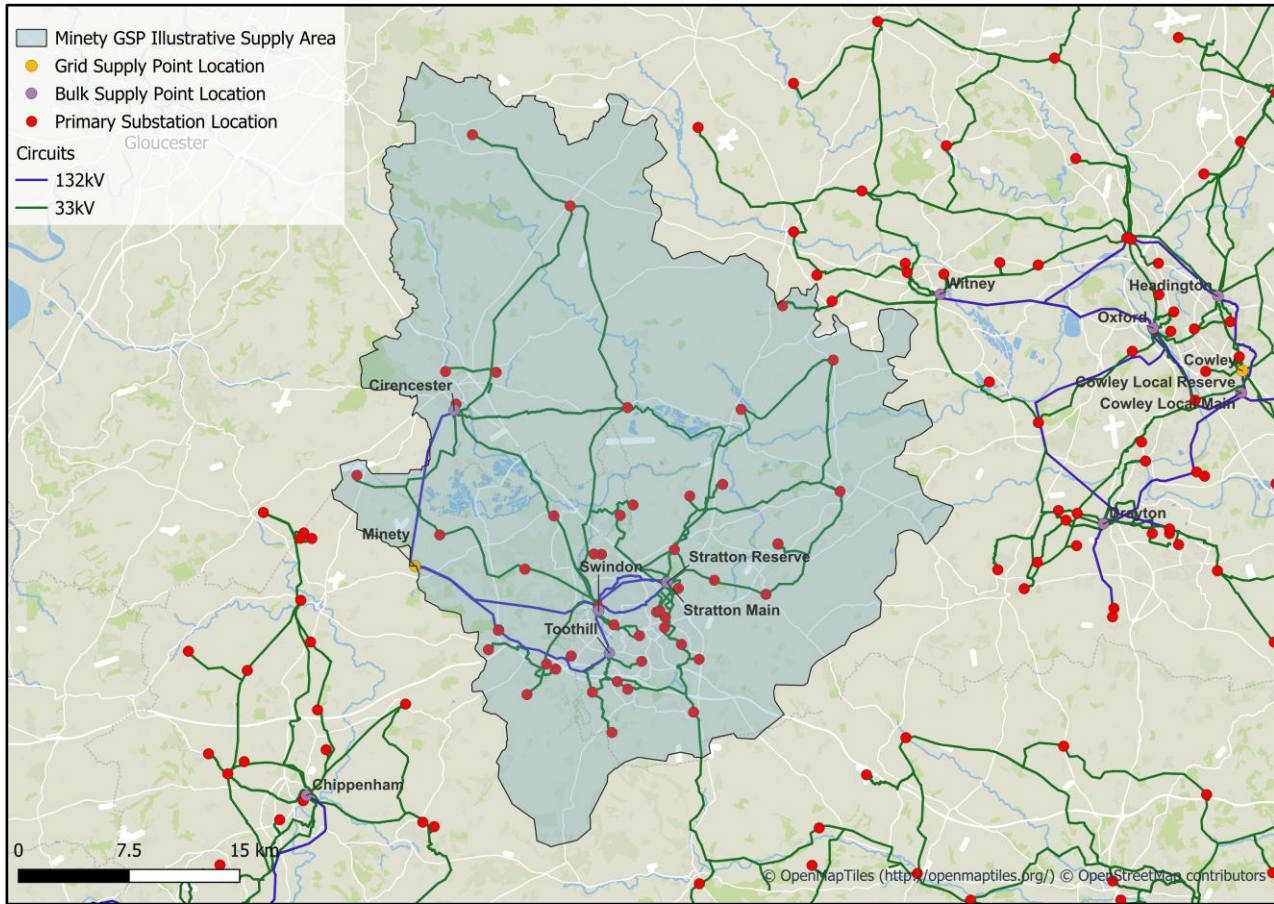

Figure 5 Current network topology of Minety GSP



4.3. Current Network Schematic

The existing 132kV network at Minety GSP is shown below in Figure 6. Additional schematics for the 33kV networks can be found in Appendix A.

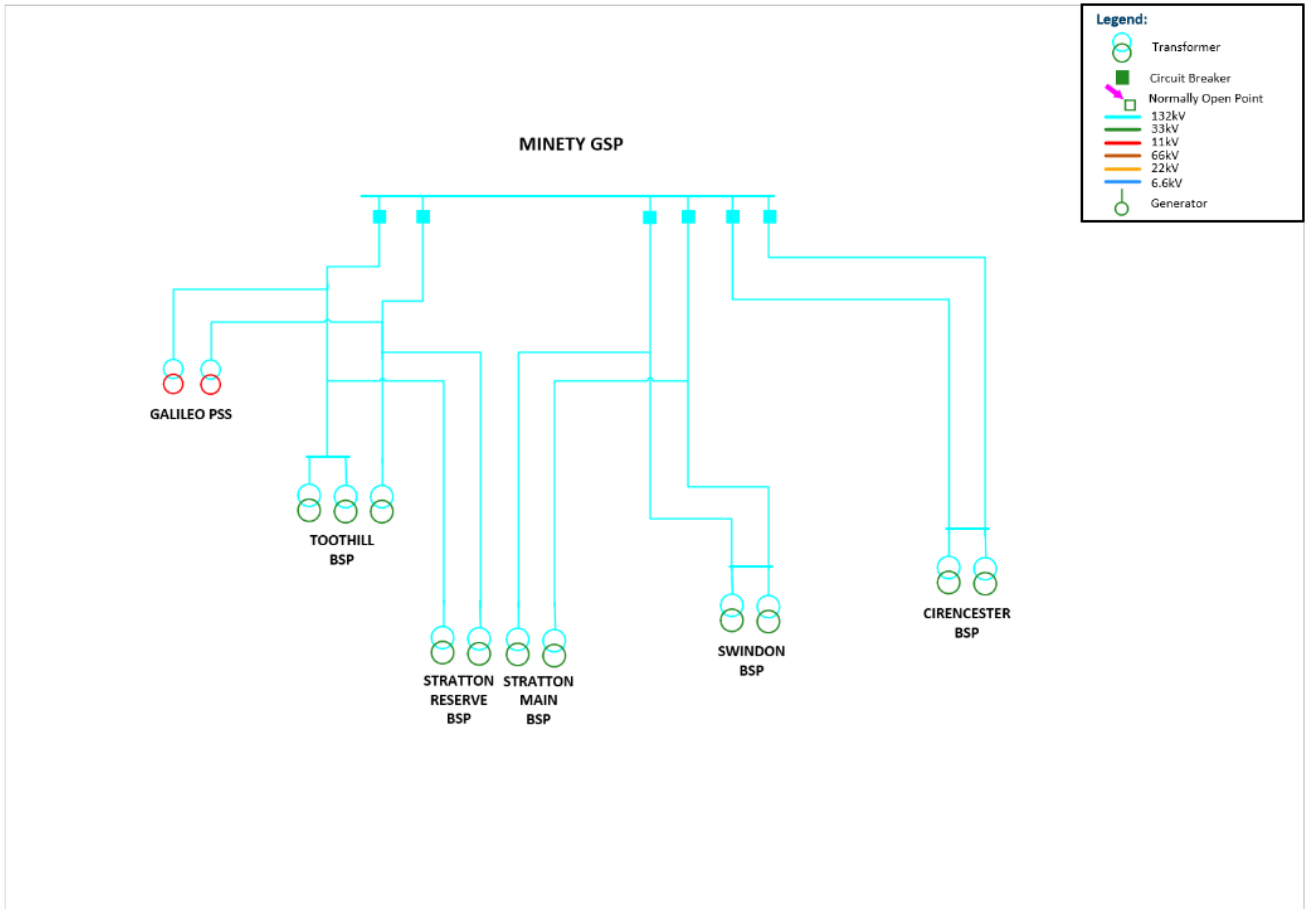

Figure 6 Existing network supplied by Minety GSP



5. FUTURE ELECTRICITY LOAD AT MINETY GSP

The following section details load growth across the technologies projected in the Distribution Future Energy Scenarios. There are important notes on the values presented here:

- These projections relate to the GSP supply area highlighted in Figure 1 and are not directly aligned to a particular local authority.
- Where MW values are presented in this section, they represent total installed capacity. When conducting network studies these values are appropriately diversified to represent the coincident maximum demand of the entire system rather than the total sum of all demands.
- For projections specific to individual primary substations or local authorities, please refer to our online dashboard.²⁷

5.1. Generation and Storage

5.1.1. Distributed Energy Resources (DER)

Minety GSP contains a high level of distributed generation which means reverse power flows from the Distribution to the Transmission network are common. These reverse flows can lead to various grid disturbances, such as voltage fluctuations, increased fault levels, and protection coordination challenges. As such, they must be carefully considered in the design, operation, and asset management strategies of the network. The region comprising Minety GSP hosts strong land availability, with proximity to both generation assets and industrial demand centres in the South of England. Minety is home to the 150MW battery storage project in Wiltshire, which is one of the biggest storage facilities in Europe²⁸. In addition to its technical capacity, the project represents a milestone in the commercialisation of battery energy storage in the UK, demonstrating how large-scale battery systems can be deployed rapidly to meet decarbonisation and reliability goals.

Swindon region is home to a number of solar PV farms; the region has high solar irradiance particularly when compared to midlands and the north. Cotswold has an increasing number of renewable energy assets being installed, there is significant uptake in the region and since 2025 there has been an average of 110 per month²⁹. The Vale of White Horse district plays an active role in Oxfordshire's growing solar energy landscape, with several significant photovoltaic (PV) installations either operational or in development. However, unlike neighbouring areas such as Swindon or the Minety GSP site near Swindon, the Vale currently does not host any major grid-scale battery energy storage systems, though future developments may address this gap as the regional energy system evolves. Ongoing grid connection reform, led by Ofgem and NESO, is aiming to accelerate access to the electricity network for DER and large energy users, helping to address current installation backlogs and unlock capacity for the region³⁰.

²⁷ [SSEN DFES Technology Projections - Microsoft Power BI](#)

²⁸ [Minety Battery Storage | Eclipse Power Networks](#)

²⁹ [Renewables revolution: Cotswold region sees spike in installations - MCS](#)

³⁰ [Connections Reform | National Energy System Operator](#)
Minety Grid Supply Point: Strategic Development Plan



DFES Scenario	Generation capacity				Electricity storage capacity			
	Baseline	2030	2040	2050	Baseline	2030	2040	2050
Holistic Transition	415MW	988MW	1401MW	1554MW	171MW	474MW	532MW	562MW
Electric Engagement		842MW	1078MW	1246MW		467MW	512MW	537MW
Hydrogen Evolution		703MW	953MW	1101MW		359MW	492MW	510MW
Counterfactual		657MW	754MW	822MW		254MW	370MW	382MW

Table 2 Projected cumulative distribution connected generation capacity and electricity storage capacity across Minety GSP (MW). Source: SSEN DFES 2024

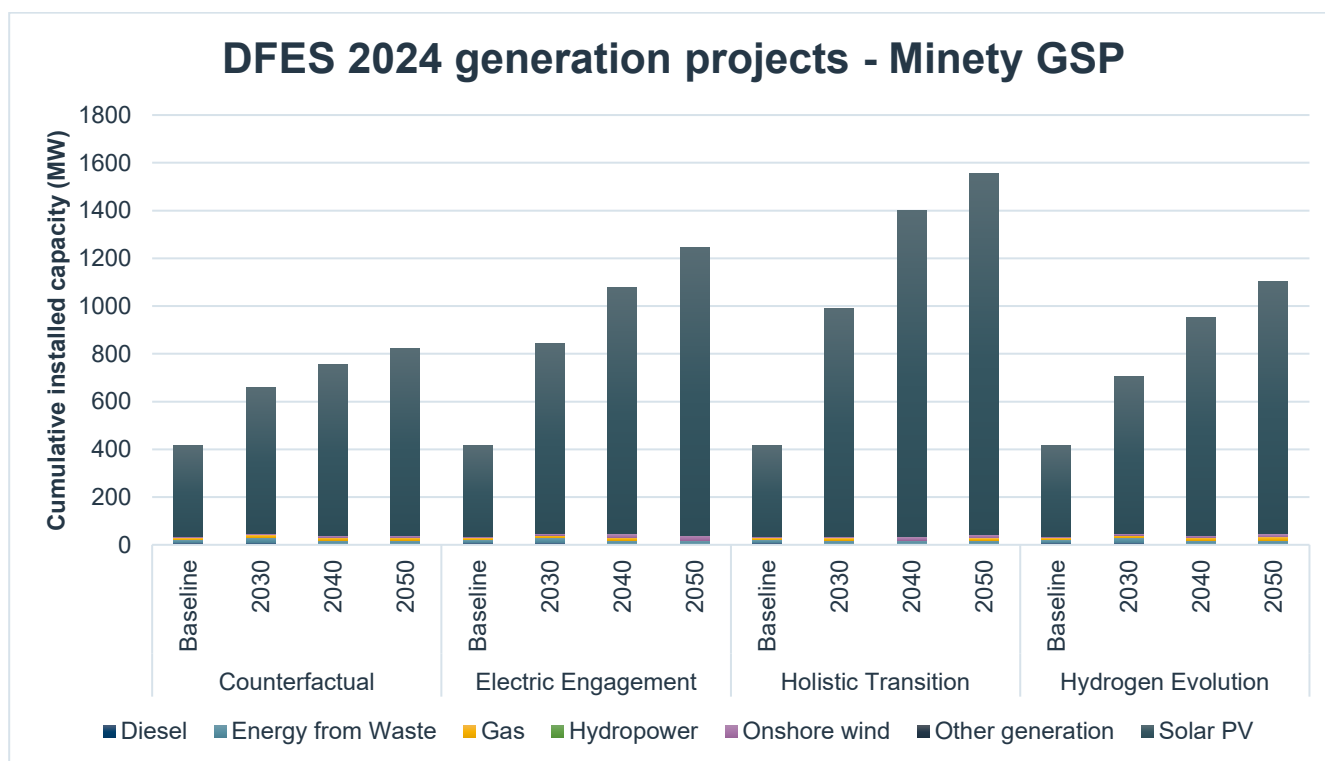

Figure 7 Projected cumulative distributed generation capacity Minety GSP (MW). Source: SSEN DFES 2024

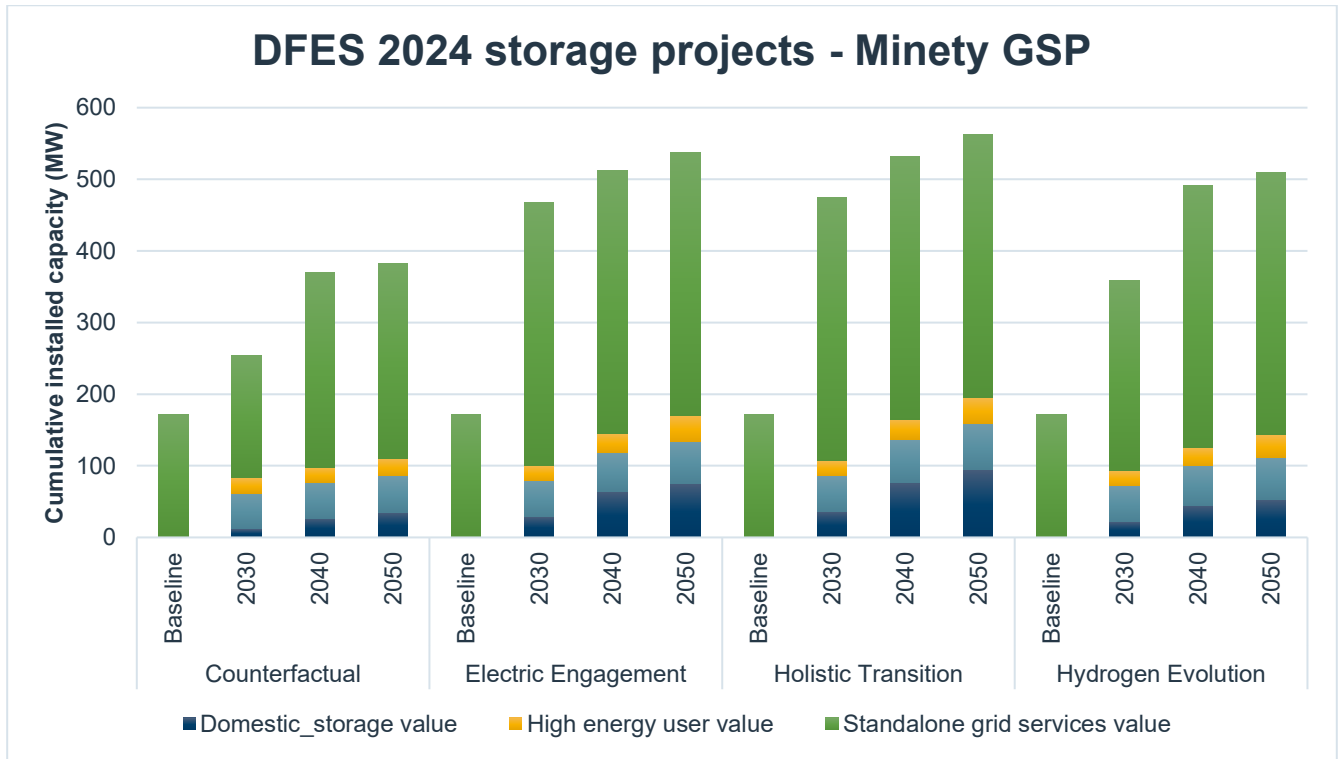

Figure 8 Projected cumulative distributed storage capacity Minety GSP (MW). Source: SSEN DFES 2024



5.2. Transport Electrification

DFES Scenario	Chargers - Domestic (number of units)				Chargers – Non-domestic (MW)			
	Baseline	2030	2040	2050	Baseline	2030	2040	2050
Holistic Transition	10,908	38,083	109,186	114,335	5MW	34MW	157MW	176MW
Electric Engagement		60,185	108,721	113,184		57MW	175MW	181MW
Hydrogen Evolution		37,871	108,240	112,704		19MW	101MW	116MW
Counterfactual		31,367	103,531	111,784		40MW	189MW	212MW

Table 3 Projected cumulative number of domestic EV chargers (off-street) and non-domestic and domestic (on-street) EV charge point capacity across Minety GSP. *Source: SSEN DFES 2024*

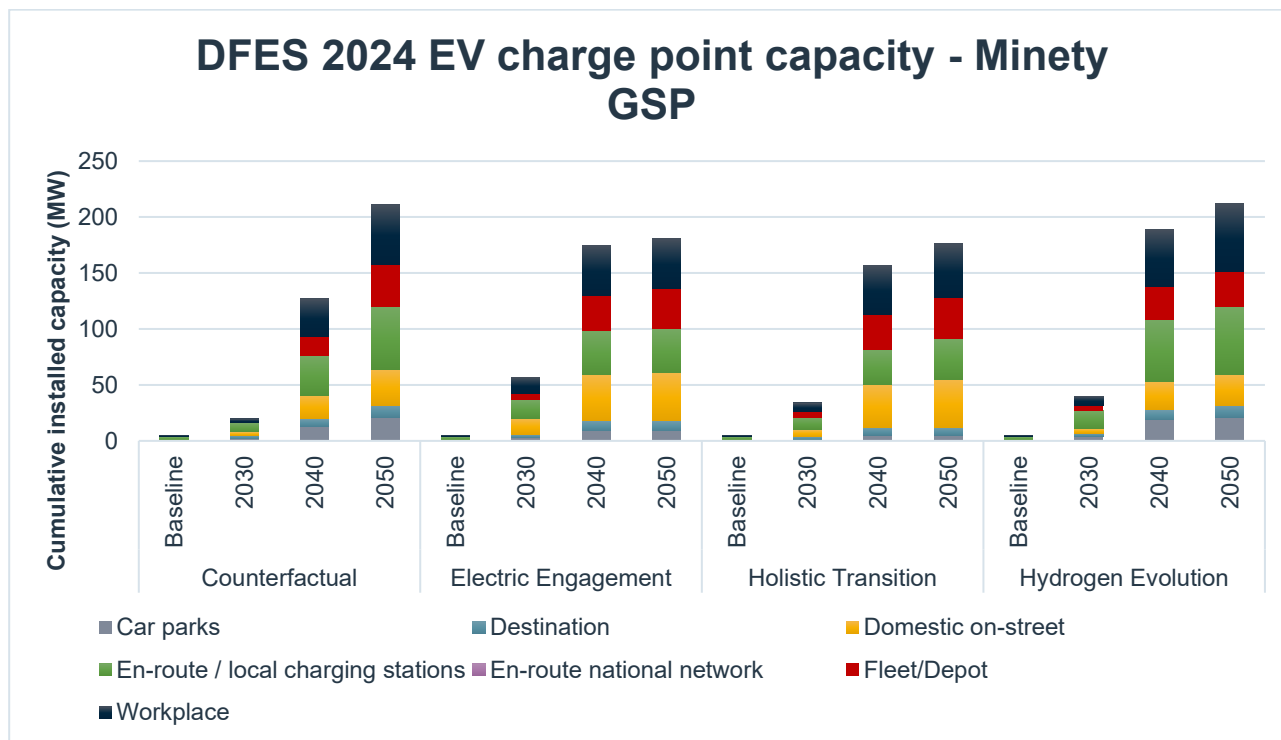

Figure 9 Projected EV charge point capacity across Minety GSP. *Source: SSEN DFES 2024*



5.3. Electrification of heat

DFES Scenario	Non-domestic heat pumps (m ² of floorspace)				Domestic heat pumps (number of units)			
	Baseline	2030	2040	2050	Baseline	2030	2040	2050
Holistic Transition	759,241m ²	2,266,746m ²	4,938,262m ²	6,098,767m ²	20,189	38,875	102,355	127,621
Electric Engagement		1,817,957m ²	4,971,305m ²	6,192,839m ²		39,479	114,572	176,837
Hydrogen Evolution		1,945,287m ²	4,019,393m ²	4,817,888m ²		39,268	106,124	171,816
Counterfactual		1,317,139m ²	2,799,892m ²	3,369,258m ²		32,206	77,978	203,275

Table 4 Projected non-domestic heat pumps and resistive electric heating floorspace and number of domestic heat pumps across Minety GSP. Source: SSEN DFES 2024

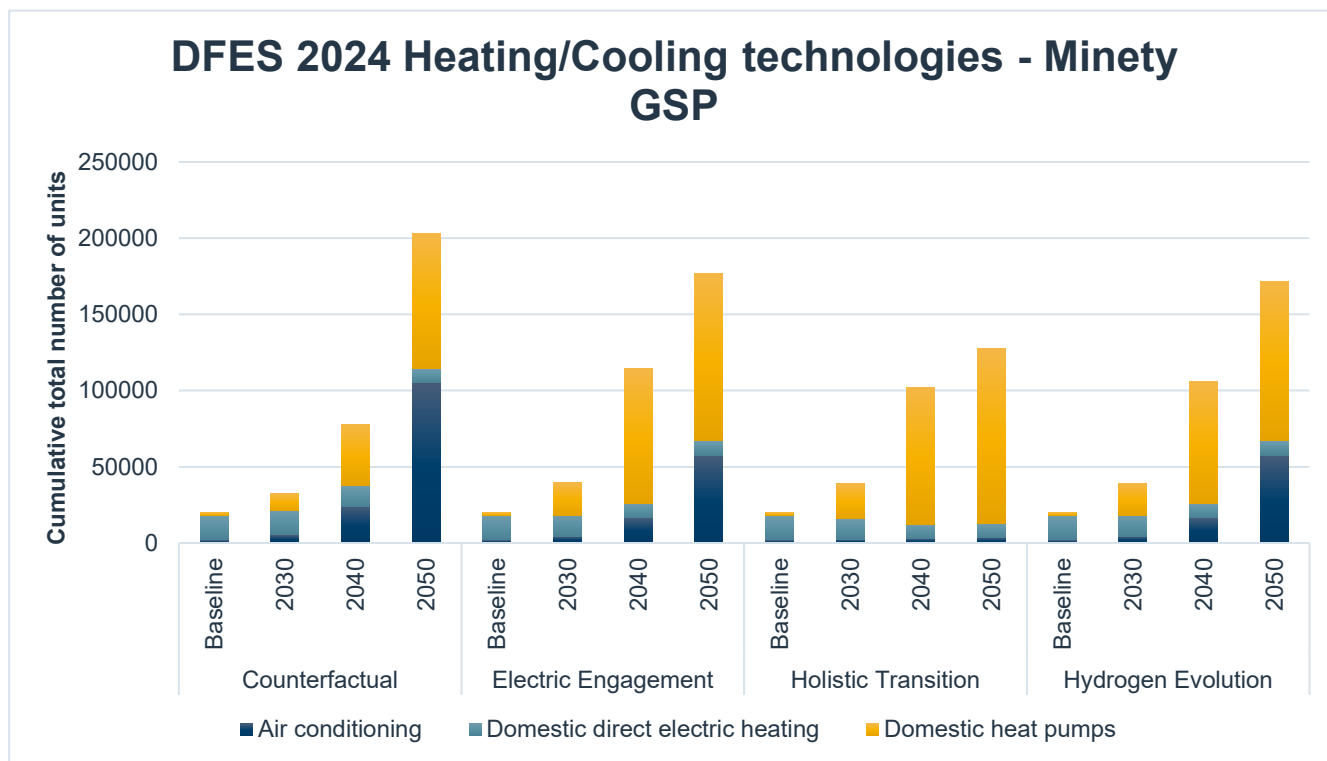

Figure 10 Projected number of heating/cooling technologies across Minety GSP. Source: SSEN DFES 2024

5.4. New building developments



Through engagement with local authorities, we have developed an understanding of new development across our license areas. This has allowed us to gauge an insight into future electricity demand for new developments ahead of a formal connection application. Below we investigate the non-domestic new developments across the study area for this SDP.

DFES Scenario	New domestic development (number of homes)			New non-domestic development (m ²)		
	2030	2040	2050	2030	2040	2050
Holistic Transition	8,985	24,861	34,896	513,238	1,086,052	1,100,052
Electric Engagement	8,266	23,778	32,339	287,215	1,086,052	1,100,052
Hydrogen Evolution	8,296	23,799	32,355	279,611	1,086,052	1,100,052
Counterfactual	7,143	22,258	29,679	118,077	1,086,052	1,100,052

Table 5 Projected new domestic and non-domestic development across Minety GSP. Source: SSEN DFES 2024

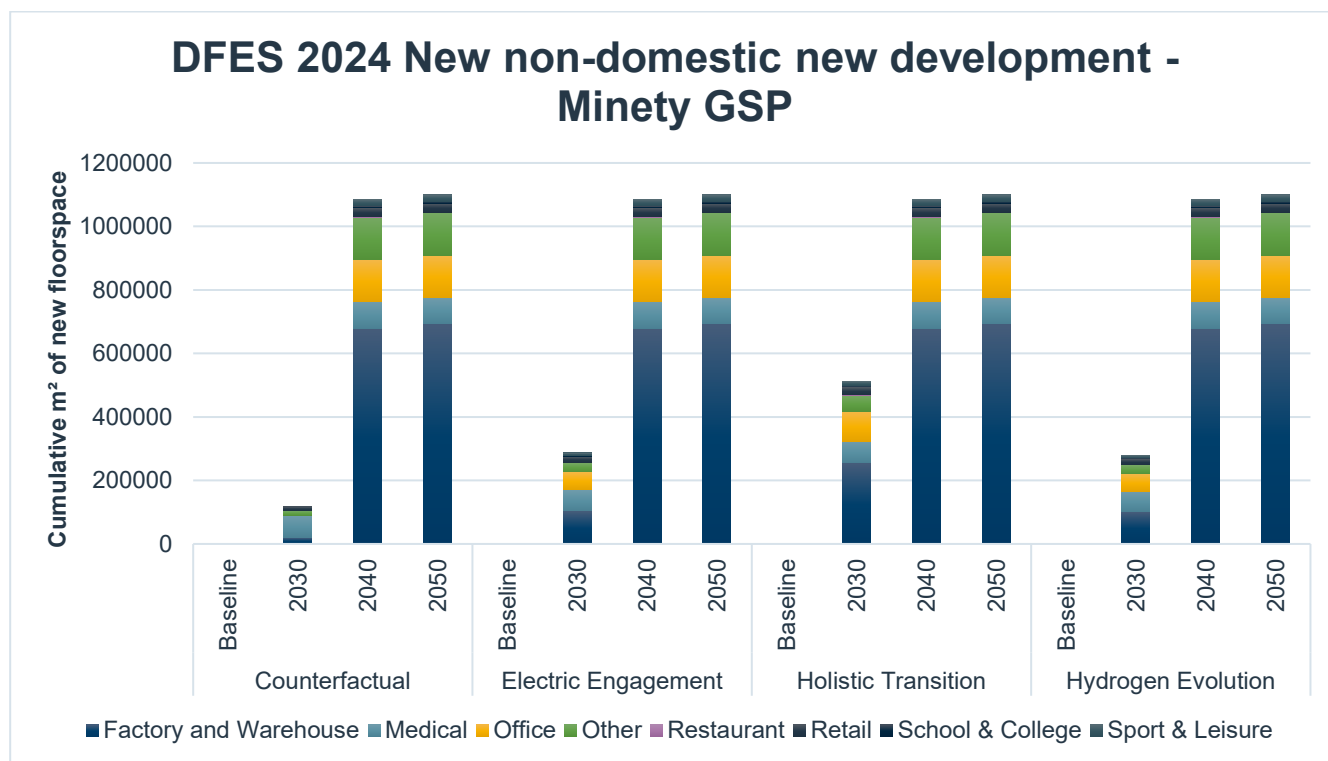

Figure 11 non-domestic new development under Minety GSP. Source: SSEN DFES 2024



5.5. Commercial and industrial electrification

5.5.1. Agricultural Decarbonisation

Decarbonisation of the agricultural sector is an important consideration in this geographic area. SSEN leads the innovation project 'Future Agricultural Resilience Mapping' ([FARM](#)) which aims to understand the future energy requirements and means of decarbonising the domestic farming industry. This sector is currently still largely dependent on fossil fuels, and the project will support its investigations into the impact of food production on the electricity distribution system, to work out where reinforcement is needed. A data-driven tool to inform network planning will be devised and through this work, FARM will address the gap between the energy demands for food production and future network planning.



6. WORK IN PROGRESS

Network interventions can be caused by a variety of different drivers. Examples of common drivers are load-related growth, specific customer connections, and asset health. Across Minety GSP these drivers have already triggered network interventions that have now progressed to detailed design and delivery. For this report, these works are assumed to be complete, with any resulting increase in capacity considered to be released. A summary of existing works is tabulated below.

ID	Substation	Description	Driver	Forecast completion	Resolves future strategic needs to 2050?
132kV Works.					
1	Mintey GSP.	Reinforcement of the 132kV busbar at Mintey GSP.	Customer Connection.	2031	
2	Mintey GSP to Cirencester BSP 132kV circuit sections.	Reinforcement of a 0.37km dual cable section between Mintey GSP and Cirencester BSP to match the 171MVA rating of the rest of the circuits.	Customer Connection.	2028	
3	Mintey GSP to Swindon BSP and Stratton Main BSP 132kV circuit sections.	Reinforcement of a 50m dual cable section between Mintey GSP and Swindon/Stratton Main BSP to match the 262MVA rating of the rest of the circuits.	Customer Connection.	2037	
4	Toothill BSP.	Replacement of the two lower rated 45MVA transformers to unbanked 90MVA units at Toothill BSP, along with a new 132kV GIS double busbar.	Customer Connection.	2027	
5	Stratton Reserve BSP.	Reinforcement of the existing 2 x 60MVA transformers to 2 x 90MVA units.	Asset Replacement	2027	
6	Swindon BSP.	Installation of a new 132kV AIS double busbar.	Customer Connection.	2028	
7	Mintey GSP to Toothill BSP and Galileo Primary	Reinforcement of a 50m single cable section between Mintey GSP and Galileo/Toothill BSP to match the	Customer Connection.	2037	



	132kV circuit sections.	264MVA rating of the rest of the circuits.			
Cirencester BSP					
8	Cirencester BSP to Minety Village PSS 33kV circuits.	Additional 33kV 9.65km dual circuits installed between Cirencester BSP and Minety Village PSS.	DNOA Process.	2031	
9	Cirencester BSP to Cricklade PSS 33kV circuits.	Additional 33kV 12.7km circuit installed between Cirencester BSP and Cricklade PSS.	DNOA Process.	2031	
10	Cirencester Town PSS.	Reinforcement of the existing 2 x 21MVA transformers to 2 x 20/40MVA units, and the reinforcement of the 33kV circuits from Cirencester BSP to Cirencester Town PSS.	Customer Connection.	2029	
Stratton Reserve BSP					
11	Faringdon PSS.	Reinforcement of the existing transformers at Faringdon PSS from 2 x 14.3MVA units to 2 x 20/40MVA units and the extension of the 33kV busbar along with new circuit breaker. Installation of an additional 33kV circuit from Stratton Reserve BSP to Faringdon PSS.	DNOA Process.	2029	
12	Stanton Fitzwarren PSS to Faringdon PSS 33kV circuits.	Reconducting of 8.62km of 33kV overhead circuits between Stanton Fitzwarren PSS and Black Bourton PSS to match the thermal rating of the rest of the circuit.	Customer Connection.	2025	
13	Stratton Reserve BSP to Stanton Fitzwarren PSS 33kV circuits.	Installation of a new 3.6km 33kV circuit between Stratton Reserve BSP and Stanton Fitzwarren PSS.	Customer Connection.	2027	



Stratton Main BSP					
14	Green Road Switching Substation.	Green Road switching substation circuit breaker upgrade.	Customer Connection.	2028	
15	Pressed Steel Swindon PSS.	Reinforcement of the 4 existing transformers at Pressed Steel Swindon PSS to 4 x 15/30MVA units and 33kV board replacement.	Asset Replacement	2028	
Toothill BSP					
16	Wroughton PSS.	New 33kV double busbar at Wroughton PSS and the installation of 4.9km of dual 33kV circuits rated at 35MVA between Toothill BSP and Wroughton PSS.	Customer Connection.	2027	

Table 6 Works already triggered through customer connections, DNOA process and asset replacement.

Where the above works are marked as not providing sufficient capacity for 2050 peak demands, it is important to note that this relates to the individual primary substation's firm capacity. When considering the further works identified in this report, the holistic plans aim to provide capacity across the GSP for 2050 based on current projections.

Alongside these asset solutions being deployed, flexibility solutions are also being used to release additional capacity.



6.1. Network Schematic (following completion of above works)

The network schematic below in Figure 12 shows the 132kV network with changes highlighted and referenced to the table above. Additional schematics for changes to the 33kV network supplied by Minety GSP can be found in Appendix B.

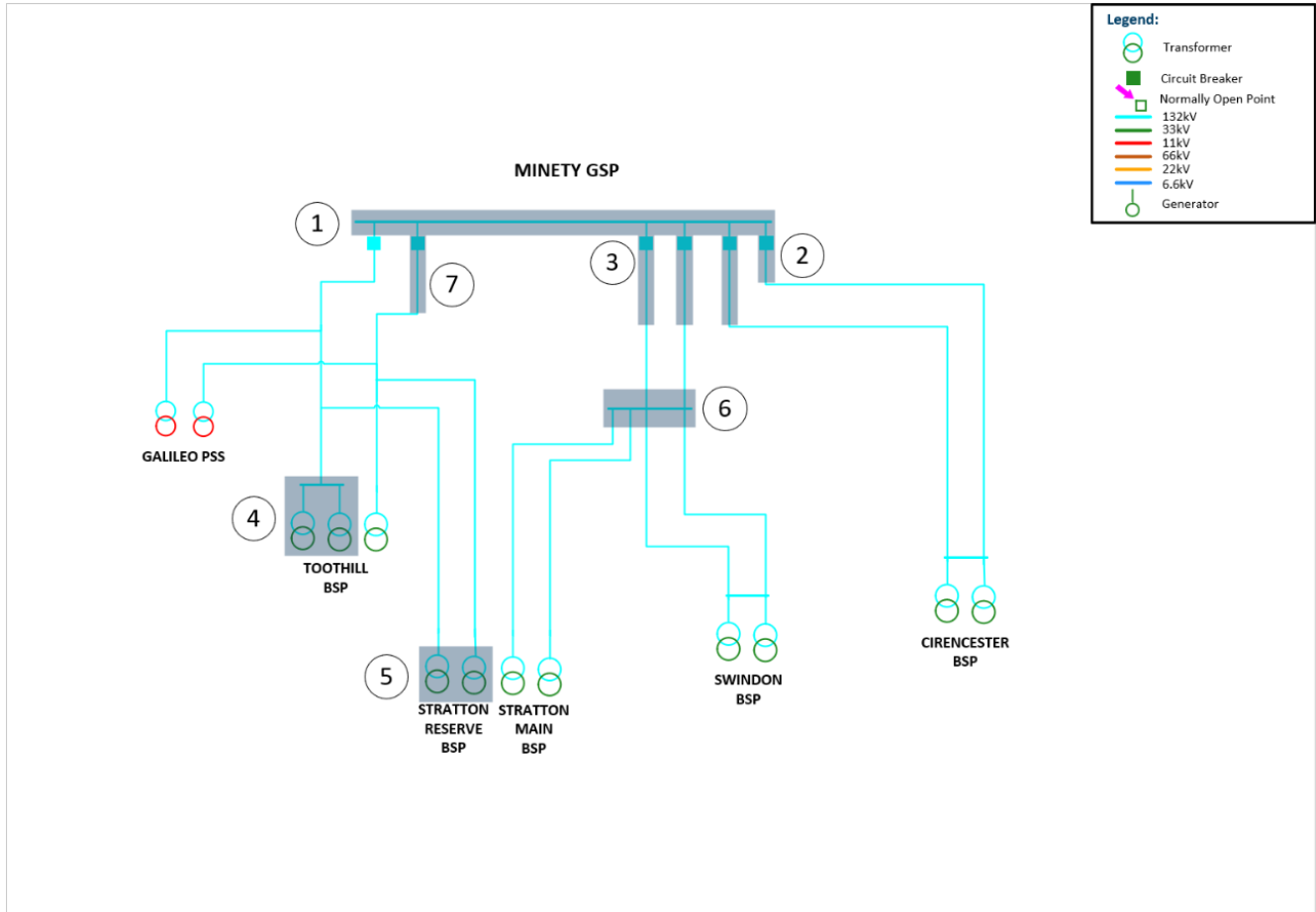

Figure 12 Minety Network schematic following completion of triggered works.



7. SPATIAL PLANS OF FUTURE NEEDS

7.1. Extra High Voltage / High Voltage spatial plans

The EHV/HV spatial plan shown below in Figure 13 shows the projected headroom or capacity shortfall due to demand increases at primary substations across the Minety SDP study area. Darker shades indicate that there is a projected capacity shortfall whereas lighter blue shades indicate that there is headroom capacity based on current projections. EHV/HV spatial plans for the other DFES scenarios are presented in Appendix C.

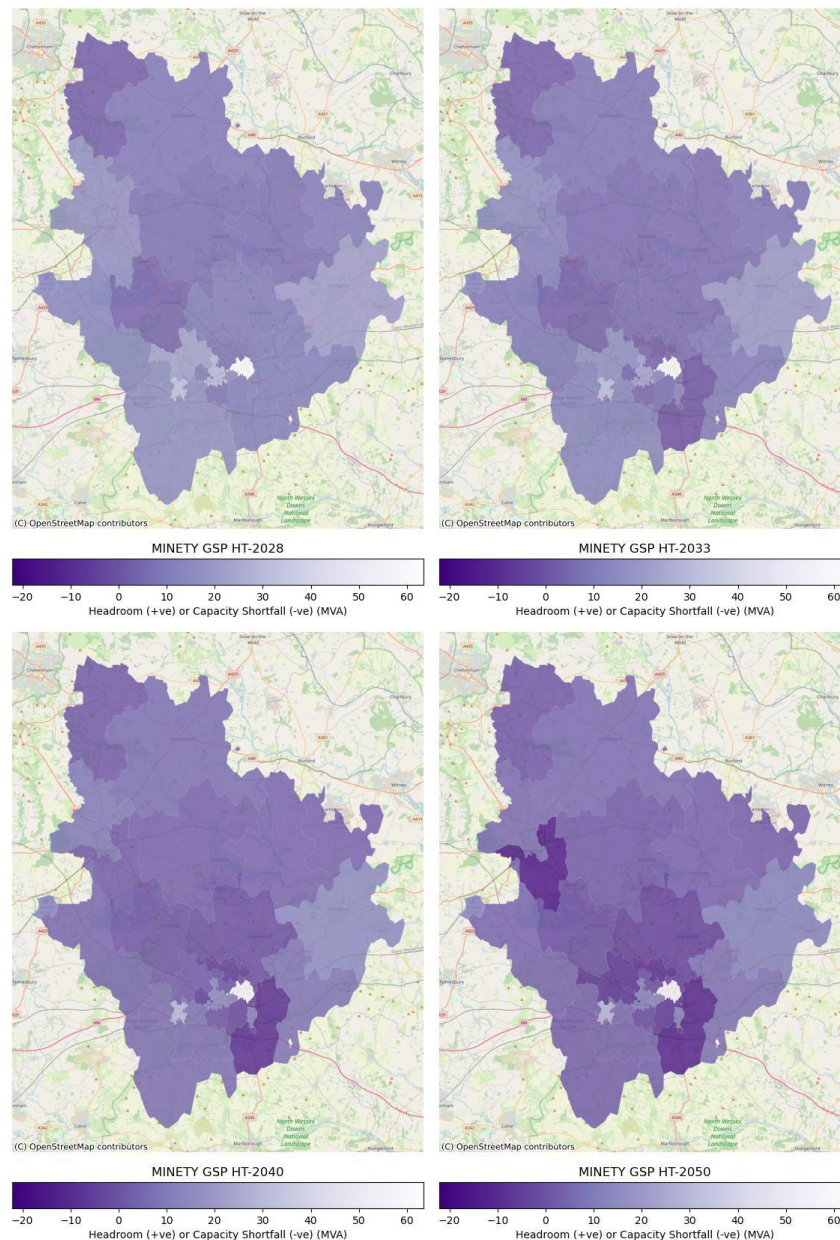

Figure 13 Minety GSP - EHV/HV Spatial Plans – Holistic Transition



7.2. HV/LV spatial plans

The HV/LV spatial plans shown below in Figure 14 show the point locations of secondary transformers supplied by Minety GSP. The data below is drawn from the DFES 2024. The points are coloured based on the projected percentage loading with red meaning higher percentage loading and green being lower percentage loading. The HV/LV spatial plans for the other DFES 2024 scenarios are available in Appendix D.

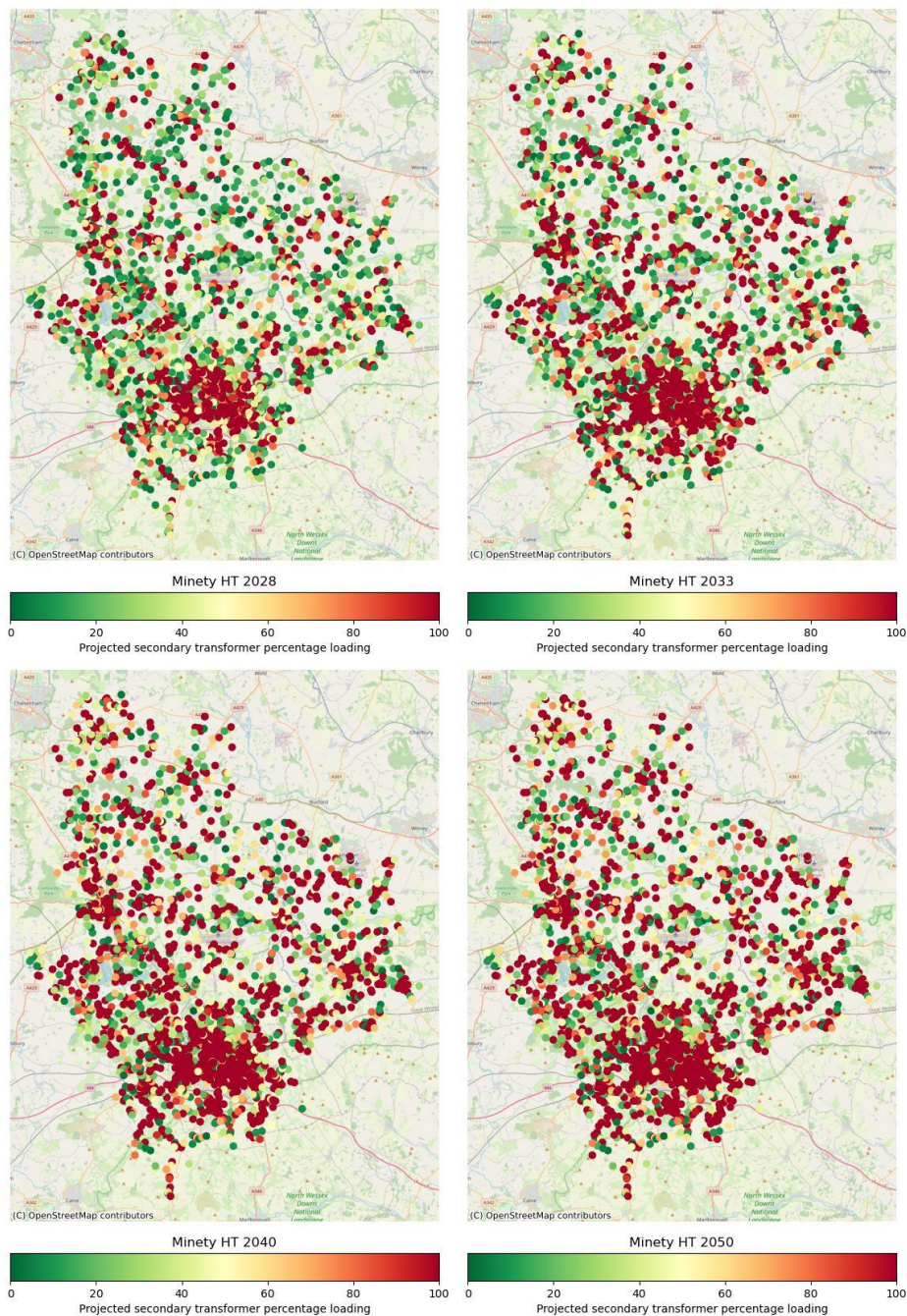

Figure 14 Minety GSP - HV/LV Spatial Plans - Holistic Transition



8. SPECIFIC SYSTEM NEEDS AND OPTIONS TO RESOLVE

8.1.1. Overall dependencies, risks, and mitigations

There are several overarching risks to the delivery of our strategic plan. Below we list these alongside proposed mitigating actions. We will work with stakeholders to develop these mitigating actions further.

Highlight the potential dependencies/risks and what we have done here or plan to do to mitigate these risks.

Dependency: Delivery of the reinforcement work highlighted in the works in progress section (section 6) will be required to enable both capacity in the near-term but may also enable the proposed future options in this system needs section.

Risks: Delays or changes to triggered works fail to release capacity in the near-term and/or do not provide flexibility of future investment.

Mitigation: Current reinforcement projects are included in this strategic development plan and dependencies are identified as part of the DNOA process and form part of the handover of work to delivery teams for consideration. Proposed work should also ensure that it is enabling future network development such as considering space constraints at the site.

Dependency: Growth of generation in the area may begin to cause reverse power flow on the network. It should be ensured that the assets currently on the network are able to handle the projected levels of reverse power flow and increased fault level.

Risks: Further reinforcement than identified here is required to enable connection of generation. Increasing fault levels can lead to damaged distribution network assets.

Mitigation: We should further assess the near-term generation requirements to ensure that we are in a position to facilitate the Clean Power 2030 targets set by DESNZ. Consideration of future fault level to prevent the risk of damaged assets should be considered when designing future schemes.

Dependency: Future works may require expansion of the Minety 132kV substation.

Risks: Due to spatial constraints on the existing GSP circuit board, further site expansion is currently limited.

Mitigation: Assess the implications of the space constraints at the Minety GSP site on future works and engage with NGET on long-term site planning.

8.2. Future EHV System Needs ahead of 2035

The following table details the near-term to medium-term distribution network system needs that have been identified through power system analysis. While asset solutions are described in the table below it is important to note that the use of flexibility will be evaluated for all schemes to ensure the best possible solution is progressed to meet the required timescales



For the projects shown in Table 7 we recommend that these are progressed through the DNOA process so that there is sufficient time for solutions to be designed and delivered.

ID	Location of proposed intervention	HT Year	EE Year	HE Year	CF Year	Network State	Comments and potential options to resolve the system need
132kV Network							
1	Minety GSP to Swindon BSP first section. Circuit 1 or 2.	2025 - 2030	2025 - 2030	2025 - 2030	2025 - 2030	N-1, Loss of the circuit feeding Minety GSP	<p>A security of supply issue occurs during the same period for all four scenarios under loss of both segments feeding Minety GSP to Swindon BSP which should be considered when assessing the options below. Segment 1 and segment 2 line segments are both connected, any reinforcements should be considered in parallel.</p> <ul style="list-style-type: none"> Add a third 132kV circuit from Swindon GSP. Replace and uprate both existing circuits from Minety GSP to Swindon BSP. Add additional 33kV interconnection points between Swindon BSP and/or nearby BSPs in Bramley-Thatcham GSP or Melksham GSP depending on capacity. Use of flexibility to resolve constraints.
	Minety GSP to Swindon BSP second section. Circuit 1 or 2	2025 - 2030	2025 - 2030	2025 - 2030	2025 - 2030	N-1, Loss of the circuit feeding Minety GSP	
2	Swindon BSP transformers	2025 - 2030	2025 - 2030	2025 - 2030	2025 - 2030	N-1, loss of one of the transformers	<p>Both transformers are predicted to overload in N-1 conditions.</p> <ul style="list-style-type: none"> Add a third transformer at Swindon BSP.
33kV Network							
3	33kV circuits from Wroughton PSS to Common PV	2025 - 2030	2025 - 2030	2025 - 2030	2025 - 2030	N-1, loss of one of the circuits	<p>The 33kV circuits between Wroughton PSS and the transformers are expected to be overloaded in N-1 conditions. Potential options to resolve this constraint are:</p> <ul style="list-style-type: none"> Reinforce the existing 33kV circuits to Wroughton PSS, either by adding additional assets or uprating the existing ones. Install an additional line from Toothill BSP direct to the Wroughton PSS to Common PV route, given the proximity between the assets, this option would provide good long term assurance. Use of flexibility to alleviate constraints.
	Wroughton PSS transformers	2025 - 2030	2025 - 2030	2025 - 2030	2025 - 2030	N-1. Loss of one of the transformers	
4	Chisledon PSS transformers	2025 - 2030	2025 - 2030	2025 - 2030	2025 - 2030	N-1. Loss of one of the transformers	<p>The transformers at Chisledon PSS are both projected to be overloaded in N-1 conditions, as is the 33kV circuit between Dorcan and Chisledon primaries. Due to their proximity, it's proposed</p>



ID	Location of proposed intervention	HT Year	EE Year	HE Year	CF Year	Network State	Comments and potential options to resolve the system need
	33kV line segment between Toothill BSP and Chisledon PSS from Cirencester BSP	2025 - 2030	2025 - 2030	2025 - 2030	2025 - 2030	N-1, loss of the lines	<p>these works are completed together. Potential options to resolve this constraint are to;</p> <ul style="list-style-type: none"> Reinforce the existing transformers at Chisledon PSS and the circuits between them, either by adding additional assets or uprating the existing ones. Build new 33kV circuits feeding Chisledon PSS directly from Toothill BSP and reinforce existing transformers. Move Chisledon PSS to be fed from Melksham GSP and reinforce existing transformers. Use of flexibility.
5	Minety village and Kemble PSS line segment	2025 - 2030	2025 - 2030	2025 - 2030	2025 - 2030	N-1. Loss of one of the transformers	<p>Potential options to resolve this constraint are to;</p> <ul style="list-style-type: none"> Replace and uprate the existing transformers and circuits. Add a third transformer and a third circuit from Minety GSP. Use of flexibility.
6	Cricklade PSS transformers	2025 - 2030	2025 - 2030	2025 - 2030	2025 - 2030	N-1. Loss of one of the transformers	<p>Cricklade PSS transformers are projected to overload under N-1 in 2025-2030. Potential options to resolve this constraint are:</p> <ul style="list-style-type: none"> Replace and uprate the transformers Add a third transformer Use of flexibility.
7	Dorcan South PSS transformers	2025 - 2030	2025 - 2030	2025 - 2030	2025 - 2030	N-1. Loss of one of the transformers	<p>The two transformers at Dorcan South PSS have two different ratings, 18.75MVA and 12MVA. The transformer of a lower rating is projected to overload in 2025. Potential options to resolve this constraint are to;</p> <ul style="list-style-type: none"> Upgrade and uprate the existing transformers Add a third transformer
8	Park North PSS Transformers	2025 - 2030	2025 - 2030	2025 - 2030	2025 - 2030	N-1. Loss of one of the transformers	<p>Both Park North transformers are projected to be overloaded in N-1 conditions, in all scenarios out to 2030. Option to resolve include:</p> <ul style="list-style-type: none"> Replace and uprate the existing transformers and circuits. Add a third transformer and a third circuit from Minety GSP. Use of flexibility to resolve constraint.
9	33kV circuit between Pressed Steel Swindon and Drakes Way PSS	2025 - 2030	2025 - 2030	2025 - 2030	2025 - 2030	N-1, Loss of the 33kV circuits feeding Drakes Way	<p>The circuit between Pressed Steel Swindon and Drake Way PSS is projected to be overloaded under N-1 conditions before 2030. While the existing NOP at Pressed Steel Swindon offers short-term load relief, a long-term solution is</p>



ID	Location of proposed intervention	HT Year	EE Year	HE Year	CF Year	Network State	Comments and potential options to resolve the system need
							required. A potential option to resolve this is an additional circuit to support Drakes Way PSS with a direct 33kV circuit from Stratton BSP Flexibility should also be considered to resolve constraint.
10	Wootton Bassett PSS Transformers	2025 - 2030	2025 - 2030	2025 - 2030	2025 - 2030	N-1, Loss of one of the transformers	Wootton Bassett consists of two transformers projected to overload in N-1 conditions, the ratings of the transformers are both 12MVA. This region is not closely connected to other primaries, so load shifting was discounted due to practical considerations. Option to resolve include: <ul style="list-style-type: none"> Replace and uprate the existing transformers. Add a third transformer and a third circuit from Swindon BSP Use of flexibility to alleviate constraint.
11	Manchester Rd PSS Transformers	2025 - 2030	2025 - 2030	2025 - 2030	2025 - 2030	N-1, Loss of one of the transformers	The two 33kV circuits between Manchester Road and the transformers at Manchester Road PSS are expected to be overloaded in N-1 conditions. Potential options to resolve this constraint are: <ul style="list-style-type: none"> Reinforce the existing circuits and transformers at Manchester Road PSS, either by adding additional assets or uprating the existing ones. As there is only interconnection to other customer owned solar assets, it is not feasible to shift load. A new primary could be built to alleviate constraints. Use of flexibility.
	Swindon BSP to Manchester Road PSS Line Segment 1	2025 - 2030	2025 - 2030	2025 - 2030	2025 - 2030	N-1, Loss of one of the circuits	
	Swindon BSP to Manchester Road PSS Line segment 2	2025 - 2030	2025 - 2030	2025 - 2030	2025 - 2030	N-1, Loss of one of the circuits	
12	Stanton Fitzwarren PSS transformers	2025 - 2030	2025 - 2030	2025 - 2030	2025 - 2030	N-1, Loss of one of the transformers	Stanton Fitzwarren is fed directly from Stratton BSP with a distance of less than 5km for each of the three lines, Potential options to resolve constraint under N-1: <ul style="list-style-type: none"> Replace and uprate the existing transformers and circuits Add a third transformer and a third circuit from Stratton BSP Use of flexibility services..
13	Shipton Oliffe PSS Transformers	2025 - 2030	2025 - 2030	2025 - 2030	2025 - 2030	N-1, Loss of one of the transformers	<ul style="list-style-type: none"> Replace and uprate the existing transformers and circuits. Add a third transformer and a third circuit from Cirencester BSP, but considering the distance a load shift from Shipton Oliffe PSS to Northleach PSS or Whiteway PSS could be a suitable short-term solution. Use of flexibility to resolve constraint.



ID	Location of proposed intervention	HT Year	EE Year	HE Year	CF Year	Network State	Comments and potential options to resolve the system need
14	Northleach PSS transformers	2025 - 2030	2025 - 2030	2025 - 2030	2025 - 2030	N-1, Loss of one of the transformers	<p>Northleach and Shipton Oliffe PSS are within close proximity, so any works reinforcements could be considered at the same time to ensure that there is sufficient capacity to load shift. Other potential options to resolve include:</p> <ul style="list-style-type: none"> • Replace and uprate the existing transformers • Add a third transformer and a third circuit from Cirencester BSP • Use of flexibility to alleviate constraint.
15	Black Bourton PSS transformers	No Issue	2025 - 2030	2025 - 2030	No Issue	N-1, Loss of one of the transformers	<p>This transformer is served directly from Stratton BSP, the other PSS transformers in the area Stanton Fitzwarren is also projected to be overloaded in the same timeframe, so it is not feasible to transfer load. Therefore, the potential options to resolve are:</p> <p>Reinforce the existing transformers at Silkstead, either by</p> <ul style="list-style-type: none"> - adding additional assets or uprating the existing ones - construct a new primary in the area - use of flexibility to resolve constraint.
16	Wroughton PSS transformers	2025 - 2030	2025 - 2030	2025 - 2030	2025 - 2030	N-1, Loss of one of the transformers	<p>Wroughton is primary with two transformers projected to overload in the same timescale for all four scenarios, there is an interconnection between Chisledon PSS and Dorcan South PSS but as this are also projected to overload it may not be suitable to shift load until the timelines for reinforcements are established.</p> <ul style="list-style-type: none"> • Reinforce the existing transformers, either by adding additional assets or uprating the existing ones. • Use of flexibility to resolve constraint.

Table 7 Summary of system needs identified in this strategy through to 2035 along with indicative solutions.



8.3. Future EHV System Needs to 2050

ID	Location of proposed intervention	HT Year	EE Year	HE Year	CF Year	Network State	Comments and potential options to resolve the system need
132kV Network							
17	Stratton Main BSP transformers	2038 - 2045	2038 - 2045	2038 - 2045	2038 - 2045	N-1, Loss of one of the transformers at Stratton Main BSP	<p>Constraints begin to appear on the BSP transformers at Stratton Main BSP in the same time frame across all four scenarios.</p> <p>Potential options to resolve this constraint are:</p> <p>Add a fourth BSP transformer at Stratton Main BSP.</p> <ul style="list-style-type: none"> Transfer load Stratton Main BSP to Toothill BSP. Replace and uprate both transformers, or add a third transformer at Stratton Main BSP BSP. Transfer load from Stratton Main BSP to Stratton Reserve BSP Transfer load to Melksham GSP and/or Nursling GSP.
18	Minety GSP to Swindon BSP circuit 2 third section. Section before Faxlands Manor battery.	2038 - 2045	2038 - 2045	2038 - 2045	2038 - 2045	N-1, Loss of one of the circuits feeding Swindon BSP.	<p>A security of supply issue occurs during the same period for all four scenarios under loss of both circuits feeding Swindon BSP which should be considered when assessing the options below.</p> <ul style="list-style-type: none"> Add a third 132kV circuit from Minety GSP. Replace and uprate both existing circuits from Minety GSP. Add additional 33kV interconnection points between Minety GSP and Swindon BSP and/or nearby BSPs in Nursling GSP or Melksham GSP.
19	Minety GSP to Swindon BSP circuit 2 section. From Faxlands Manor battery to Swindon BSP.	2038 - 2045	2038 - 2045	2038 - 2045	2038 - 2045	N-1, Loss of one of the circuits feeding Swindon BSP.	<p>The 33kV lines between Faxlands Manor battery to Swindon BSP become overloaded under N-1.</p> <p>Potential options to resolve this constraint are:</p> <ul style="list-style-type: none"> Reinforce the existing circuits between Faxlands Manor battery to Swindon BSP, either by adding additional assets or uprating the existing ones. Add a new circuit, either a new 33kV circuit potentially from Swindon BSP.
	Minety GSP to Swindon BSP rest of the section circuit segment.	2038 - 2045	2038 - 2045	2038 - 2045	2038 - 2045	N-1, Loss of one of the circuits feeding Swindon BSP.	
33kV Network							



ID	Location of proposed intervention	HT Year	EE Year	HE Year	CF Year	Network State	Comments and potential options to resolve the system need
20	Line between Galileo PSS and Minety main BSP	2038 - 2045	2038 - 2045	2038 - 2045	2038 - 2045	N-1, loss of one the lines from Galileo PSS to Minety Main BSP	Galileo PSS circuits line segment are expected to be overloaded in N-1 conditions. Potential options to resolve this constraint are: <ul style="list-style-type: none"> Reinforce the existing 33kV circuit sections, either by adding additional assets or uprating the existing ones. Due to the high number of customer owned assets in the area, and the long distance from other primaries, construction of a new primary may be the most efficient approach.
21	Minety main Toothill line to Lydiard Plain - 33kV (right segment)	2038 - 2040	2038 - 2045	2038 - 2045	2038 - 2045	N-1, Loss of one of the circuits	Overhead lines from Lydiard to Toothill BSP expected to be overloaded in N-1 conditions. Potential options to resolve this constraint are: <ul style="list-style-type: none"> Reinforce the overloaded circuit section 33kV circuit sections, either by adding additional assets or uprating the existing ones. Considering shifting load or adding a new primary in the area depending on the existing constraints
	Minety main Toothill line to Lydiard Plain - 33kV (left segment)	2038 - 2045	2038 - 2045	2038 - 2045	2038 - 2045	N-1, Loss of one of the circuits	
22	Line segment from Toothill to Swindon BSP (1)	2038 - 2045	2038 - 2045	2038 - 2045	2038 - 2045	N-1, Loss of one of the circuits	The circuit from Toothill BSP to Swindon BSP is projected to be overloaded under N-1 conditions. Potential options to resolve this constraint are: <ul style="list-style-type: none"> Uprate the line segments from Swindon BSP, Add a new 33kV circuit from Toothill BSP to Swindon BSP.
23	33kV circuits for Brindley Close battery	2038 - 2045	2038 - 2045	2038 - 2045	2038 - 2045	N-1, Loss of one of the circuits	The circuits in Brindley Close are projected to be overloaded during N-1 conditions. This constraint could be resolved by: <ul style="list-style-type: none"> Uprating the circuit from Swindon BSP to Brindley Close Battery. Alternatively, a 33kV circuit could be added or additional interconnection points between Manchester Road PSS and Brindley Close Battery
24	Lechlade PSS transformers	2038 - 2045	2038 - 2045	2038 - 2045	No Issue	N-1, Loss of one of the transformers	Lechlade PSS consists of two transformers that are projected to both be constrained under N-1 conditions. Potential options to resolve this constraint are: <ul style="list-style-type: none"> Reinforce the existing transformers at Lechlade PSS, either by adding additional assets or uprating the existing ones. Shift load on the 11kV network over to Black Bourton PSS which is not currently projected to have constraints



ID	Location of proposed intervention	HT Year	EE Year	HE Year	CF Year	Network State	Comments and potential options to resolve the system need
25	Stanton Fitzwarden PSS (New cable triggered by EPV586)	2038 - 2045	2038 - 2045	2038 - 2045	No Issue	N-1, Loss of one of the circuits	Potential options to resolve this constraint are: <ul style="list-style-type: none"> Add an additional cable from Stratton BSP to Stanton Fitzwarden PSS Shift load or adding a new primary in the area, depending on the existing constraints
26	Circuits between Green Road Switching station and Stratton BSP	No Issue	No Issue	No Issue	2038 - 2045	N-1. Loss of the circuit feeding Green Road	Green Road is a switching station which is projected to overload in N-1 conditions for CF. The projected overload likely arises due to increased export from customer-connected distributed generation along that specific section of the network. Due to distance, this substation could likely not be connected to another BSP for load sharing. Due to the fact the switching station is connected directly by one circuit from the BSP options to resolve are: <ul style="list-style-type: none"> Reinforce by upgrading the lines Building a second circuit direct from Stratton BSP to run in parallel.
27	Black Bourton PSS Circuit segment between the transformers up to Stratton BSP	No Issue	No Issue	2038 - 2045	No Issue	N-1, Loss of one of the circuits	Following projected overloading on the transformers ahead of 2035, the 33kV circuit feeding Black Bourton PSS are projected to overload only under HE. Under the HE scenario, rapid growth in electric heating and vehicle charging increases demand on certain feeders. Options to resolve this constraint include: <ul style="list-style-type: none"> Construction an additional primary in the area since other primaries are also projected to have issues Reinforcing the section by uprating the circuit or adding additional lines

Table 8 Summary of system needs identified in this strategy through to 2050 along with indicative solutions.



8.4. Future requirements of the High Voltage and Low Voltage Networks

Our HV/LV spatial plans have shown that there is no clear pattern to future demands on these lower voltage networks. We are therefore planning on a forecast volume basis, and this section provides further context on this work for both the Minety GSP high voltage and low voltage network needs to 2050.

8.4.1. High Voltage Networks

HV Capacity needs

As well as the EHV system needs identified in the previous section, increased penetration of low carbon technologies (LCTs) connecting to the distribution network will result in system needs on the High Voltage (HV) and Low Voltage (LV) networks. To provide a view on the impact of these technologies on the distribution network here we have used the load model that is produced by SSEN's Data and Analytics team.³¹

The load model is a machine learning product which estimates a half-hourly annual demand profile for each household based on a series of demographic, geographic and heating type factors. This enables us to estimate capacity on the electricity network while protecting individual customers data privacy by using modelled data. These views are then aggregated up the network hierarchy based on the combinations of customers associated with each asset. This view is supplemented with the DFES to highlight the projected impact of LCTs on the network.

For all primary substations supplied by Minety GSP, the percentage of secondary substations where projected peak loading exceeds the nameplate rating of the secondary transformer was taken from the load model data. Figure 15 demonstrates how this percentage changes under each DFES scenario from now to 2050.

To satisfy these requirements a variety of solutions will need to be investigated. It is likely that a combination of flexibility and asset replacement will be employed to resolve the projected HV system needs. It is important to note that for HV needs, flexibility is likely to be provided through Distributed Energy Resources (DER), Consumer Energy Resources (CER), and domestic/commercial Demand Side Response (DSR). One of the challenges associated with procuring flexibility to High Voltage and Low Voltage system needs is that only a small number of customers can provide a flexible service due to the requirement to be supplied by a specific secondary transformer. As the role of aggregators develops, we may see a shift in the potential for flexibility in an area. Where the magnitude of an overload is too large for flexibility to be feasible, addition of new assets or asset replacement will be necessary.

³¹ [SSEN Open Data Portal, 2023, SSEN Secondary Transformer – Asset Capacity and Low Carbon Technology Growth.](#)
Minety Grid Supply Point: Strategic Development Plan

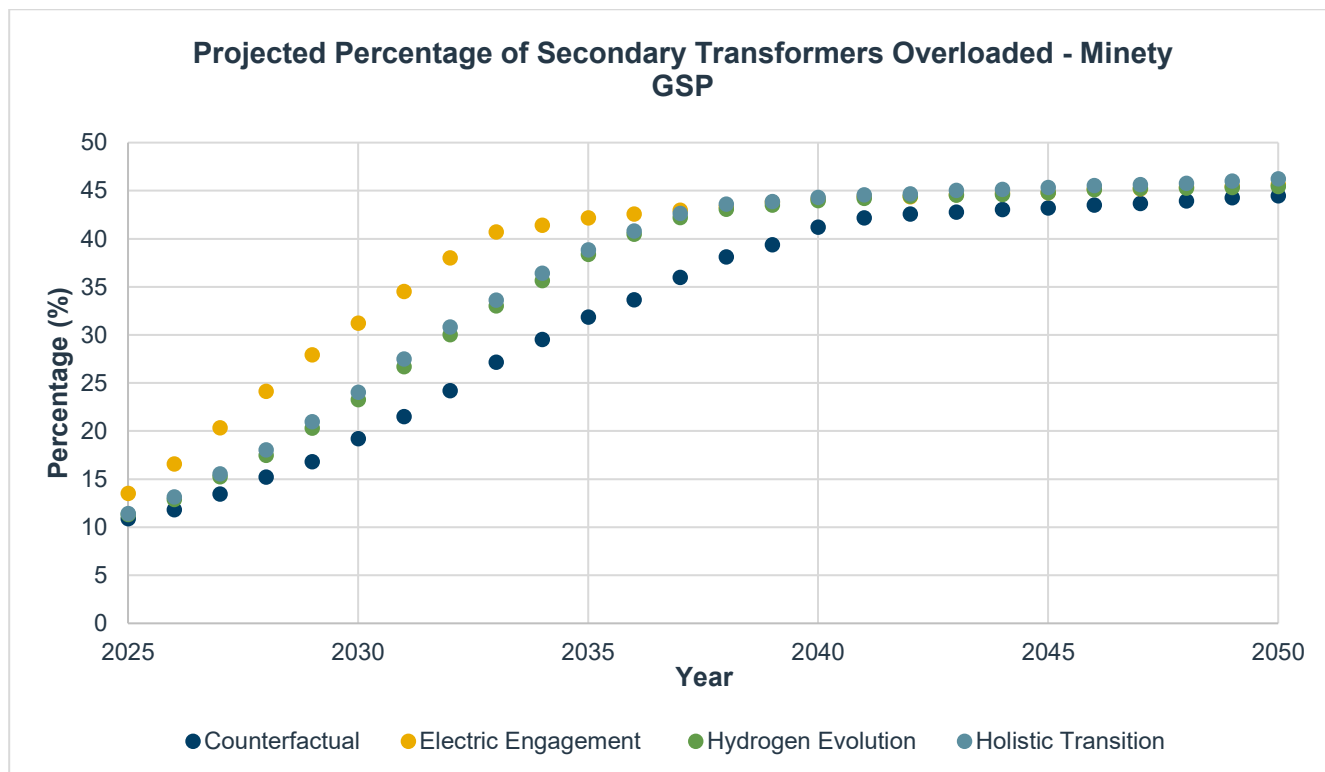

Figure 15 Minety GSP Projected secondary transformer loading. *Source: SSEN Load Model*

Considering the Just Transition in HV development

SSEN are building on the findings from the Vulnerability Future Energy Scenarios (VFES). This innovation project investigated how the use of new foresighting techniques, along with data analytics and expert validation could be used to identify and forecast consumers in vulnerable situations as we move toward net zero. Use of the outputs from the VFES enable SSEN to develop the network in a way that truly accounts for the levels of vulnerability their customers in different locations face.

One of the outputs from this innovation project was the report produced by the Smith Institute.³² This work groups LSOAs³³ that share similar drivers of vulnerability. The groupings were informed by mathematical analysis of demographic data and of SSEN’s priority service register, using machine learning to model the complex relationships that exist between the two. The resulting group numbers and descriptions are shown in Table 9.

Group Number & Level of Vulnerability	Description of Group
1 – Very high	Driven up by higher levels of poor health and disability/mental health benefit claimants, reduced by smaller household sizes.
2 – High	Driven up by larger household sizes, reduced by lower elderly population levels.

32 VFES Machine Learning Discovery of Vulnerability Signatures Report, Smith Institute, 08/11/2022, ([NIA SSEN 0063: VFES – Vulnerability Future Energy Scenarios | SSEN Innovation](#))

33 Lower layer Super Output Areas (LSOAs) ([Statistical geographies - Office for National Statistics](#))
Minety Grid Supply Point: Strategic Development Plan



3 – High	Driven up by larger elderly population levels, reduced by lower levels of disability and mental health benefit claimants.
4 – Slightly higher than average	Driven up by larger elder population levels and moderately higher provision of care, reduced by smaller household sizes.
5 – Slightly lower than average	Driven down by lower elderly population levels and larger levels of ethnic diversity, increased by higher household sizes and greater provision of care.
6 – Low	Driven down by lower level of bad health and disability/mental health benefit claimants, increased by moderate elderly population levels and household sizes.
7 – Very low	Driven down by substantially lower elderly population levels, less provision of care and a higher level of households in private rented dwellings.

Table 9 VFES Groupings

As shown in Table 9, there are several Lower-layer Super Output Areas (LSOAs) that are class 1 meaning they have been identified as very high vulnerability. From using the load model, we can identify secondary transformers that are projected to be over 100% loaded by 2028. Some of these are also identified as being located within the areas classed as highly vulnerable.

These secondary transformers should be prioritised for load related reinforcement as it will reduce the likelihood of asset failure for load reasons and increase network resilience in these areas.

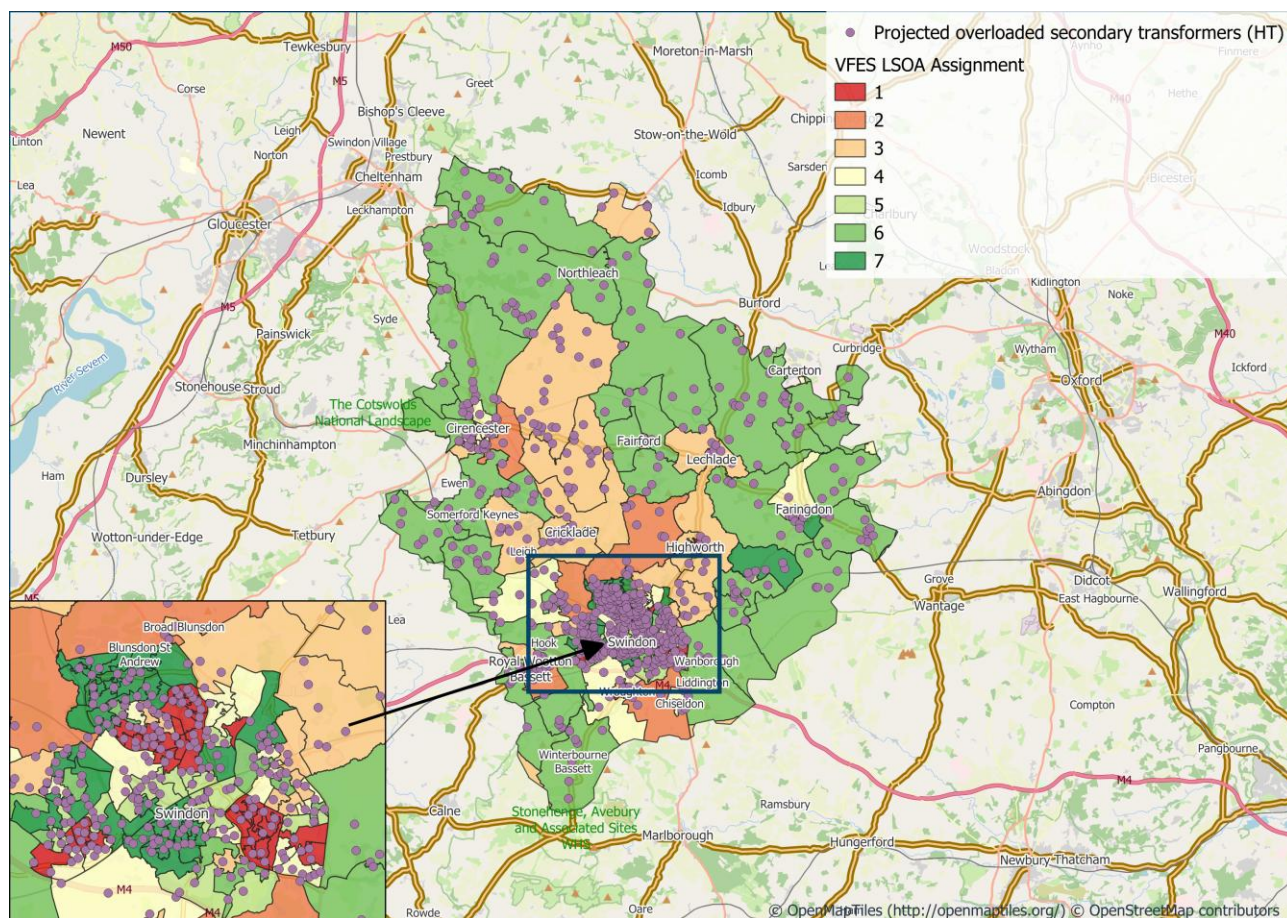

Figure 16 Minety GSP area VFES output with secondary transformer overlay

8.4.2. Low Voltage Networks

Drivers for interventions in low voltage networks may be either capacity related or be driven by voltage requirements. We are progressing options to resolve both of these drivers. From a network perspective the solution typically involves upgrading the number of LV feeders to split/ balance the load and improve voltage or to install another substation at the remote end of the LV network to balance load and improve voltage. In both instances, flexibility at a local level, especially voltage management products linked to battery export and embedded generation such as solar is likely to be required alongside traditional reinforcement.

We are leveraging recent innovation work through Project LEO (Local Energy Oxfordshire) and My Electric Avenue to inform this strategy. Enhanced network visibility through Smart meter data analytics and low-cost substation feeder monitoring is also necessary to enable appropriate dispatch of services and network reconfiguration.

Capacity driven needs – Thermal constraints tend to materialise in the sections of cable leading to the substation (transformer) where multiple customer loads join together. We are modelling requirements out to 2050 leveraging low voltage monitoring and metering equipment combined with analytical techniques. This will demonstrate how the magnitude of the system need of the LV network across Minety changes across scenarios and years out to 2050.

Voltage driven needs – Generally, connection of Low Carbon Technology and large loads such as heat pumps is limited by voltage constraints before thermal constraints when located more than around 150m from the local



secondary transformer. Increased loading on our low voltage networks can reduce the voltages to consumer premises. This is a non-linear relationship and as such requires more complex analysis. We are currently undertaking analysis to better understand the extent of this future need.

Initial analysis indicates that 31.65% of low voltage feeders may need intervention by 2035 and 48.38% by 2050 under the HT scenario as shown in Figure 17. The need is unlikely to be triggered until 2028 onwards. However, due to the timeline to grow workforce, with jointing skills taking typically 4 years to be fully competent, it is necessary to start recruitment and initiate programmes ahead of need to be able to deliver the required volumes from 2028 onwards.

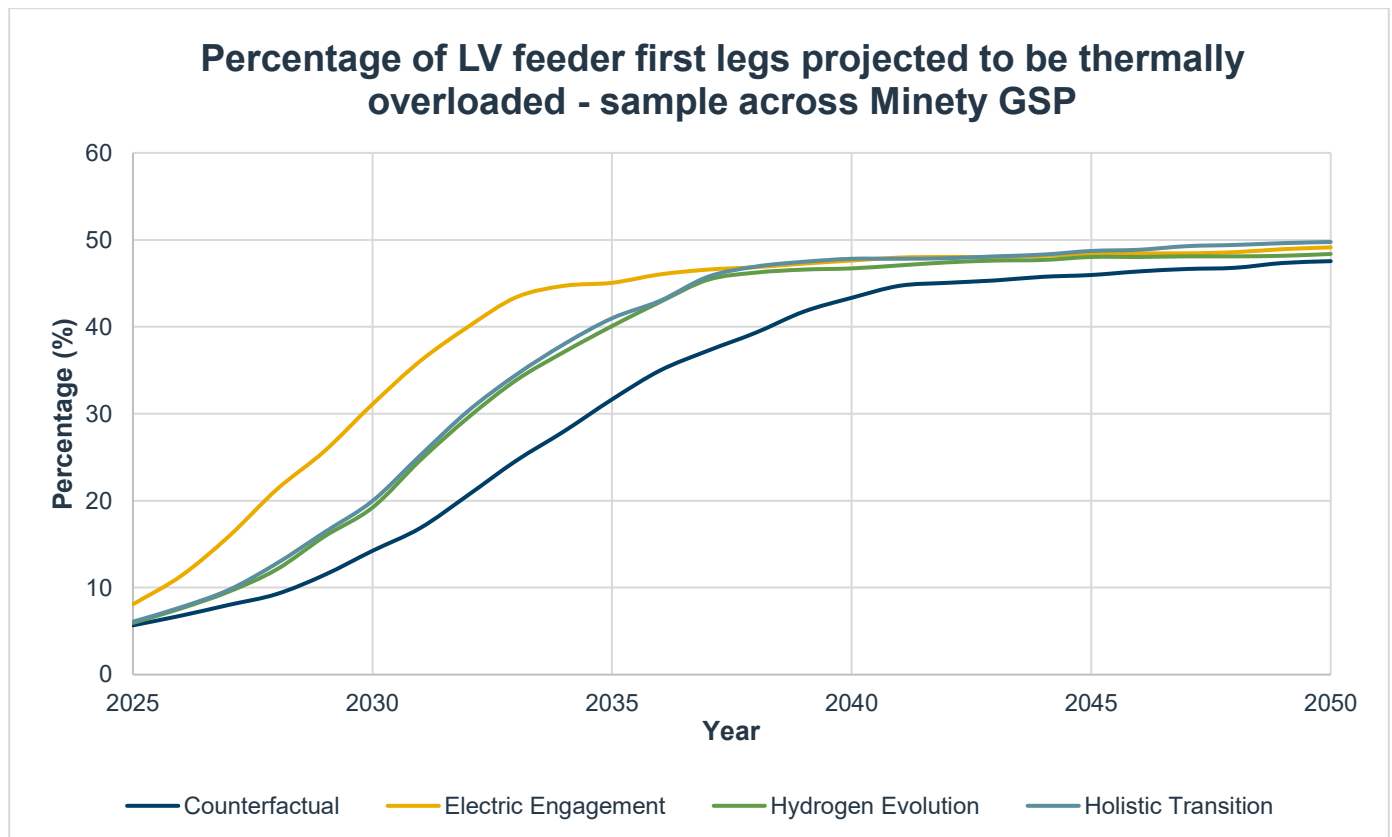

Figure 17 Percentage of LV feeders projected to be overloaded under Minety GSP



9. RECOMMENDATIONS

The review of stakeholder engagement and the SSEN 2024 DFES analysis provides a robust evidence base for load growth across Minety GSP group in both the near and longer term. Drivers for load growth across Minety GSP arise from multiple sectors and technologies. These drivers impact not only the EHV network but will drive system needs across all voltage levels.

Across the Minety GSP supply area, work has already been triggered through the DNOA process and published in DNOA Outcomes Reports. This delivers a significant amount of additional capacity in the area over the next decade. These are driven by customer connections and system needs that will arise this decade but are being developed to meet 2050 needs.

The findings from this report have provided evidence for 5 key recommendations:

1. System needs that have been identified at earlier timescales (ahead of 2035) should be studied in more detail and these should be progressed through the DNOA process. This relates to the assets tabulated in section 8.2.
2. There are a significant number of secondary transformers due to be overloaded by 2030 and by 2050. These are primarily concentrated around the northern Swindon area– further investigation into these requirements as well as possible efficient solutions is recommended to ensure capacity of the HV/LV network.
3. Industrial decarbonisation across the Minety GSP will increase the electricity demand out to 2050. Continued engagement with the data centres, large retail parks and DigiTech companies are needed to gain a better understanding on the load that will be required and when it will be needed.
4. Minety GSP had a high penetration of DER assets, which impose stress on transformers, voltage regulation devices (such as on-load tap changers), and switchgear, potentially reducing asset life. To maintain system stability and asset health, future planning should incorporate voltage monitoring and analysis more systematically. This will support better voltage control, improve protection performance, and inform investment decisions in monitoring, control, and grid reinforcement.
5. Furthermore, considering the significant growth in DERs expected across Minety GSP supply area, engagement with NGET and NESO should be proactive creating a long-term plan for the area which incorporates the outputs of CP2030 and connections reform.

Actioning these recommendations will allow SSEN to develop a network that supports local net zero ambitions. By doing so, contributing to net zero targets at a national level.



Appendix A Existing network schematics (33kV network)

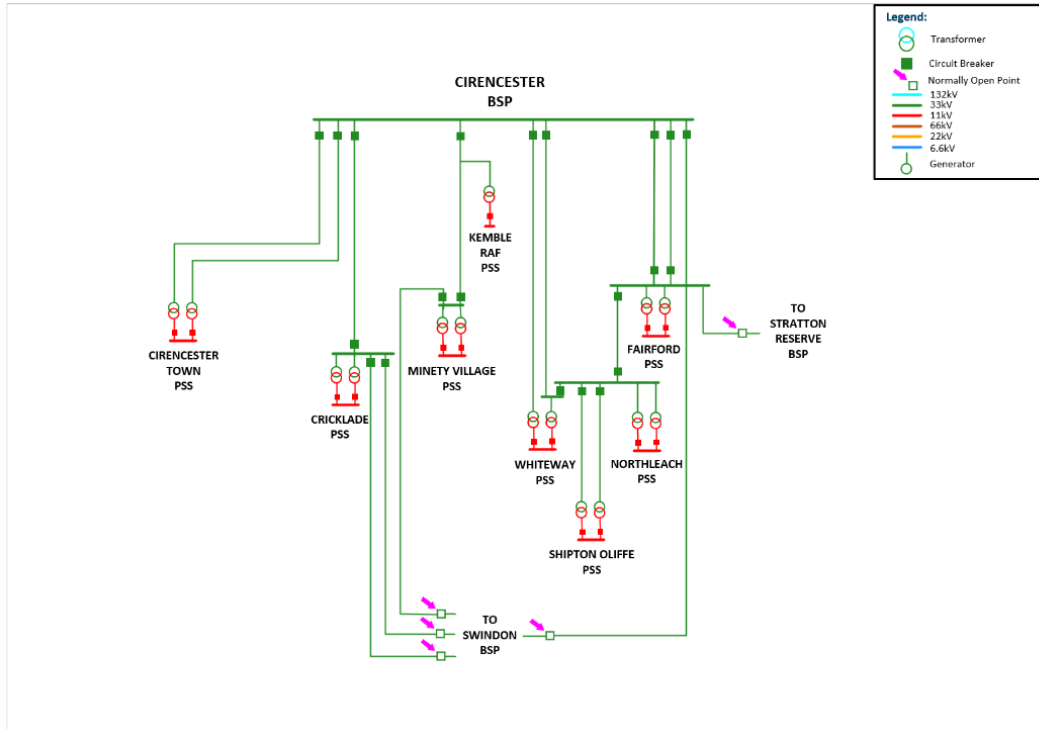

Figure 18 Cirencester BSP – Existing network schematic.

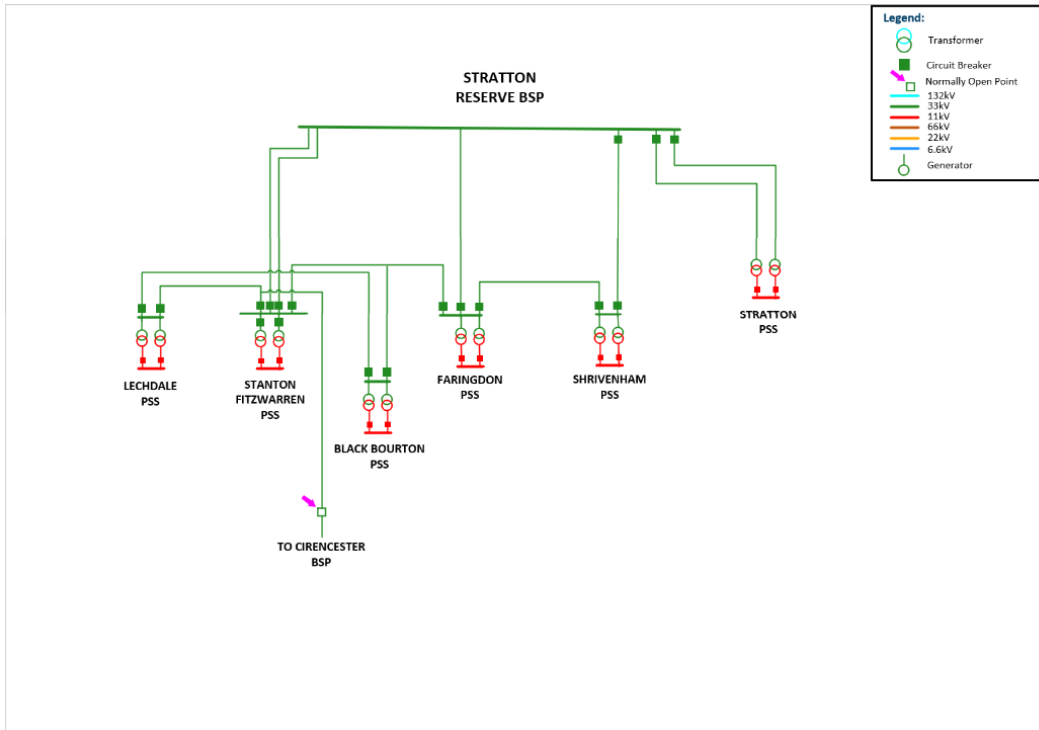

Figure 19 Stratton Reserve BSP – Existing network schematic.

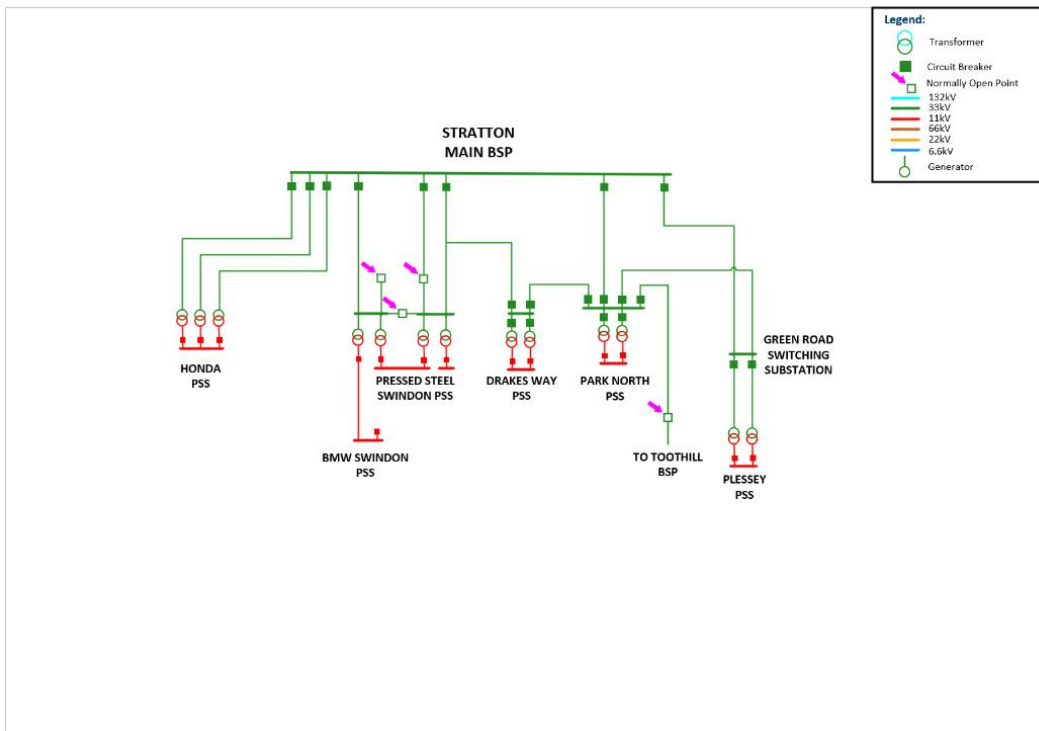

Figure 20 Stratton Main BSP – Existing network schematic.

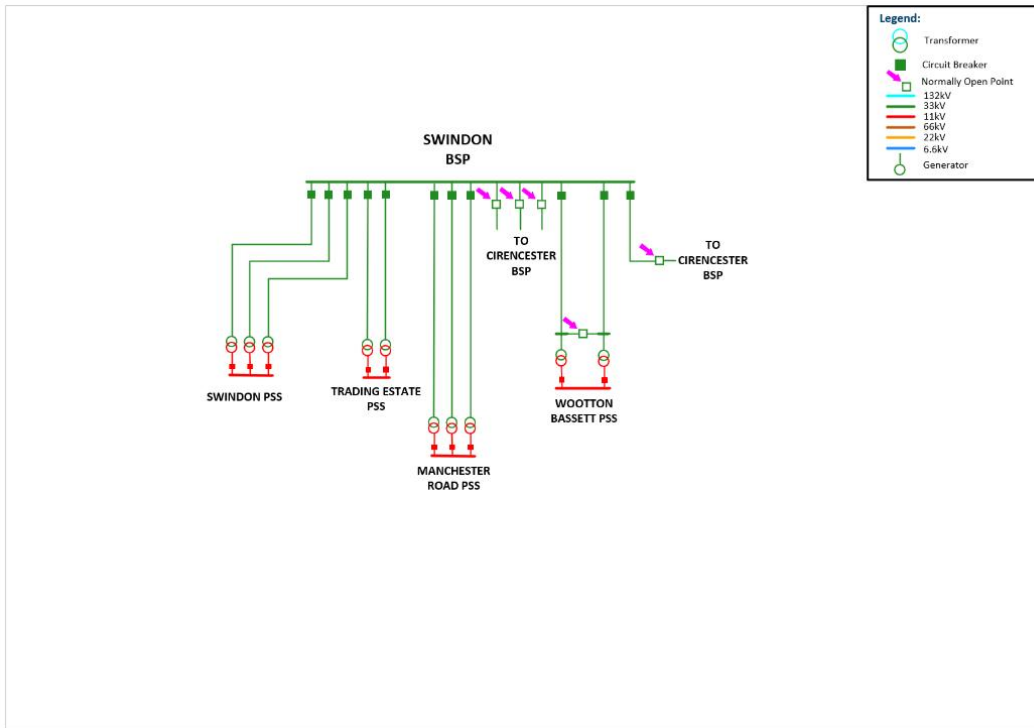

Figure 21 Swindon BSP – Existing network schematic.

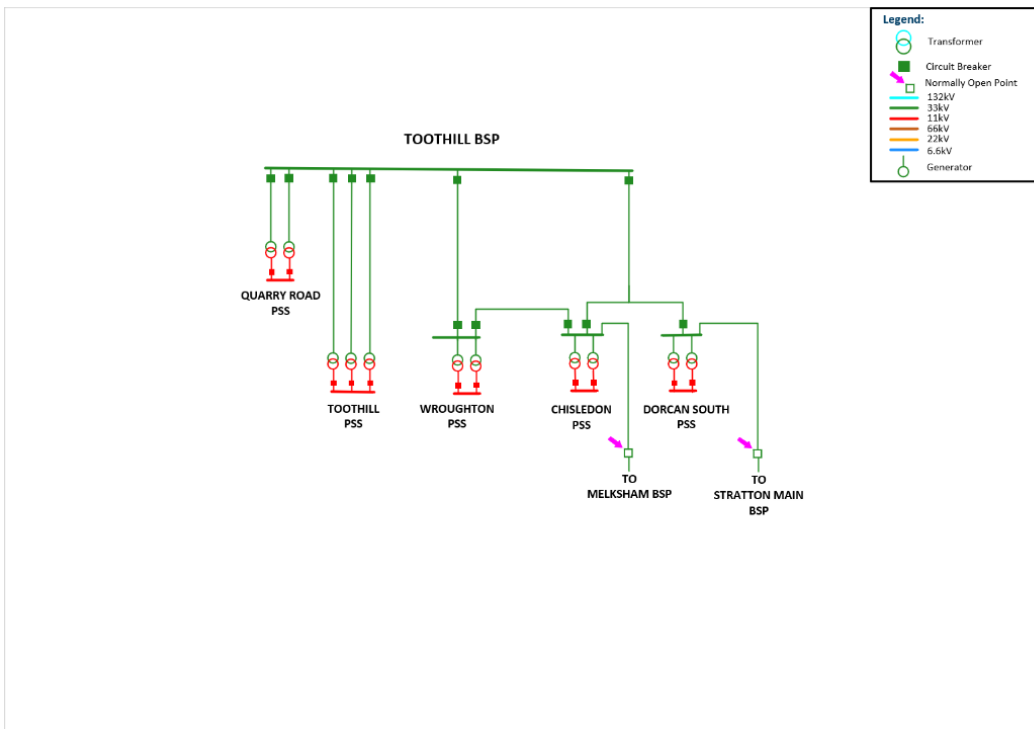

Figure 22 Toothill BSP – Existing network schematic.



Appendix B Future network schematics following completion of triggered works (33kV network)

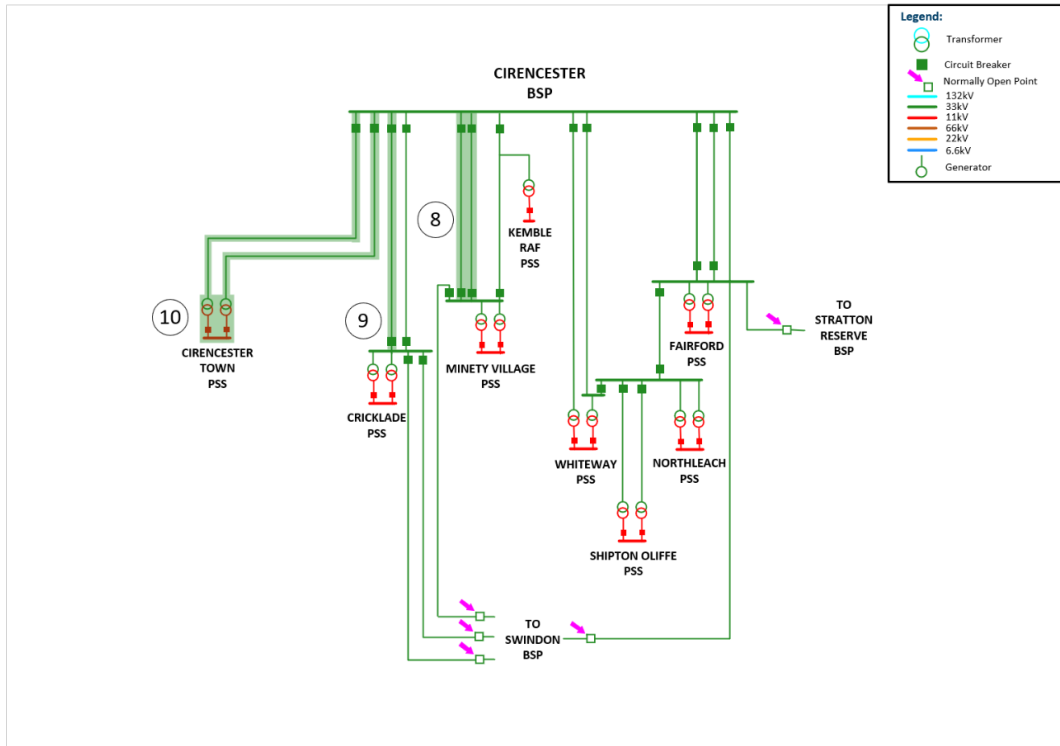

Figure 23 Cirencester BSP – Following the completion of triggered works.

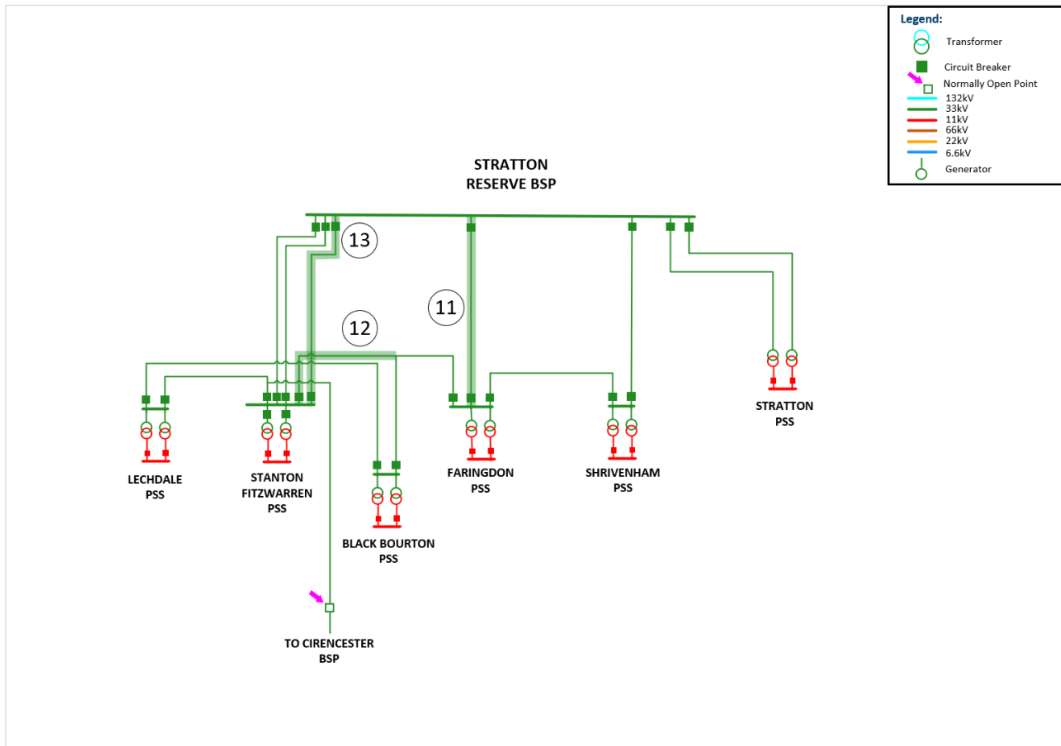

Figure 24 Stratton Reserve BSP - Following the completion of triggered works.

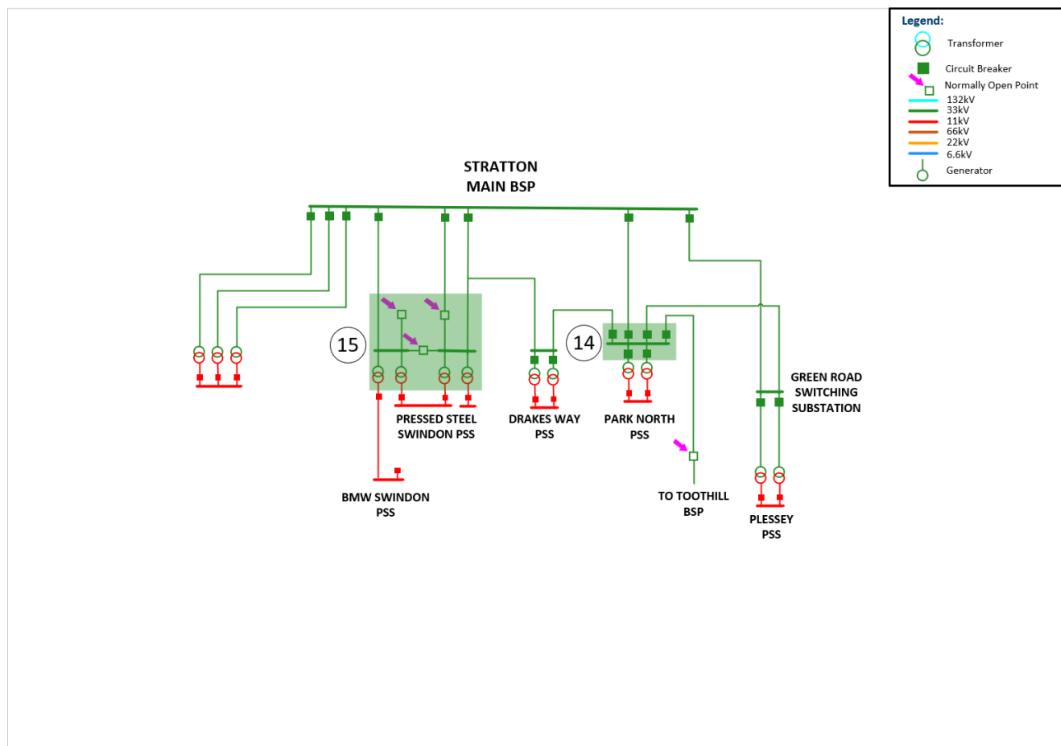

Figure 25 Stratton Main BSP - Following the completion of triggered works.

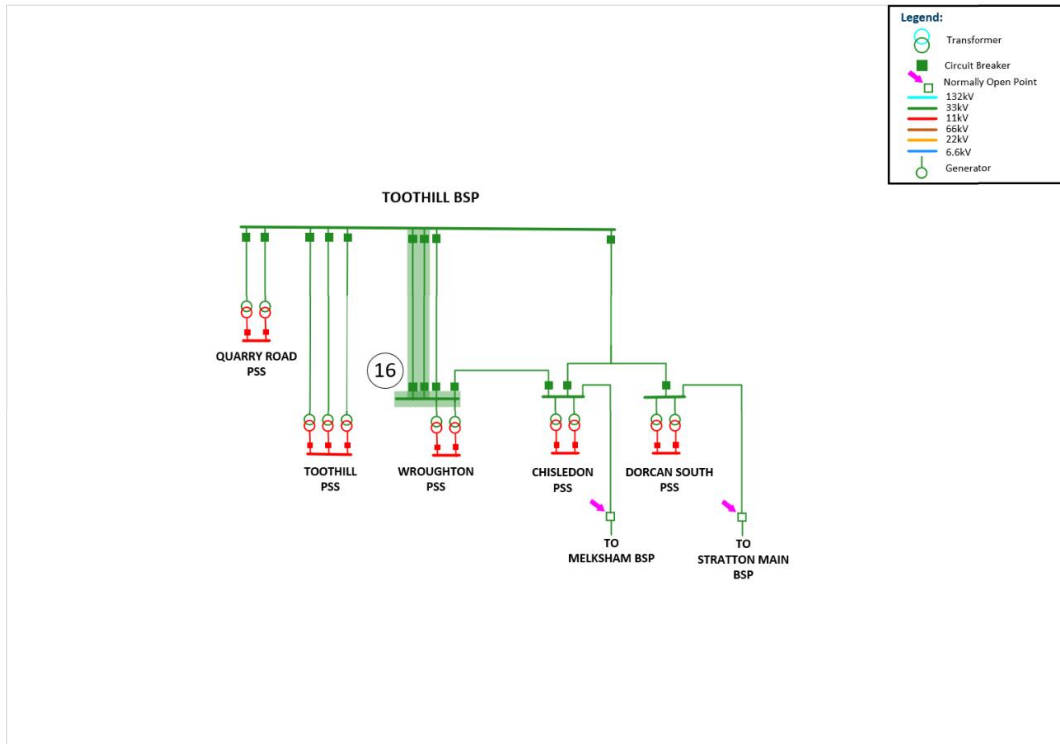

Figure 26 Swindon BSP - Following the completion of triggered works.



Appendix C EHV/HV spatial plans for other DFES scenarios

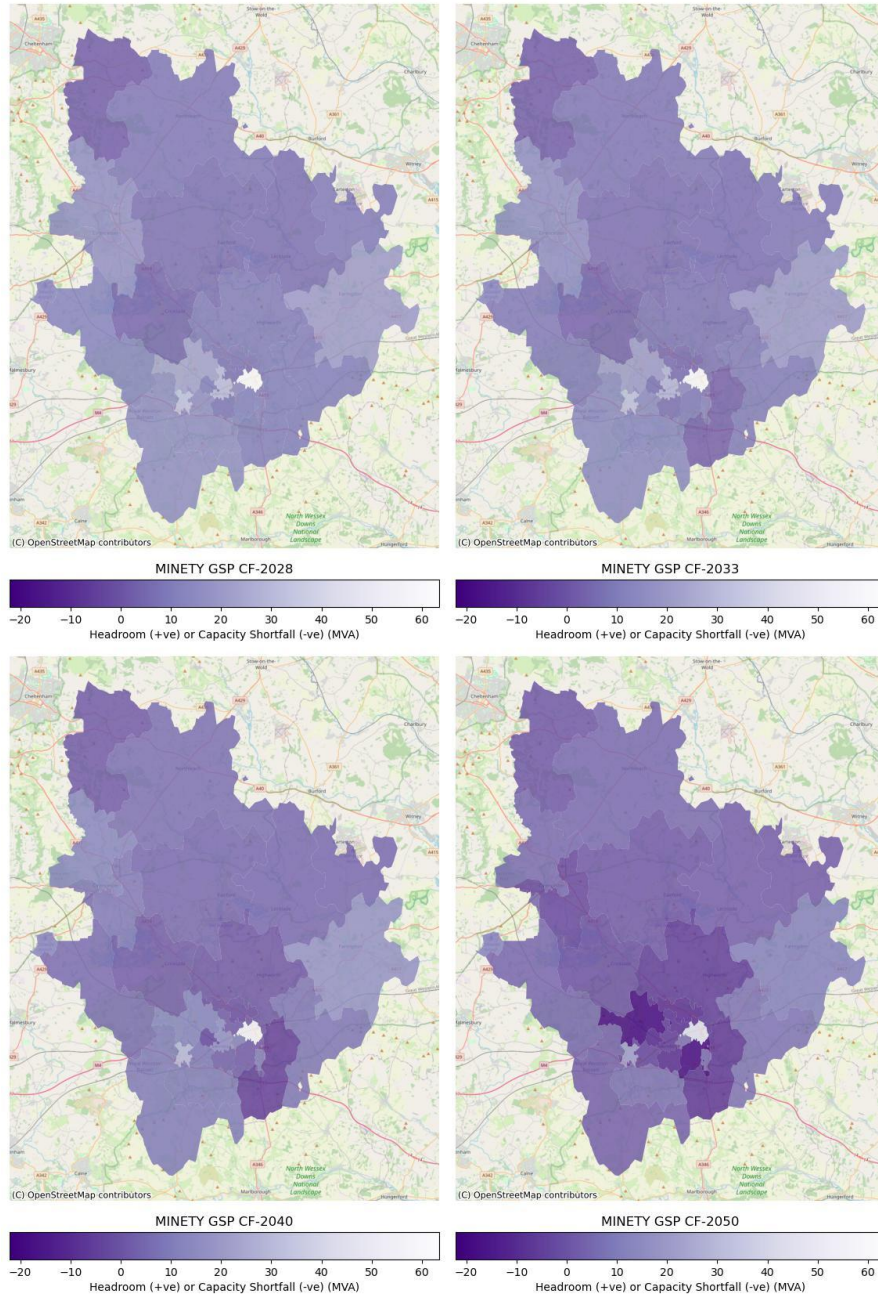

Figure 27 Minety GSP - EHV/HV Spatial Plan - Counterfactual

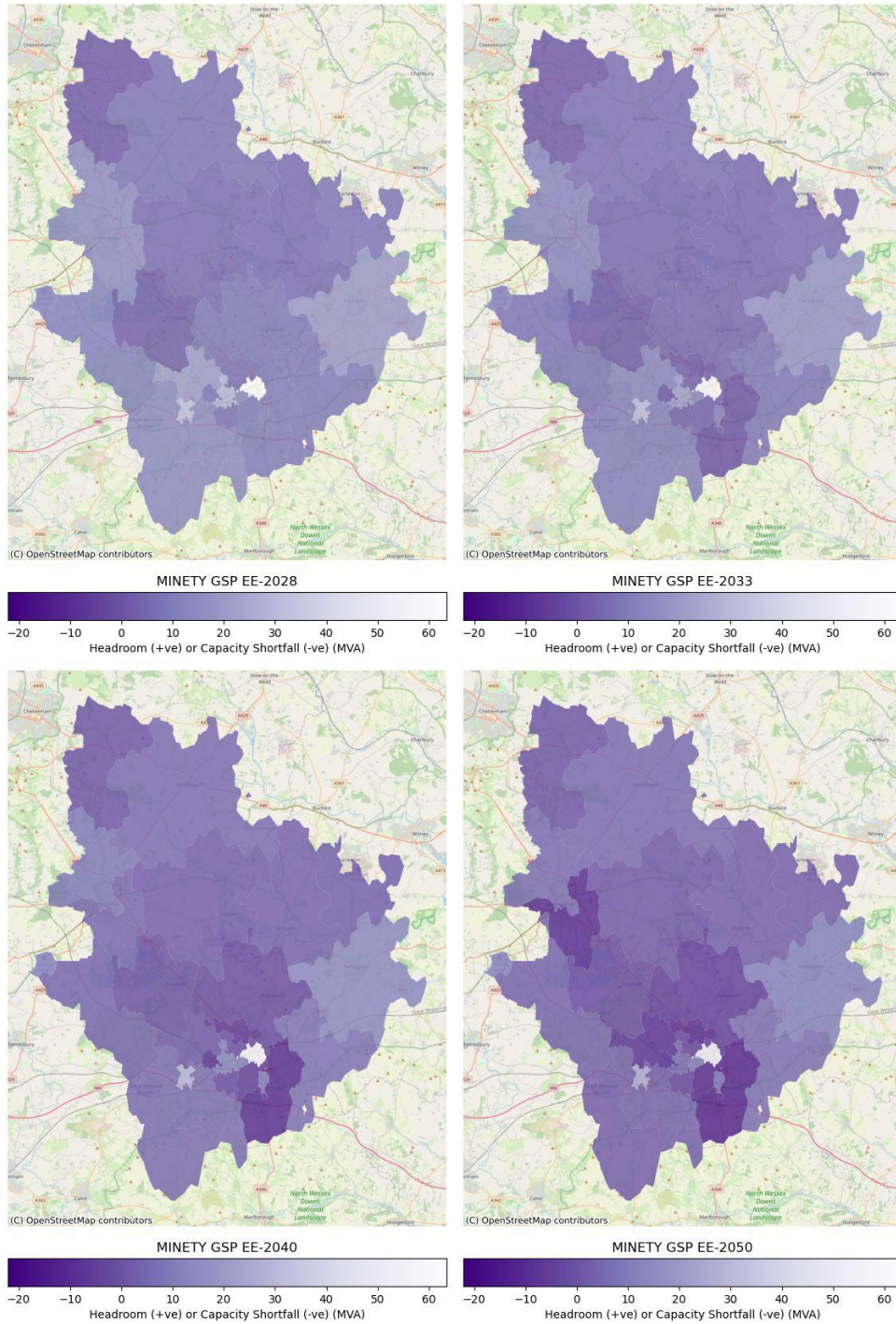

Figure 28 Minety GSP - EHV/HV Spatial Plan – Electric Engagement

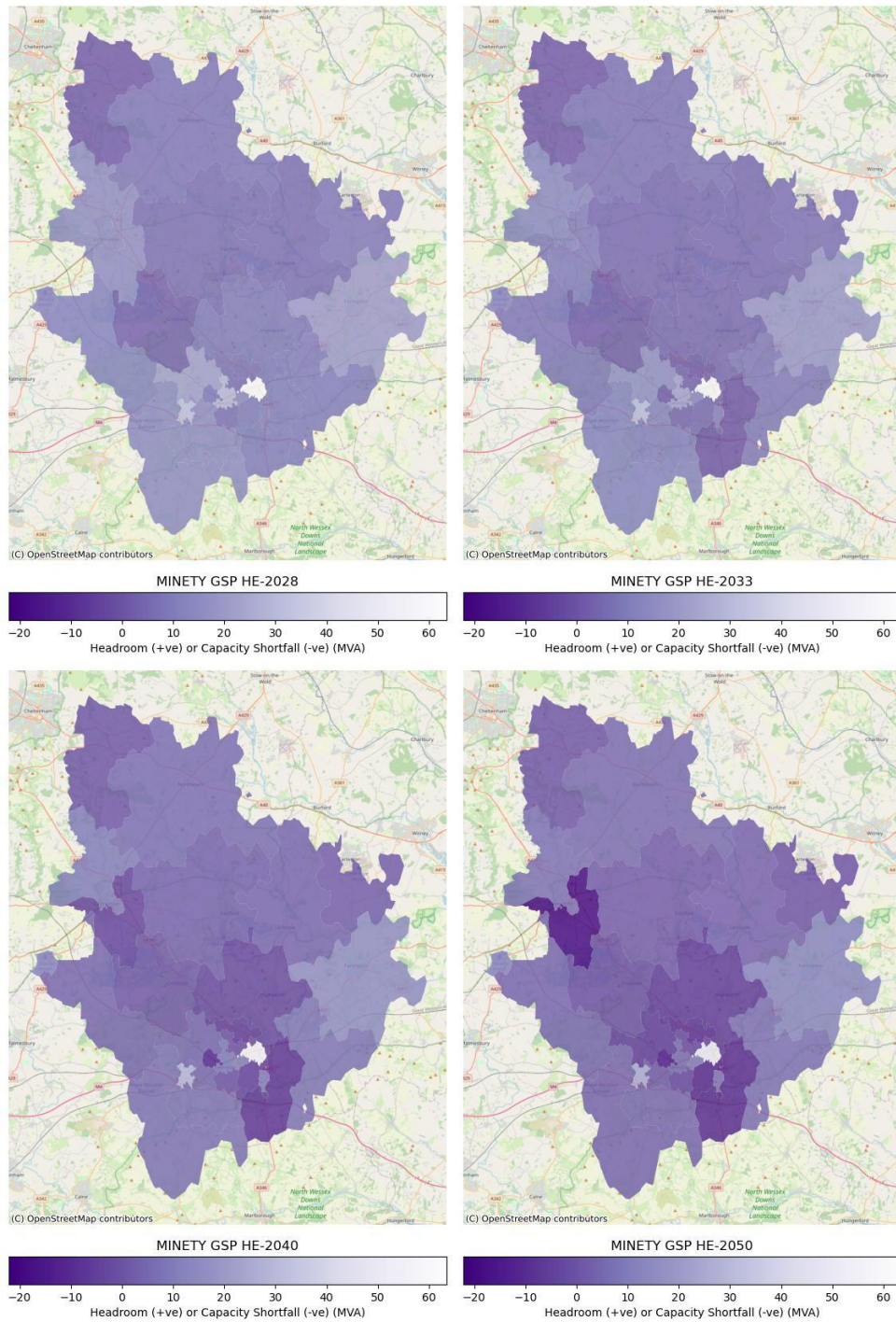

Figure 29 Minety GSP - EHV/HV Spatial Plan – Hydrogen Evolution



Appendix D HV/LV spatial plans for other DFES scenarios

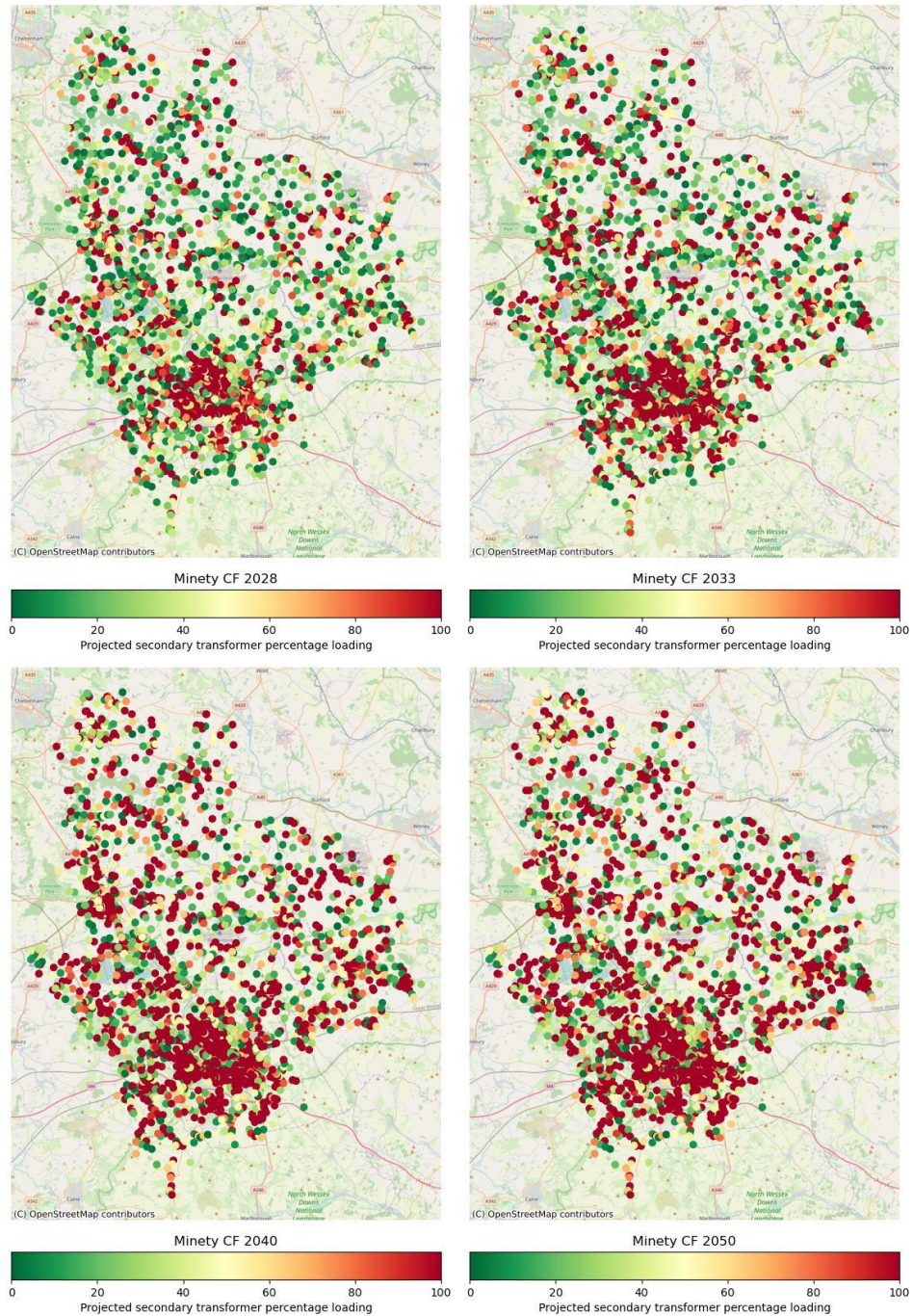

Figure 30 Minety GSP - HV/LV Spatial Plan - Counterfactual

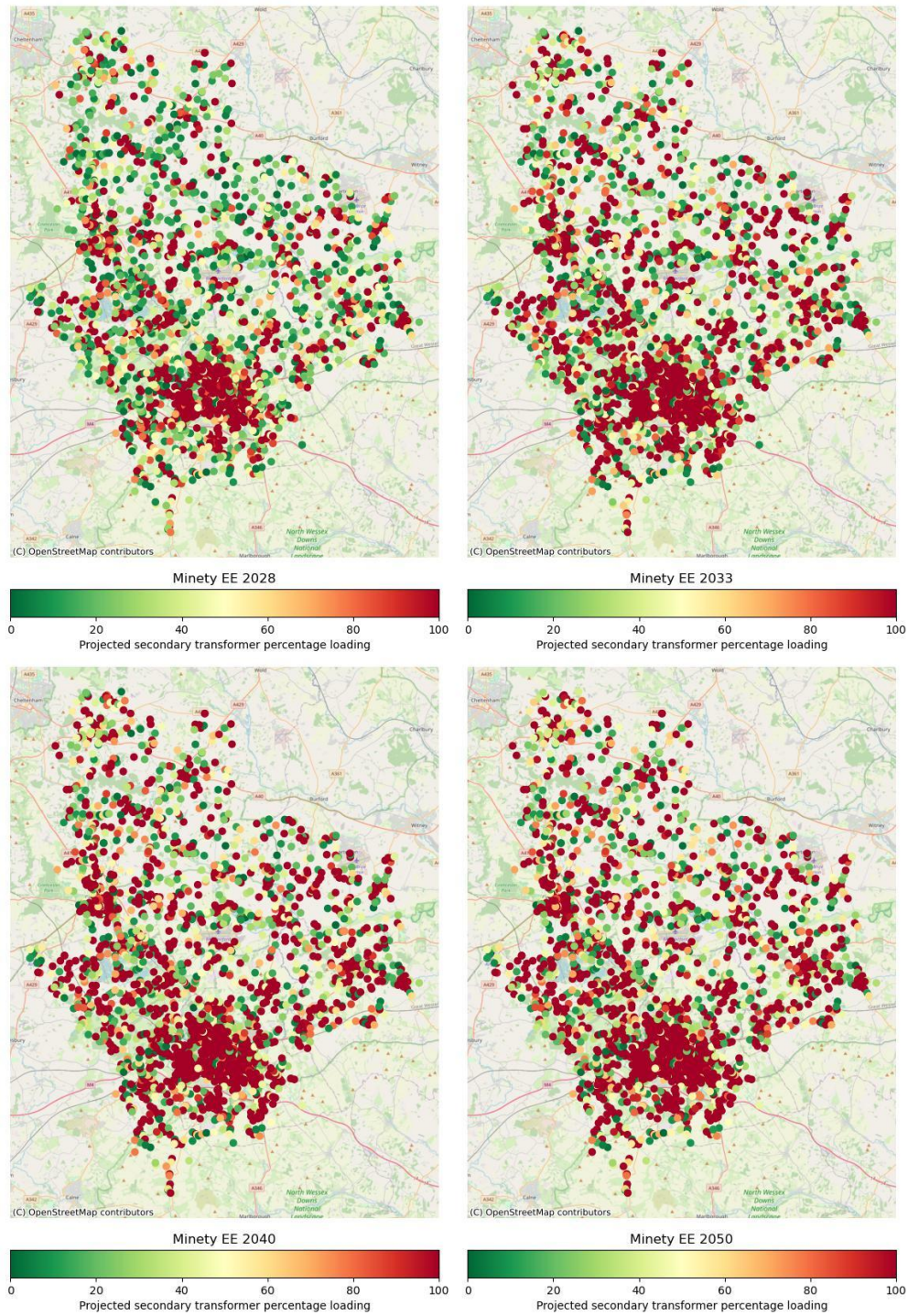

Figure 31 Minety GSP - HV/LV Spatial Plan – Electric Engagement

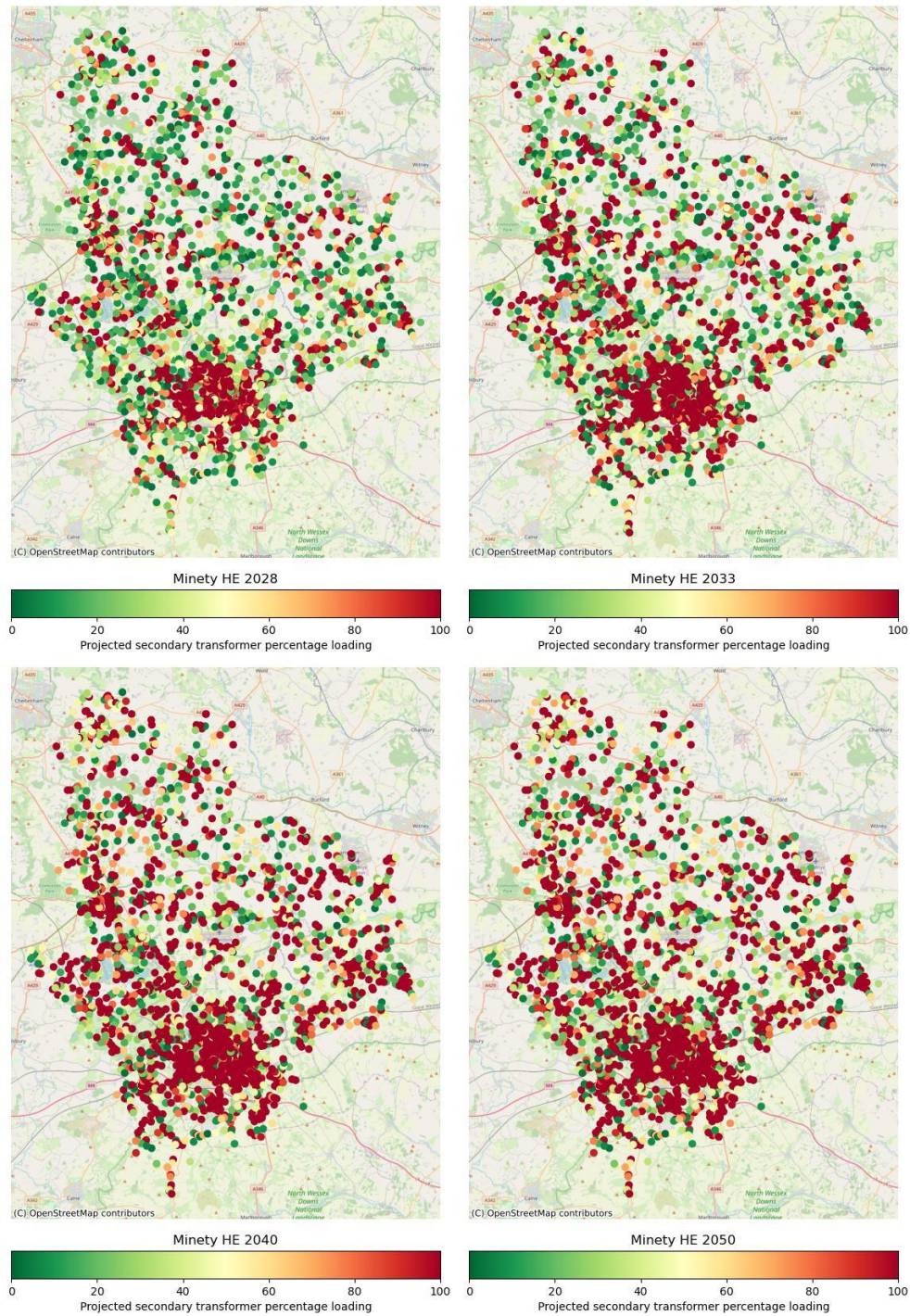

Figure 32 Minity GSP - HV/LV Spatial Plan – Hydrogen Evolution



Appendix E Relevant DNOA Outcome Reports



DNOA Outcome Report

Faringdon (Shrivenham, Faringdon, Black Bourton PSSs)

Scheme description

- The reinforcement of the Stratton 33kV circuits will increase capacity in the northeast of Swindon area. Postcode(s): GL7, OX18, SN4, SN6, SN7.
- Local authority: Vale of White Horse, West Oxfordshire, Swindon
- Load related – circuit thermal overload and voltage issue during FCO conditions due to forecasted demand growth.

Proposed option

- Smart/Asset Solution: Installation of additional 33kV circuit between Stratton BSP and Faringdon PSS.
- Flexibility was unable to be utilised due to insufficient flexible assets.
- This option addresses the forecasted thermal overload of the Stratton circuits out to 2035.
- Capacity released: 14MVA

System need requirement

J	F	M	A	M	J	J	A	S	O	N	D

DNOA History

2024/25	2025/26	2026/27	2027/28	2028/29
Initial assessment				

Indicative flexibility price (if available):

- Availability price: N/A
- Utilisation price: N/A

Reinforcement timeline

- Reinforcement delivery by the end of 2026/27.

Estimated peak MW outside firm network capacity under each scenario
Grey text relates to estimated peak MW without reinforcement delivery

	2024/25	2025/26	2026/27	2027/28	2028/29	2029/30	2030/31
CT	4.7	5.3	6.0	- (6.8)	- (7.7)	- (8.7)	- (9.8)
ST	4.1	4.4	4.9	- (5.5)	- (5.9)	- (6.5)	- (7.0)
LTW	5.4	6.2	7.1	- (8.1)	- (8.8)	- (10.0)	- (11.3)
FS	4	4.2	4.6	- (5.1)	- (5.3)	- (5.8)	- (6.2)

Constraint management timeline

23 | Scottish and Southern Electricity Networks Distribution | DNOA Outcomes Report November 2024 – Ref. 1124-15

Minety Grid Supply Point: Strategic Development Plan

56



DNOA Outcome Report



Faringdon (Faringdon PSS)

Scheme description

- The reinforcement of the Faringdon PSS will increase capacity in the Faringdon area. Postcode(s): OX11, OX12, OX14, OX18, OX3, OX7, PO2, RG2, RG20, SN6, SN7, SN15, SO17, TW14.
- Local Authority: Vale of White Horse.
- Load related – substation and circuit overload during FCO conditions due to forecasted demand growth.

Proposed option

- Asset Solution: Reinforcement of 2 x 33/11kV transformers.
- Flexibility was unable to be utilised due to there being insufficient flexible assets.
- This option addresses the forecasted demand at Faringdon PSS out to 2035.
- Capacity released: 14MVA.

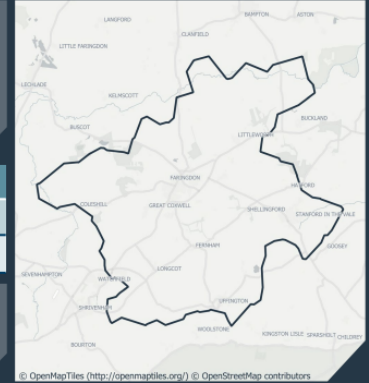

System need requirement

J	F	M	A	M	J	J	A	S	O	N	D

DNOA History

2024/25	2025/26	2026/27	2027/28	2028/29
Initial assessment				

Indicative flexibility price (if available):

- Availability price: N/A
- Utilisation price: N/A

Reinforcement timeline

- Reinforcement delivery by the end of 2026/27.

Estimated peak MW outside firm network capacity under each scenario

Grey text relates to estimated peak MW without reinforcement delivery

	2024/25	2025/26	2026/27	2027/28	2028/29	2029/30	2030/31
CT	5.1	5.4	5.8	- (6.3)	- (6.8)	- (7.3)	- (7.9)
ST	4.7	4.9	5.2	- (5.5)	- (5.7)	- (6.1)	- (6.3)
LTW	5.5	5.9	6.4	- (7.0)	- (7.4)	- (8.1)	- (8.7)
FS	4.7	4.8	5.0	- (5.3)	- (5.4)	- (5.7)	- (5.9)

Constraint management timeline

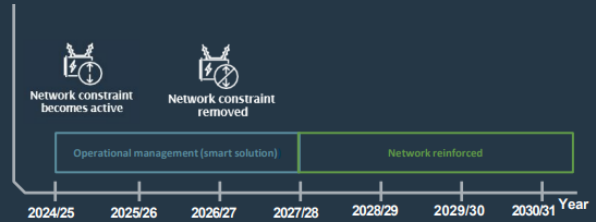



Cricklade - Minety (Cricklade PSS & Minety Village PSS)

DNOA outcome: Asset solution

Scheme description

- The reinforcement of the circuits from Cirencester BSP to Cricklade PSS, and to Minety Village PSS and Kemble RAF PSS will increase capacity in the Cricklade-Minety area. Postcode(s): GL7, SN4, SN5, SN6, SN16.
- Local authority: Cotswold and Wiltshire
- Load related – Circuit voltage issues during FCO conditions due to forecasted demand growth.

Proposed option

- Asset Solution: An additional circuit from Cirencester BSP to Cricklade PSS, two additional circuits from Cirencester BSP to Minety Village PSS, and reconfigure the existing ringed network.
- Flexibility was unable to be utilised due to it not being suitable for the constraint type.
- This option addresses the forecasted issues out to 2050.
- Capacity released: 73.3 MVA

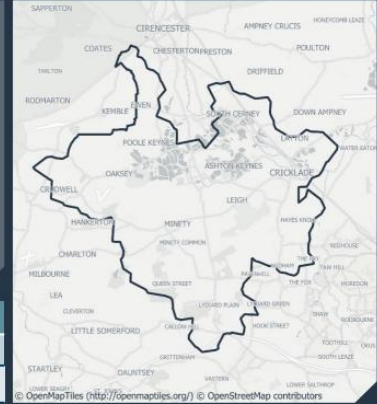

Indicative flexibility price (if available)

Availability price: £ N/A /MWh Utilisation price : £ N/A /MWh

System need requirement

J	F	M	A	M	J	J	A	S	O	N	D

DNOA History

2024/25	2025/26	2026/27	2027/28	2028/29
Initial assessment				

Estimated peak MW outside firm network capacity under each scenario

	25/26	26/27	27/28	28/29	29/30	30/31	31/32	32/33	33/34	34/35
CT	-	-	-	-	-	-	-	-	-	-
ST	-	-	-	-	-	-	-	-	-	-
LTW	-	-	-	-	-	-	-	-	-	-
FS	-	-	-	-	-	-	-	-	-	-

Constraint management timeline





Appendix F Glossary

Acronym	Definition
AIS	Air Insulated Switchgear
ANM	Active Network Management
BAU	Business as Usual
BSP	Bulk Supply Point
CB	Circuit Breaker
CBA	Cost Benefit Analysis
CER	Consumer Energy Resources
CF	Counterfactual
CMZ	Constraint Managed Zone
CT	Consumer Transformation
DER	Distributed Energy Resources
DESNZ	Department for Energy Security and Net Zero
DFES	Distribution Future Energy Scenarios
DNO	Distribution Network Operator
DNOA	Distribution Network Options Assessment
DSO	Distribution System Operation
DSR	Demand Side Response
EE	Electric Engagement
EHV	Extra High Voltage
EJP	Engineering Justification Paper
ER P2	Engineering Recommendation P2
NESO	National Energy System Operator
NGET	National Grid Electricity Transmission
ENA	Electricity Networks Association
EV	Electric Vehicle



FES	Future Energy Scenarios
FS	Falling Short
GIS	Gas Insulated Switchgear
GSPs	Grid Supply Point
HE	Hydrogen Evolution
HT	Holistic Transition
HV	High Voltage
kV	Kilovolt
LAEP	Local Area Energy Planning
LCT	Low Carbon Technology
LENZA	Local Energy Net Zero Accelerator
LV	Low Voltage
LW	Leading the Way
OHL	Overhead Line
PSS	Primary Substation
PV	Photovoltaic
NSHR	Network Scenario Headroom Report (part of the Network Development Plan)
MW	Megawatt
MVA	Mega Volt Ampere
ODM	Operational Decision Making
RESOP	Regional Energy System Operation Planning
RIIO-ED1/2	Revenue = Incentives + Innovation + Outputs, Electricity Distribution 1 / 2 (regulatory price control periods)
SDP	Strategic Development Plan
SEPD	Southern Electric Power Distribution
SLC	Standard Licence Condition
SSEN	Scottish and Southern Electricity Network
ST	System Transformation



UM	Uncertainty mechanism
VFES	Vulnerability Future Energy Scenarios
WSC	Worst Served Customers

Appendix G Appendix H: Summary of consultation feedback

Following the consultation for this document, several changes have been made to the document to reflect the feedback received from our stakeholders. Feedback from other SDPs which also applies to Minety SDP has also been taken into account.

A summary of the changes made based on the Minety SDP consultation is tabulated below; in some cases multiple actions have been taken.

Feedback theme	Action taken	Section (page number)
Updated to reflect OCC strategies (Mobility Hubs, Rail, EVIS) and to align the narrative with DFES submissions.	Additional detail added to the council overview.	Section 3.1.1
Incorporate updated Cotswold District Council climate-emergency and net-zero housing/transport policies	Additional detail added to the council overview.	Section 3.1.1



CONTACT

whole.system.distribution@ese.com



Scottish & Southern
Electricity Networks